

Operation Manual

TRIPLE SPIN



Family Fun Companies, INC.
Parts, Service and Distribution
708-598-3720



Operation Manual

Before using the product, be sure to read the following:

To maintain the safety:

To ensure safe usage of this product, be sure to read the entire manual. The following instructions are intended for users, operators and the personnel in charge of the operation of the product.

Explanations which require special attention are listed below.



WARNING

Disregarding this text could result in serious injury.



Caution

Disregarding this text could result in damage to the machine.



Notice

An advisory text to hint or help understanding.



Operation Manual

1. The company

Thank you for purchasing the Family Fun Companies, Triple Spin. Our company was found in 1993 to develop unique and high quality games for the entertainment industry. Quality, Service and Customers are our primary focus.

INTRODUCTION OF THE MANUAL

This owner's Manual is intended to provide detailed descriptions together with all the necessary information covering the general operation of electronic assemblies, servicing control, spare parts, etc. as regards the product.

This manual is intended for the owner, personnel and managers in charge of operation of the product. Operate the product after carefully reading and sufficiently understanding the instructions. If the product fails to function satisfactorily, non-technical personnel should no circumstances touch the internal system.

DEFINITION OF LOCATION'S MAINTENANCE MAN AND SERVICEMAN



WARNING

Non-technical personnel who do not have technical knowledge and expertise should refrain from performing such work that this manual requires the location's maintenance man or a serviceman to carry out, or work which is not explained in this manual. Failing to comply with this instruction can cause a severe accident such as electric shock.

Ensure that parts replacement, servicing & inspections, and troubleshooting are performed by the locations maintenance man or the serviceman. It is instructed herein that particularly hazardous work should be performed by the serviceman who has technical expertise and knowledge.



Operation Manual

2. Specifications



Specifications

- 1 Rated power supply:** AC110V 50/60Hz
- 2 Power Consumption:** Min power consumption 180W
Max power consumption 580W
- 3 Dimensions:** 660X920X2323(mm)
- 4 Weight:** **About** 125 Kg
- 5 Environment Condition:** Temperature(indoor):-10℃~+40℃
Humidity: ≤90%
Atmospheric pressure:86Pa~106Pa

Note: Game parameters are subject change without notice.

3. Package contents

3.1 Body Assembly: 1 unit









- Make sure that all the parts shown below are included in product package.

- If any parts are missing, contact your distributor.



Operation Manual

3.2 Accessories

NO.	Component	Specification	Q'ty	Illustration
1	Power wire	10A/250V 1.8m	1	
2	Fuse	3A/250V Φ5-20MM	1	
3		10A/125V Φ5-20MM		
4	Operation	中文/ENGLISH	1	
5	Key	171	2	
		2222	2	
6	Sensor	GPS009B1	1	
7	Bulb	24V5W E12	10	
8	Allen Wrench	CR-V 3mm	1	
9	Screw	Φ5*16	3	



Operation Manual

4. Installation

Do Not install machine on sloped surfaces

The installation of Marquis

1. Install three screws into marquis
2. Install three screws into body

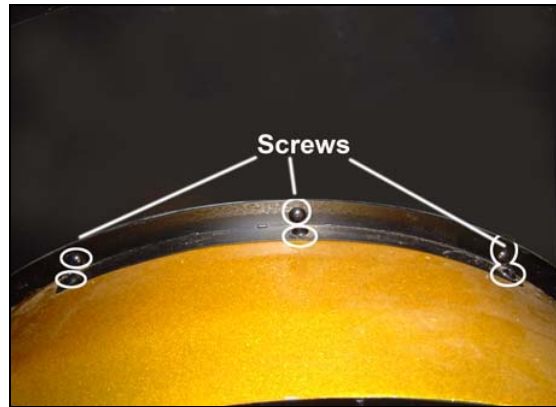

Game leveling

Install this machine on a flat surface. Adjust levelers to lift casters off the ground and level game.

Make sure that the machine is level with the floor. If the machine is not level medals may not be play well.

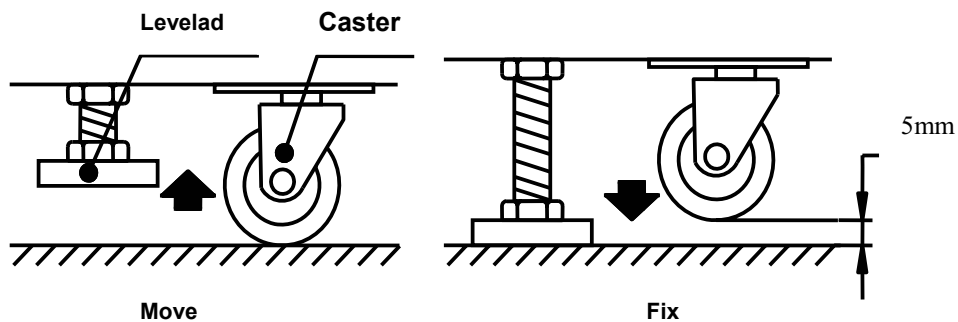

5. Connecting the power cord and grounding



Operation Manual

The connection:

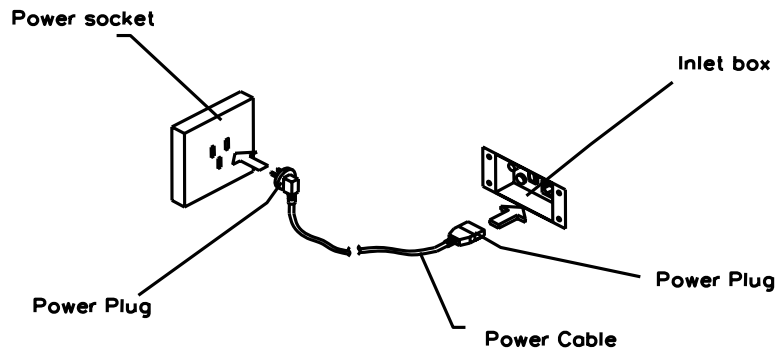

WARNING

Be sure to connect the ground wire before turn on the machine. Failure to connect the ground wire could result in electric shock if power occurs.

Warning:

- ★ Do not put heavy items on power cord.

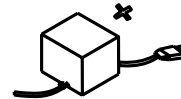

- ★ Do not touch the power plug with a wet hand.

- ★ Do not draw or twist the cord.

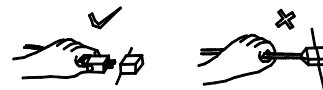

- ★ Do not place the cord near a heat source.

- ★ Run this machine with the correct power configuration.





Operation Manual

6. Game description

How to play

Game play begins when the player inserts enough money into the game to create 1 credit. (If the player inserts multiple coins the game will hold the credits)

Stop the bottom two wheels on "Next" and the top wheel on "Bonus" to win the Jackpot.

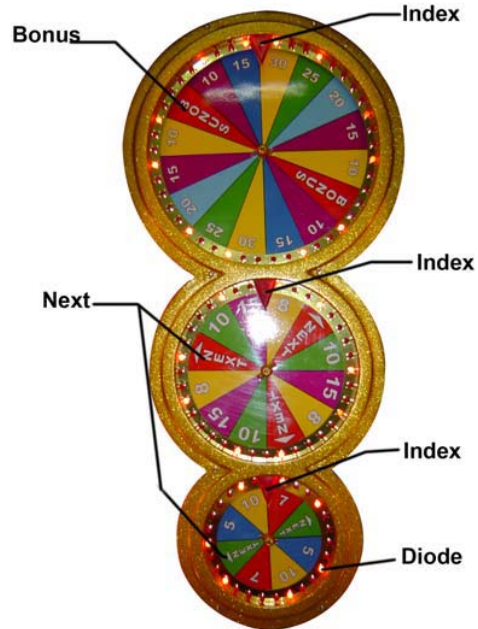



Operation Manual

7. Switches

The DIP BANK SW1, BANK SW2 and BANK SW3 Locations

Game parameters are controlled by three sets of dip switch banks labeled SW1, SW2, SW3. Each bank eight switches where in the BANK SW2 for example refers to bank 2 switch position 2.

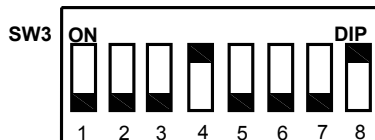
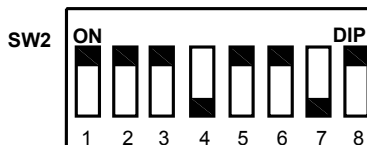
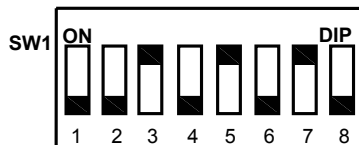
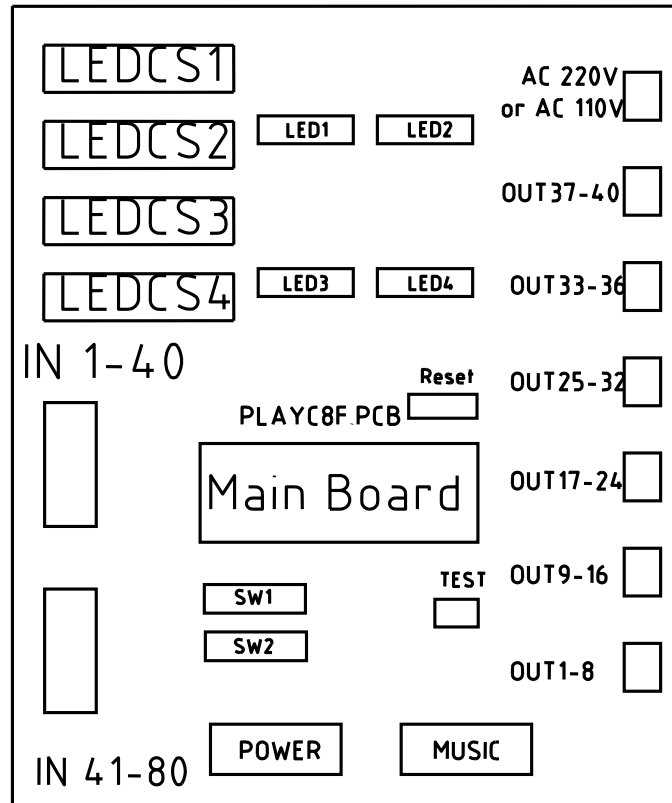

Note: Game parameters are subject change without notice.



Operation Manual

8. Adjustment

8.1 BOUNS initial value

Adjust it to set the bonus initial value of this game. There are 8 options for user to select. It controlled by BANK 1 SW1-3.

BOUNS initial value	Option	SW1	SW2	SW3	Note
BANK 1	0	on	on	on	BOUNS initial value is 0
	15	off	on	on	BOUNS initial value is 15
	25	on	off	on	BOUNS initial value is 25
	50	OFF	ON	OFF	BOUNS initial value is 50
	75	on	on	off	BOUNS initial value is 75
	100	off	on	off	BOUNS initial value is 100
	125	on	off	off	BOUNS initial value is 125
	150	off	off	off	BOUNS initial value is 150

8.2 BOUNS Increase:

This is the increment value for the game Bonus. Setting 1 will increment the bonus one for every coin inserted, 0 will turn the increment off. The 1/2 value will increment the Bonus one for every two coins inserted and the 1/3 will increment the Bonus one for every 3 coins inserted. It is controlled by BANK 1 SW4~SW5.



Operation Manual

BANK 1

Bonus increase	Options	SW4	SW5	Note
BANK 1	1/3	on	on	Increase 1 coin by insert 3coins
	1/2	OFF	ON	Increase 1 coin by insert 2coins
	0	on	off	No increase
	1	off	off	Increase 1 coin by insert 1coin

8.3 Small Wheel Group:

Adjust it to set the Group of this game. There are 8 options for user to select. It controlled by BANK 1 SW6-8.

BANK 1

Group	Option	SW6	SW7	SW8	Note
BANK 1	A1	on	on	on	The group is A1
	A2	off	on	on	The group is A2
	A3	on	off	on	The group is A3
	A4	off	off	on	The group is A4
	A5	on	on	off	The group is A5
	A6	OFF	ON	OFF	The group is A6
	A7	on	off	off	The group is A7
	A8	off	off	off	The group is A8

A1	3	5	4
A2	3	8	5
A3	3	10	6
A4	4	8	7
A5	4	10	7
A6	5	10	7
A7	5	10	8
A8	6	7	8



8.4 Payout

Payout	Option	SW1	SW2	Note
BANK 2	6	ON	ON	6tickets
	8	off	on	8 tickets
	10	on	off	10 tickets
	15	off	off	15 tickets

8.5 Middle Wheel Group:

Adjust it to set the Group of this game. There are 8 options for user to select. It controlled by BANK 2 SW3~SW5.

Group	Option	SW3	SW4	SW5	Note
BANK 2	B1	on	on	on	The group is B1
	B2	off	on	on	The group is B2
	B3	ON	OFF	ON	The group is B3
	B4	off	off	on	The group is B4
	B5	on	on	off	The group is B5
	B6	off	on	off	The group is B6
	B7	on	off	off	The group is B7
	B8	off	off	off	The group is B8

B1	6	8	5
B2	6	10	4
B3	7	10	7
B4	7	8	5
B5	8	10	6
B6	8	15	10
B7	8	10	7
B8	8	15	8



8.6 Demo delay:

Demo delay	Option (second)	SW6	SW7	Note
BANK 2	0	on	on	0
	15s	off	on	15 seconds
	30s	on	off	30 seconds
	60s	OFF	OFF	60 seconds

8.7 Top Wheel Group:

Adjust it to set the Group of this game. There are 16 options for user to select. It controlled by BANK 3 SW1~SW4.

Group	Option	SW1	SW2	SW3	SW4	Note
BANK 3	C1	on	on	on	on	The group is C1
	C2	off	on	on	on	The group is C2
	C3	on	off	on	on	The group is C3
	C4	off	off	on	on	The group is C4
	C5	on	on	off	on	The group is C5
	C6	off	on	off	on	The group is C6
	C7	on	off	off	on	The group is C7
	C8	OFF	OFF	OFF	ON	The group is C8
	C9	on	on	on	off	The group is C9
	C10	off	on	on	off	The group is C10
	C11	on	off	on	off	The group is C11
	C12	off	off	on	off	The group is C12
	C13	on	on	off	off	The group is C13
	C14	off	on	off	off	The group is C14
	C15	on	off	off	off	The group is C15
	C16	off	off	off	off	The group is C16



C1	10	12	14	16	18	20	10
C2	10	12	15	18	20	22	10
C3	8	10	12	15	17	19	8
C4	8	10	15	20	25	30	8
C5	6	8	10	12	15	20	6
C6	6	8	12	15	18	20	6
C7	6	10	6	8	10	8	6
C8	7	8	9	10	15	20	7
C9	10	15	20	25	30	15	10
C10	10	15	30	350	40	15	10
C11	10	15	35	40	45	15	10
C12	10	12	20	30	40	12	10
C13	10	5	15	20	25	5	10
C14	15	5	10	20	30	5	15
C15	15	5	20	25	30	5	15
C16	15	5	30	40	50	5	15

8.8 Coin per Game

Difficulty	Option	SW5	SW6			Note
BANK 3	1	on	on			1 coin per play
	2	off	on			2 coin per play
	3	on	off			3 coin per play
	4	off	off			4 coin per play

8.9 Wheel Speed

Wheel Speed	Option			SW7	SW8	Note
BANK 3	1			on	on	Slow
	2			off	on	Medium
	3			ON	OFF	Fast
	4			off	off	Fastest



9 Fault display

Input Errors

Input	Content	Input	Content	Input	Content	Input	Content
I1	Insert Coin A	I11		I21		I41	SW31
I2	Insert Coin B	I12		I22		I42	SW32
I3	Start SW	I13		I23		I43	SW33
I4	Ticket mech feedback	I14		I24		I44	SW34
I5	Ticket mech reset	I15		I25		I45	SW35
I6	Home position small wheel	I16		I26		I46	SW36
I7	Home position middle wheel	I17		I27		I47	SW37
I8	Home position big wheel	I18		I28		I48	SW38
I9		I19		I29		I49	
I10		I20		I30		I50	

Output Errors

Output	Content	Output	Content	Output	Content
Out1	Coins	Out11	Motor(middle)impulse	Out21	Moving lamp5
Out2	Payout	Out12	Motor(middle)direction	Out22	Moving lamp6
Out3	Start SW	Out13	Motor(big) impulse	Out23	Moving lamp7
Out4	Ticket driver	Out14	Motor(big) direction	Out24	Moving lamp8
Out5		Out15		Out25	
Out6		Out16		Out26	
Out7		Out17	Moving lamp1	Out27	
Out8		Out18	Moving lamp2	Out28	
Out9	Motor(small) impulse	Out19	Moving lamp3	Out29	
Out10	Motor(small) direction	Out20	Moving lamp4	Out30	



10. Overall construction



The electrical parts

A

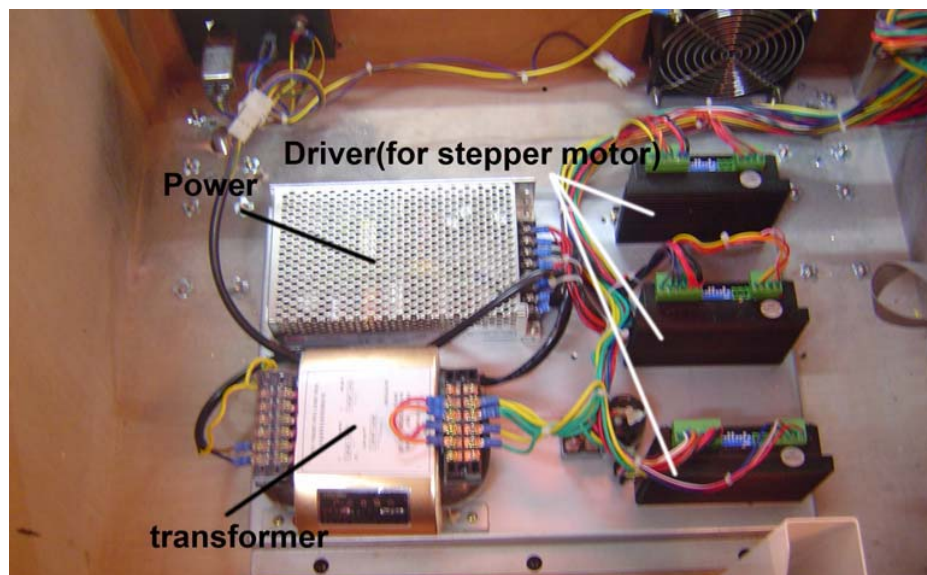



B

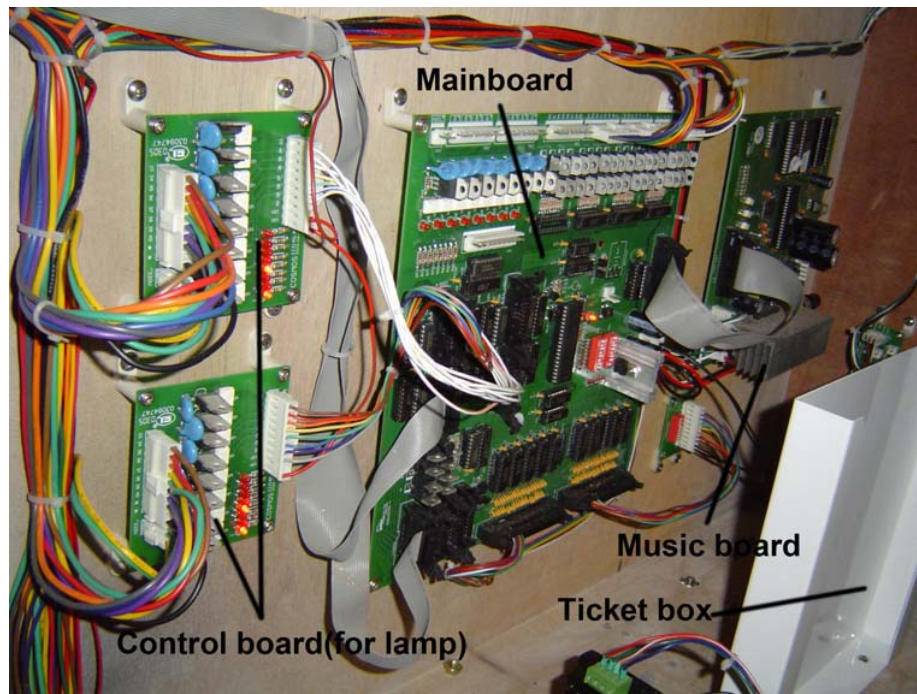

C

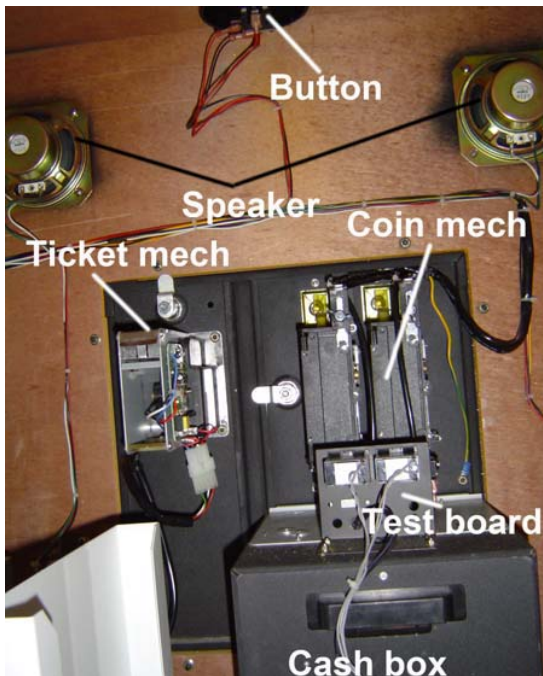



E



NO.	Name	Qty	Specification	Note
TS-1-1	LED	3		
TS-1-2	Button	1		
TS-1-3	Speaker	2		
TS-1-4	Coin Mech	1		
TS-1-5	Lamp	90		
TS-1-6	Diode	107		
TS-1-7	Caster	4		
TS-1-8	Driver	3		
TS-1-9	Power	1		
TS-1-10	Transformer	1		



Operation Manual

TS-1-12	Mainboard	1		
TS-1-13	Control board(for lamp)	2		
TS-1-14	Music Board	1		
TS-1-15	Ticket box	1		
TS-1-16	Ticket Mech	1		
TS-1-17	Coin Mech	2		
TS-1-18	Test board	1		
TS-1-19	Cash box	1		
TS-1-20	Fan	1		

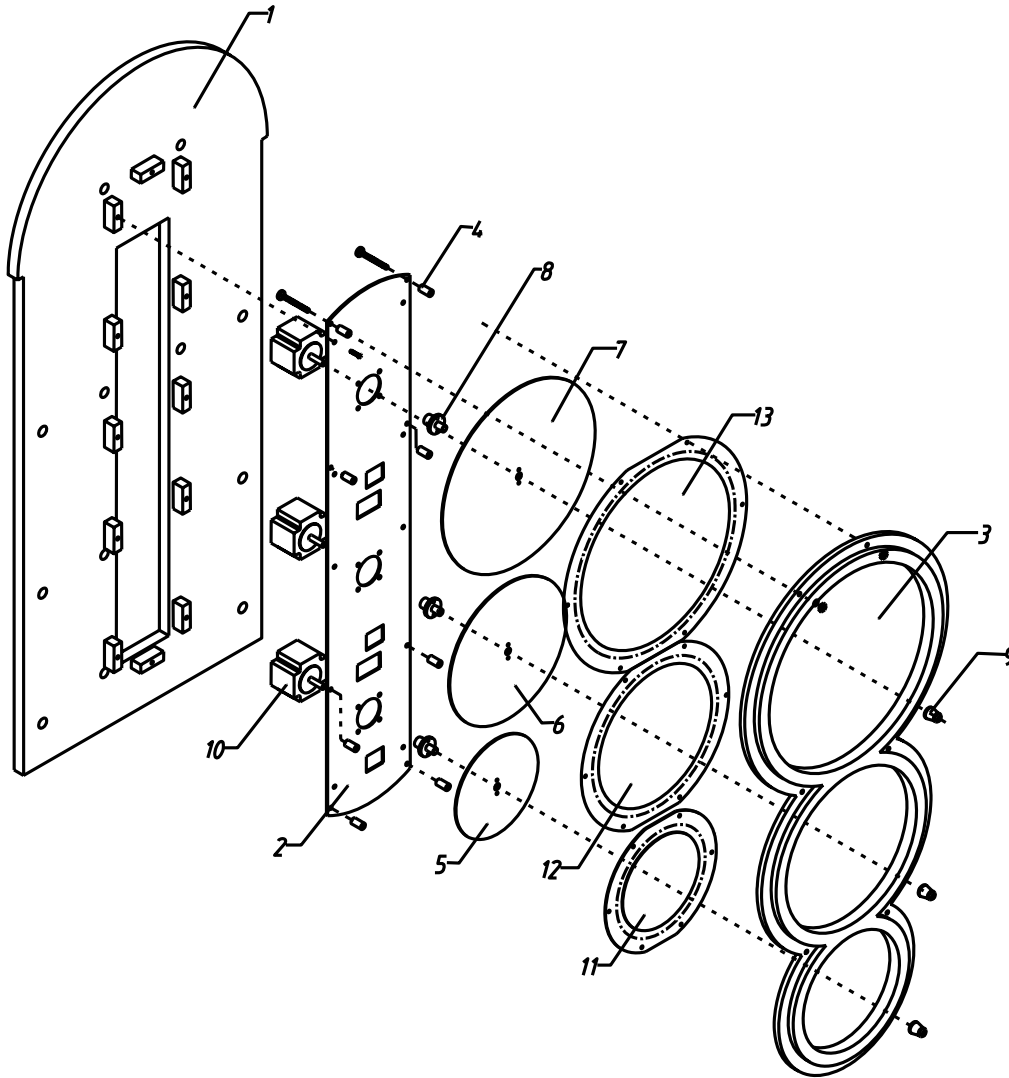



NO.	Name	Qty	Specification	Note
TS-2-1	Wheel Frame	1		
TS-2-2	Motor Frame	1		
TS-2-3	Outer Rings	1		
TS-2-4	Spacers	8		
TS-2-5	Wheel (small)	1		
TS-2-6	Wheel (middle)	2		
TS-2-7	Wheel (big)	1		
TS-2-8	Hub (轴冒)	3		
TS-2-9	Cap	3		
TS-2-10	Stepper Motor	3		
TS-2-11	Circuit Board1	1		
TS-2-12	Circuit Board2	1		
TS-2-13	Circuit Board3	1		
TS-2-14	Index	3		

Family Fun Companies, INC.

Parts, Service and Distribution

708-598-3720

Triple Spin I/O Chart (US Ver) V1.4

Update: 6/17/2007
Design: 10/25/2006

Item	Content	DIP Switch bank 1							
		1	2	3	4	5	6	7	8
JP Value	0	on	on	on					
	15	off	on	on					
	25	on	off	on					
	50	OFF	OFF	ON					
	75	on	on	off					
	100	off	on	off					
	125	on	off	off					
JP +	0				on	on			
	1				off	on			
	1/2				ON	OFF			
Small Wheel Group	1/3				off	off			
	A1						on	on	on
	A2						off	on	on
	A3						on	off	on
	A4						OFF	OFF	ON
	A5						on	on	off
	A6						off	on	off
	A7						on	off	off
A8						off	off	off	

Item	Content	DIP Switch bank 2							
		1	2	3	4	5	6	7	8
auto %	off	on	on	on					
	20%	off	on	on					
	25%	on	off	on					
	28%	off	off	on					
	30%	on	on	off					
	32%	OFF	ON	OFF					
Middle Wheel Group	35%	on	off	off					
	38%	off	off	off					
	B1				on	on	on		
	B2				off	on	on		
	B3				on	off	on		
	B4				OFF	OFF	ON		
	B5				on	on	off		
	B6				off	on	off		
Demo Delay	B7				on	off	off		
	B8				off	off	off		
	0						on	on	
	15s						off	on	
30s							on	off	
60s							OFF	OFF	

Item	Content	DIP Switch bank 3							
		1	2	3	4	5	6	7	8
Big Wheel Group	C1	on	on	on	on				
	C2	off	on	on	on				
	C3	on	off	on	on				
	C4	off	off	on	on				
	C5	on	on	off	on				
	C6	off	on	off	on				
	C7	on	off	off	on				
	C8	off	off	off	on				
	C9	ON	ON	ON	OFF				
	C10	off	on	on	off				
	C11	on	off	on	off				
	C12	off	off	on	off				
	C13	on	on	off	off				
	C14	off	on	off	off				
	C15	on	off	off	off				
	C16	off	off	off	off				
Coin per Game	1				ON	ON			
	2				off	on			
	3				on	off			
	4				off	off			
Wheel Speed	1						on	on	
	2						off	on	
	3						ON	OFF	
	4						off	off	

Note: Game Level 1 is the most easy level.
Wheel Speed 1 is the most lowest speed.
500ms each circle
480ms each circle
460ms each circle
440ms each circle

JP Area:
22°
20°
18°
16°
Each coin: 25T

Input:		Input:		Input:		Input:	
INPUT	Content	INPUT	Content	INPUT	Content	INPUT	Content
11	Coin1	111		121		141	SW31
12	Coin2	112		122		142	SW32
13	Start Button	113		123		143	SW33
14	TicketReset	114		124		144	SW34
15	TicketFeedback	115		125		145	SW35
16	Small wheelReset	116		126		146	SW36
17	Middle wheelReset	117		127		147	SW37
18	Big wheelReset	118		128		148	SW38
19		119		129		149	
110		120		130		150	

Output:		Output:		Output:		Output:	
OUTPUT	Content	OUTPUT	Content	OUTPUT	Content	OUTPUT	Content
OUT1	Coin Amount	OUT11	M_Wh_MotorP	OUT21	Ex_Lamp5#	OUT31	MarqueeLamp7#
OUT2	TicketAmount	OUT12	M_Wh_MotorD	OUT22	Ex_Lamp6#	OUT32	MarqueeLamp8#
OUT3	StartButtonLamp	OUT13	S_Wh_MotorPu	OUT23	Ex_Lamp7#	OUT33	
OUT4	TicketAssyDrive	OUT14	S_Wh_MotorD	OUT24	Ex_Lamp8#	OUT34	
OUT5	Coin lock1	OUT15		OUT25	MarqueeLamp1#	OUT35	
OUT6	Coin lock2	OUT16		OUT26	MarqueeLamp2#	OUT36	
OUT7		OUT17	Ex_Lamp1#	OUT27	MarqueeLamp3#	OUT37	
OUT8		OUT18	Ex_Lamp2#	OUT28	MarqueeLamp4#	OUT38	
OUT9	B_Wh_MotorPulse	OUT19	Ex_Lamp3#	OUT29	MarqueeLamp5#	OUT39	
OUT10	B_Wh_MotorDire	OUT20	Ex_Lamp4#	OUT30	MarqueeLamp6#	OUT40	

LED Display: Score/JP
LED<1>1-3

Small Wheel lighting: LED<3>-1 → 1# Lamp
LED<3>-3 → 2# Lamp
LED<3>-5 → 3# Lamp
LED<3>-7 → 4# Lamp
LED<3>-9 → 5# Lamp
LED<3>-11 → 6# Lamp
LED<3>-13 → 7# Lamp
LED<3>-15 → 8# Lamp

Middle Wheel Lighting: LED<5>-1 → 1# Lamp
LED<5>-3 → 2# Lamp
LED<5>-5 → 3# Lamp
LED<5>-7 → 4# Lamp
LED<5>-9 → 5# Lamp
LED<5>-11 → 6# Lamp
LED<5>-13 → 7# Lamp
LED<5>-15 → 8# Lamp

Big Wheel Lighting: LED<7>-1 → 1# Lamp
LED<7>-3 → 2# Lamp
LED<7>-5 → 3# Lamp
LED<7>-7 → 4# Lamp
LED<7>-9 → 5# Lamp
LED<7>-11 → 6# Lamp
LED<7>-13 → 7# Lamp
LED<7>-15 → 8# Lamp

Wrong Display:
If the input signal is not normal when you turn on the machine, the number of the SW with wrong will be display on the LED 1#.

The LED displays 8,7,6,5,4,3,2,1 and 87654321 at the same time. It test the LED is right or wrong.

Press the "test" button once again, now the LED displays "1", the LED<1>1-2 display the condition of the snap SW.
Press the "test" button again, the LED display "2", the LED displays the number of on-off SW.
Press the "test" button again, it displays "3".
Press the "test" button again, it displays "4", which is make sure the initial position adjustment.
Press the "test" button again, it displays "5", the OUT1-40 output with lighting.

Enter the test program:
You can enter test program by press the TEST button on the main board.

Score Group:

Small Wheel:	1	2	3
A1	2	3	4
A2	2	4	3
A3	3	4	3
A4	3	5	4
A5	3	6	4
A6	3	8	6
A7	4	7	6
A8	5	7	6

Middle Wheel:	1	2	3
B1	5	8	4
B2	6	8	4
B3	7	8	6
B4	7	8	5
B5	8	10	6
B6	8	15	10
B7	8	10	7
B8	8	15	8

Big Wheel:	1	2	3	4	5	6	7
C1	10	12	14	16	18	20	10
C2	10	12	15	18	20	22	10
C3	8	10	12	15	17	19	8
C4	8	10	15	20	25	30	8
C5	6	8	10	12	15	20	6
C6	6	8	12	15	18	20	6
C7	6	10	6	8	10	8	6
C8	7	8	9	10	15	20	7
C9	10	15	20	25	30	15	10
C10	10	15	30	350	40	15	10
C11	10	15	35	40	45	15	10
C12	10	12	20	30	40	12	10
C13	10	5	15	20	25	5	10
C14	15	5	10	20	30	5	15
C15	15	5	20	25	30	5	15
C16	15	5	30	40	50	5	15

DIP SW Location:

