

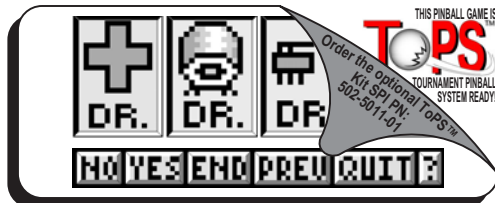

Find-It-In-Front: Dr. Pinball Section

The inside cover & the front pages
DR. 1 thru DR. 10 covers the basics...

Find the answers to your questions here...
If you still need help, give us a call!

Joe Blackwell
DIRECTOR,
Parts Sales &
Technical Support



Susan White
Parts
Sales
MANAGER



Patty Schraps
Parts
Stockroom
MANAGER

Your Parts Sales & Technical Support Team



Chas Siddiqi
Technical
Support
ENGINEER



Patrick Powers
Technical
Support
ENGINEER



J. Alfer
Technical Support
Documentation
ADMINISTRATOR

Please call us at 1-800-542-5377 or
1-800-KICKERS for Technical Support.
Visit us at our Web Site www.SternPinball.com.

Stern® Pinball, Inc.
All Rights Reserved. Printed in the U.S.A.
July 2004

SPI Part Number
780-5077-01

For Proper Operation of The Simpsons™ Pinball Party, five (5) Pinballs must be installed!

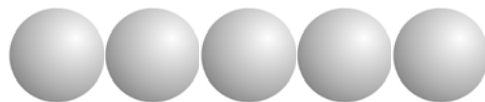

Removal of the 2nd Level (Upper) Mini-Playfield for Service or Access Underneath



Removal: There are three (3) Thumb Screws (*Black Knobs*) which secures the 2nd Level Mini-Playfield to the Support Posts. Two (2) are located just below the Mini-Flipper Bats, and the 3rd one is behind the Plastic Ramp.

You can now *carefully* move the playfield. **TAKE CARE!** when lifting so as not to damage the bulbs on the Back Panel.

If the playfield needs servicing outside or away from the game cabinet, note the wiring and connector harness from the TV Set (via the Back Panel Access Hole) and the remaining harnesses via the Main Playfield Access Hole (all of which need to be disconnected).

Reinstallation: After the Mini-Playfield is positioned back into place, hold down firmly while tightening the Thumb Screws. After all three knobs are secured, press down firmly with one hand on the playfield and **ensure there is no movement** (or play). If harnesses were disconnected, ensure they were all properly fed through the same access holes and the connectors are seated correctly.

It is always a good idea to enter Diagnostics (Begin Play Test) or play a game with the glass removed to ensure all switches, coils and lamps are still working properly.



Look over the **TOURNAMENT MENU** in Portals™!

Read over Section 3, Chapter 7, Pages 53-57.



An Optional Tournament Kit is required for this ToPS™ Ready Pinball Game.

You can now easily set-up, start and end Tournaments for cash, tokens, tickets or points!



New to our Pinball Games?

Don't forget to go over **Section 3, Chapter 1, Portals™ Service Menu Introduction**. *If using Diagnostics...very useful!* Got confused? Comments? Questions? Call Technical Support at 800-542-5377 or 708-345-7700 (Option 1).

Backbox PCB Fuses, ROMs, Bridges, Relays, P/F & Cabinet Fuses, Cab. Switches

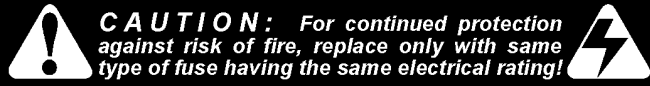

QUICK REFERENCE FUSE CHART

Backbox Fuses

LOC: DISPLAY POWER SUPPLY (P.S.) BOARD

F1	3/4A 250v S.B.	90v DC	High Voltage Display
----	----------------	--------	----------------------

LOC: I / O POWER DRIVER BOARD

F6	7A 250v S.B.	50v DC	Primary High Power Coils/Flippers
F7	5A 250v S.B.	20v DC	Low Power Coils
F8	5A 250v S.B.	12v DC	Logic Power
F9	5A 250v S.B.	12v DC	Logic Power
F20	3A 250v S.B.	50v DC	Magnet(s)/Auxilliary NOT USED
F21	3A 250v S.B.	50v DC	Coils
F22	8A 250v S.B.	18v DC	Controlled Lamps
F23	4A 250v S.B.	5v DC	Logic
F24	5A 250v S.B.	6.3v AC	G.I. Lamps (BRN-WHT to WHT-BRN)
F25	5A 250v S.B.	6.3v AC	G.I. Lamps (YEL to WHT-YEL)
F26	5A 250v S.B.	6.3v AC	G.I. Lamps (GRN to WHT-GRN)
F27	5A 250v S.B.	6.3v AC	G.I. Lamps (VIO to WHT-VIO)
F28	3A 250v S.B.	24v AC	Not Used / Spare

Cabinet Fuses

LOC: SERVICE (AC) OUTLET BOX (Cabinet Bottom)

n/a	8A 250v S.B.	115v AC	Main Fuse Line (Domestic or USA)
n/a	5A 250v S.B.	220v AC	Main Fuse Line (International)

Playfield (P/F) Fuses

LOC: UNDER PLAYFIELD (near Flippers)

n/a	3A 250v S.B.	50v DC	Rt. & Upr. Rt. Flips (BLU-YEL to RED-YEL)
n/a	3A 250v S.B.	50v DC	Left Flipper (GRY-YEL to RED-YEL)
n/a	3A 250v S.B.	50v DC	Upr. P/F Rt. Flip. (BLU-YEL to RED-YEL)
n/a	3A 250v S.B.	50v DC	Upr. P/F Lt. Flip. (GRY to RED-YEL)

For locations & more information on fuses, see Sec. 5, Chapter 2.

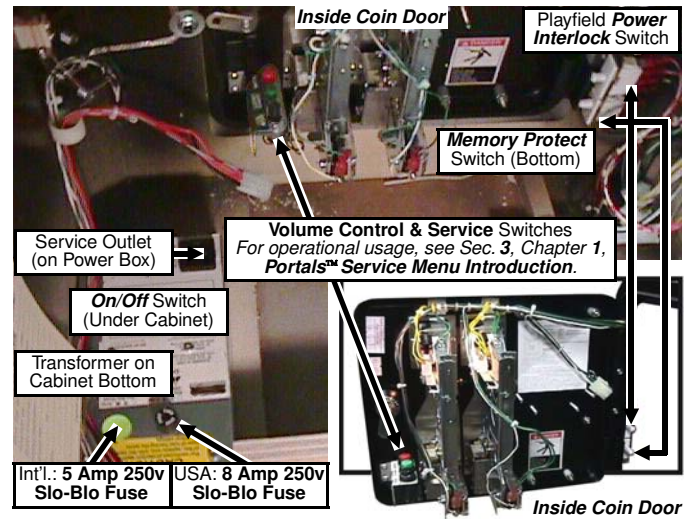

ROM TYPE on BD	LOCATION	SIZE	PART NUMBER
CPU Sound	U7	512K	965-0381-77
CPU Game	U210	1 MB	965-0382-77
CPU Voice ROM 1	U17	8 MB	965-0383-77
CPU Voice ROM 2	U21	8 MB	965-0384-77
CPU Voice ROM 3	U36	8 MB	965-0385-77
CPU Voice ROM 4	U37	8 MB	965-0386-77
DISPLAY Controller	U5	4 MB	965-0387-77

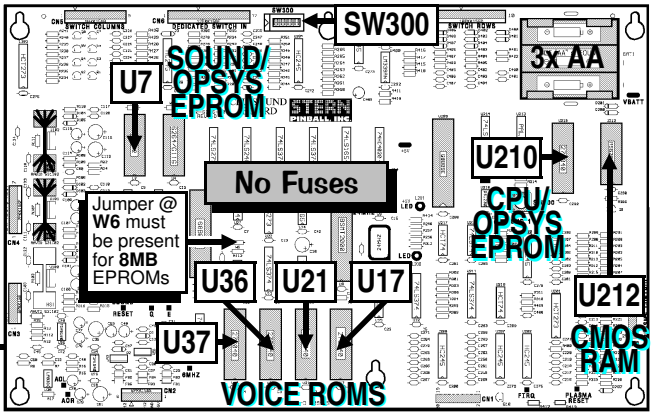
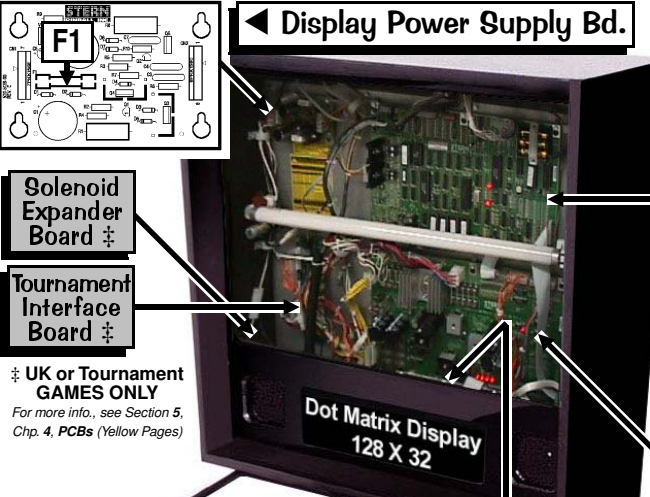

For Schematics and/or Component Parts on PC Boards shown on this page, review Section 5, Chapter 4, Printed Circuit Boards (The Yellow Pages).

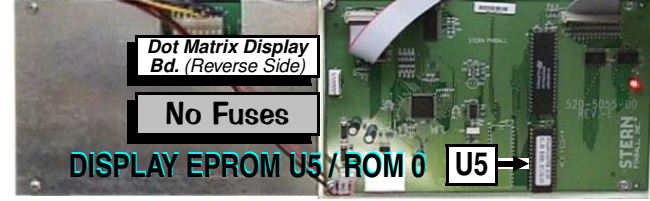
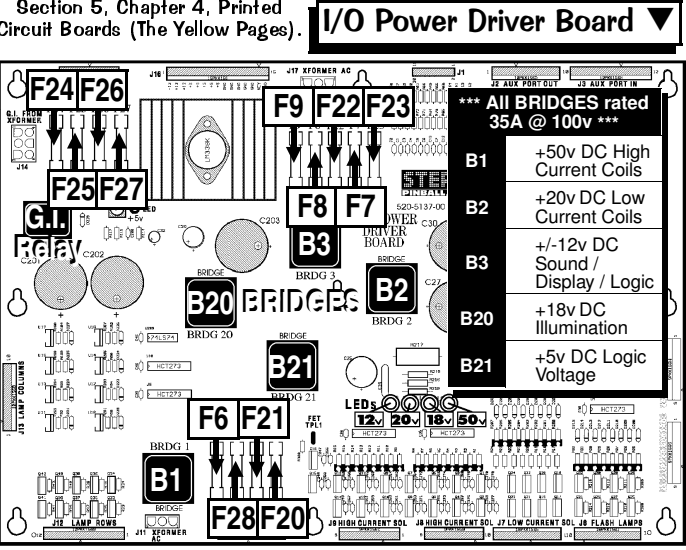
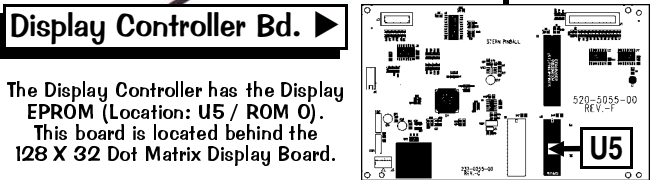

Find-It-In-Front:
Dr. Pinball



////// FIND-IT-IN-FRONT: Dr. Pinball Section Explained ////

The key technical data from various parts of the manual were extracted and combined into the "Find- It-In-Front: Dr. Pinball Section." This section (pages DR. ① - ⑩) will assist the technician in locating important technical information needed to troubleshoot the Pinball Machine. **Dr. Pinball** is also available in a Flow Chart Help Format in the Game Display. To access, enter the **Portals™ Service Menu**.

////// How It Works ////

First, the operator / technician must enter the **Service Menu Mode** (for a complete description of the **Portals™ Service Menu and ICONS Read! Section 3, Chapter 1**). To get into the **Service Menu Mode**, power-up the game (if not already) and open the **Coin Door**. On the **Coin Door** is the **Portals™ Service Switch Set** (Red, Green & Black Buttons).

Step 1: Push down the **Black "BEGIN TEST" Button**. Looking at the Video Display you will momentarily see the introductory screen followed by the **MAIN MENU**.

Step 2: Move through the Menus by pushing the **Red "LEFT"** or **Green "RIGHT"** Buttons.



Step 3: Select or activate the *Icons* by pushing the **Black "ENTER" Button**.

While in the **Portals™ Service Menu**, the **Start Button** can be used in lieu of the **Black Button**; the **Left & Right Flipper Buttons** can be used in lieu of the **Red & Green Buttons**. However, in *Switch or Active Switch Tests* **only** the **Red & Green Buttons** can be used.



In our **Portals™ Service Menu**, selecting the "DR." *Icon* will bring the operator/technician into **DR. PINBALL** (Flow Chart Menus), the "on-screen" diagnostic aide. This is a feature that will allow you to utilize the power of the micro-processor assisting in troubleshooting a problem with the machine in a **Flow Chart** format (follow the questions & answer by using the *Mini-Icons* in the display).



After entering **Portals™**, the **MAIN MENU** now appears with the "DIAG" *Icon* (GO TO DIAGNOSTICS MENU) flashing; press the **Black "ENTER" Button** to activate this **ICON**. The **DIAGNOSTICS MENU** now appears with the "SW" *Icon* (GO TO SWITCH MENU) flashing; use the **Red "LEFT"** or **Green "RIGHT"** Buttons, until the "DR." *Icon* (DR. PINBALL) is flashing:



Press the **Black "ENTER" Button** to activate this **ICON**. The **DR. PINBALL MENU** (Flow Chart Menus) now appears with the **COIL "DR." Icon** flashing. Three (3) *Icons*, **Coil "DR."**, **Switch "DR."** and **Lamp "DR."** are available for selection. Selecting a particular *Icon* will give you a choice of which specific **Coil** (any and all coil assemblies such as *Flippers, VUKs, Magnets, etc.*), **Switch** or **Lamp Circuit** needs to be diagnosed. After selection, *Dr. Pinball* will now display a question or a procedure to follow such as "Does the lamp turn on?" or "Check bridge rectifier BR-20, if short replace." When *Dr. Pinball* displays a question or requests a procedure, *Dr. Pinball* will expect a response such as "NO" or "YES". You the operator/technician must respond by using the **Red** or **Green Buttons** to "SELECT" a *Mini-Icon* and the **Black Button** to "ACTIVATE or ENTER" your selection.



For *Mini-Icons* explanations & details, see the end of **Section 3, Chapter 2, GO TO DIAGNOSTICS MENU, Dr. Pinball**.

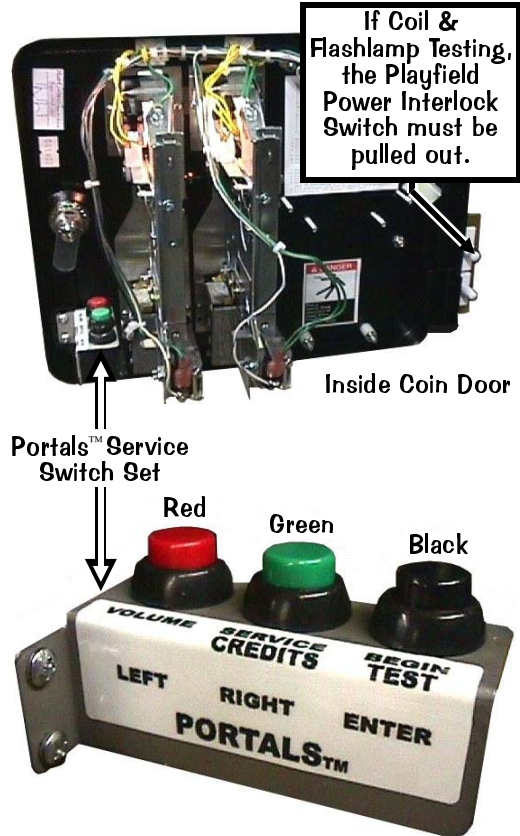

DIAGNOSTIC AIDS

OPEN THE DOOR

If this **display flashes**, the game is indicating that **CMOS RAM** memory (*CPU Loc. U212*) has been corrupted. This is caused by either failure in memory (*e.g. batteries are dead and/or faulty RAM*) or upon installation of updated version of game code. Opening the **Coin Door** will initiate a **Factory Restore (Reset)**, by opening the **Memory Protect Switch**. Check battery voltage at **VBATT Test Point** on the **CPU/Sound Bd.** (*more details in Section 5, Chapter 4, PCBs*).

OPERATOR ALERT! #2 AUTO LAUNCH COIL MALFUNCTION

This **display** is shown momentarily during **Game Mode** or **Power-Up** to alert the operator of a coil malfunction (*coil doesn't energize or coil fires a multiple number of times*). **OPERATOR ALERT!** works by monitoring any **switch activated coil** that has the potential to trap a ball when disabled (*e.g. in the Auto Launch, Scoop, Eject, etc.*). This alert can also appear if a switch associated with a coil (*e.g. #16 Shooter Lane & #2 Auto Launch*) is stuck closed (*caused by a switch jam or stuck ball*); the **CPU/Sound Board** will activate the coil approximately ten times and if the switch remains closed, the game will report this switch in **Technician Alerts** & will indicate the *following display warning*:

PLEASE CHECK TECH REPORT PORTALS->DIAG->TECH

If this **display flashes** (*along with an audible sound*), the game has detected faulty switches and/or missing pinballs. To check, enter the **Portals™ Service Menu System**, select the **"DIAG" Icon** (*GO TO DIAGNOSTICS MENU*) from the **MAIN MENU** and select the **"TECH" Icon** (*more details in Section 3, Chapter 2, GO TO DIAGNOSTICS MENU*).

CPU DIP SWITCH SETTINGS

Location of Dip Switch [SW300] is on the CPU/Sound Board (Right of CN6, Top Middle)

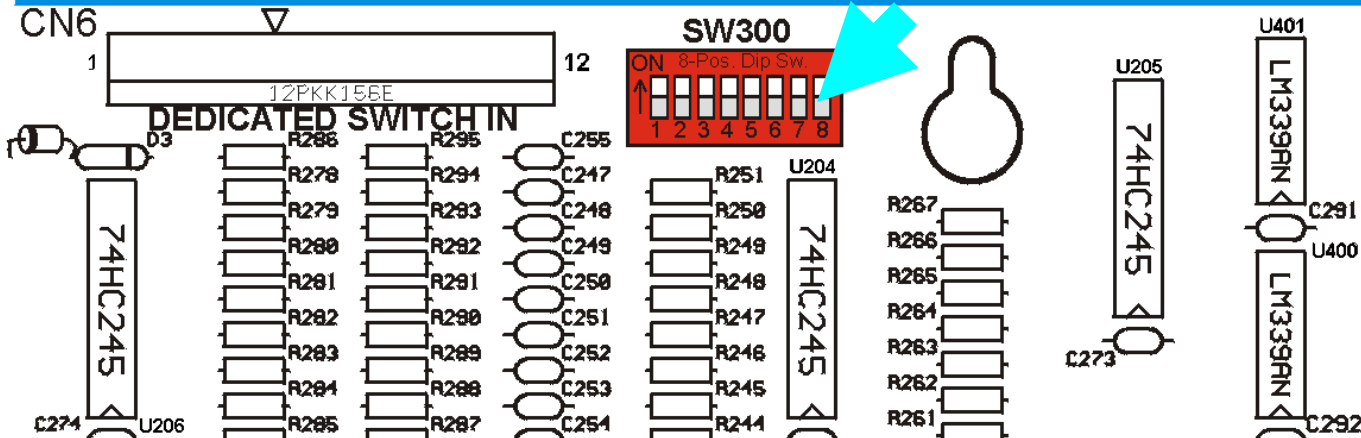

CPU COUNTRY SETTING:	Pos.	1	2	3	4	5	6	7	8
USA	ON	▲	▲	▲	▲	▲	▲	▲	▲
	OFF	▼	▼	▼	▼	▼	▼	▼	▼
Austria	ON	▲	▲	▲	▲	▲	▲	▲	▲
	OFF	▼	▼	▼	▼	▼	▼	▼	▼
Australia	ON	▲	▲	▲	▲	▲	▲	▲	▲
	OFF	▼	▼	▼	▼	▼	▼	▼	▼
Belgium	ON	▲	▲	▲	▲	▲	▲	▲	▲
	OFF	▼	▼	▼	▼	▼	▼	▼	▼
Canada	ON	▲	▲	▲	▲	▲	▲	▲	▲
	OFF	▼	▼	▼	▼	▼	▼	▼	▼
Denmark	ON	▲	▲	▲	▲	▲	▲	▲	▲
	OFF	▼	▼	▼	▼	▼	▼	▼	▼
Finland	ON	▲	▲	▲	▲	▲	▲	▲	▲
	OFF	▼	▼	▼	▼	▼	▼	▼	▼
France	ON	▲	▲	▲	▲	▲	▲	▲	▲
	OFF	▼	▼	▼	▼	▼	▼	▼	▼
Germany	ON	▲	▲	▲	▲	▲	▲	▲	▲
	OFF	▼	▼	▼	▼	▼	▼	▼	▼
Greece	ON	▲	▲	▲	▲	▲	▲	▲	▲
	OFF	▼	▼	▼	▼	▼	▼	▼	▼
Italy	ON	▲	▲	▲	▲	▲	▲	▲	▲
	OFF	▼	▼	▼	▼	▼	▼	▼	▼
Netherlands	ON	▲	▲	▲	▲	▲	▲	▲	▲
	OFF	▼	▼	▼	▼	▼	▼	▼	▼
New Zealand	ON	▲	▲	▲	▲	▲	▲	▲	▲
	OFF	▼	▼	▼	▼	▼	▼	▼	▼
Norway	ON	▲	▲	▲	▲	▲	▲	▲	▲
	OFF	▼	▼	▼	▼	▼	▼	▼	▼
Portugal	ON	▲	▲	▲	▲	▲	▲	▲	▲
	OFF	▼	▼	▼	▼	▼	▼	▼	▼
Spain	ON	▲	▲	▲	▲	▲	▲	▲	▲
	OFF	▼	▼	▼	▼	▼	▼	▼	▼
Sweden	ON	▲	▲	▲	▲	▲	▲	▲	▲
	OFF	▼	▼	▼	▼	▼	▼	▼	▼
Switzerland	ON	▲	▲	▲	▲	▲	▲	▲	▲
	OFF	▼	▼	▼	▼	▼	▼	▼	▼
UK	ON	▲	▲	▲	▲	▲	▲	▲	▲
	OFF	▼	▼	▼	▼	▼	▼	▼	▼



Find-It-In-Front:
Dr. Pinball

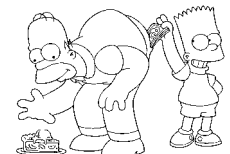



In SWITCH MENU also select:

ACTIVE and DEDICATED SWITCH TESTS

SWITCH MATRIX GRID, DEDICATED SWITCHES & LOCATIONS

Column (Drive)	1: Q1	2: Q2	3: Q3	4: Q4	5: Q5	6: Q6	7: Q7	8: Q8	GROUND	GROUND
Row (Return)	GRN-BRN CN5-P1	GRN-RED CN5-P3	GRN-ORG CN5-P4	GRN-YEL CN5-P5	GRN-BLK CN5-P6	GRN-BLU CN5-P7	GRN-VIO CN5-P8	GRN-GRY CN5-P9	IC U206 INPUTS	BLK CN6-P1, -P11
1: U400	1 Cabinet Side WHT-BRN CN7-P9 LEFT BUTTON (UK ONLY) Sw. Part Number: 180-5160-00	9 Below P/F COMIC BOOK GUY STANDUP 515-6027-08	17 Below P/F DROP TARGET #1 (TOP) 180-5158-00	25 Abv. Up. P/F UPPER PLAYFIELD EXIT 180-5190-28	33 Blw. Up. P/F UPF LIGHT STANDUP 515-5966-04	41 Below P/F BULLY 3-BANK (TOP) 515-6027-08	49 Below P/F LEFT BUMPER 180-5015-03	57 Below P/F LEFT OUTLANE 500-6227-02	1: U206 GRY-BRN CN6-P2 Sw. Part Number: 180-5160-00	DS-1 on Cabinet Side #1 LEFT FLIPPER BUTTON 180-5160-00
2: U400	2 Coin Door WHT-RED CN7-P8 4TH COIN SLOT 180-5204-00	10 Below P/F 5-BALL TROUGH #1 (LEFT) 180-5119-02	18 Below P/F DROP TARGET #2 (MID) 180-5158-00	26 Blw. Up. P/F GARAGE RAMP ENTER 180-5190-28	34 Blw. Up. P/F UPF LOCK STANDUP 515-5966-04	42 Below P/F BULLY 3-BANK (MID) 515-6027-08	50 Below P/F RIGHT BUMPER 180-5015-03	58 Below P/F LEFT RETURN LANE 500-6227-02	2: U206 GRY-RED CN6-P3 Sw. Part Number: 180-5149-00 on Flipper	DS-2 Below Playfield #2 LEFT FLIPPER E.O.S (End-of-Stroke) 180-5149-00 on Flipper
3: U400	3 Coin Door WHT-ORG CN7-P7 6TH COIN SLOT Sw. Part Number: Future Use	11 Below P/F 5-BALL TROUGH #2 180-5119-02	19 Below P/F DROP TARGET #3 (BOT) 180-5158-00	27 NOT USED	35 Blw. Up. P/F UPF TOP STANDUP 515-5966-02	43 Below P/F BULLY 3-BANK (BOT) 515-6027-08	51 Below P/F BOTTOM BUMPER 180-5015-03	59 Below P/F LEFT SLINGSHOT 180-5054-00 (x2)	3: U206 GRY-ORG CN6-P4 Sw. Part Number: 180-5164-00 Doubled	DS-3 on Cabinet Side #3 RIGHT FLIPPER BUTTON 180-5164-00 Doubled
4: U400	4 Coin Door WHT-YEL CN7-P6 RIGHT COIN SLOT 180-5204-00	12 Below P/F 5-BALL TROUGH #3 180-5119-02	20 Below P/F ITCHY & SCRATCHY SAUCER 180-5116-01	28 NOT USED	36 Abv. Up. P/F COUCH ENTER 180-5190-28	44 Above P/F UP RIGHT SAUCER BACKUP 180-5119-02	52 Below P/F POP SIDE STANDUP 515-6027-08	60 Below P/F RIGHT OUTLANE 500-6227-02	4: U206 GRY-YEL CN6-P6 Sw. Part Number: 180-5149-00 on Flipper	DS-4 Below Playfield #4 RIGHT FLIPPER E.O.S (End-of-Stroke) 180-5149-00 on Flipper
5: U401	5 Coin Door WHT-GRN CN7-P5 CENTER COIN SLOT / DBA 180-5204-00	13 Below P/F 5-BALL TROUGH #4 180-5119-02	21 Above P/F SPINNER 180-5010-04	29 Below P/F KWIK-E-MART LOOP 500-6227-02	37 Blw. Up. P/F TV LOCKUP 500-6227-02	45 Above P/F RIGHT RAMP ENTER 180-5190-28	53 In Cabinet TOURNAMENT BUTTON 180-5174-00	61 Below P/F RIGHT RETURN LANE 500-6227-02	5: U206 GRY-GRN CN6-P7 Sw. Part Number: 180-5164-00 Doubled	DS-5 on Cabinet Side #5 UPPER RT. FLIPPER BUTTON 180-5164-00 Doubled
6: U401	6 Coin Door WHT-BLU CN7-P3 LEFT COIN SLOT 180-5204-00	14 Below P/F 5-BALL TROUGH VUK OPTO See Sw. 14 Note	22 Below P/F BART SKATEBOARD TOP 180-5190-48	30 Below P/F KWIK-E-MART STANDUP 515-6027-08	38 Abv. Up. P/F COUCH LOCK (BOT) 180-5119-02	46 Above P/F RIGHT RAMP MADE 180-5190-28	54 In Cabinet START BUTTON 180-5174-00	62 Below P/F RIGHT SLINGSHOT 180-5054-00 (x2)	6: U206 GRY-BLU CN6-P8 Sw. Part Number: 180-5192-02	DS-6 on Coin Door #6 VOLUME (RED BUTTON) (In Test: LEFT) 180-5192-02
7: U401	7 Coin Door WHT-VIO CN7-P2 5TH COIN SLOT Sw. Part Number: Future Use	15 Below P/F 5-BALL STACKING OPTO See Sw. 15 Note	23 Below P/F BART SKATEBOARD 180-5190-48	31 Abv. Up. P/F ADV. POPS STANDUP 515-5966-07	39 Abv. Up. P/F COUCH LOCK (MID) 180-5119-02	47 Above P/F LEFT RAMP ENTER 180-5190-28	55 Below P/F UPPER LEFT VUK 180-5116-01	63 Below P/F LEFT ORBIT 500-6227-02	7: U206 GRY-VIO CN6-P9 Sw. Part Number: 180-5192-04	DS-7 on Coin Door #7 SERV. CRED. (GREEN BUTTON) (In Test: RIGHT) 180-5192-04
8: U401	8 Cabinet Side WHT-GRY CN7-P1 RIGHT BUTTON (UK ONLY) 180-5160-00	16 Below P/F SHOOTER LANE 180-5157-00	24 Below P/F UPPER RIGHT SAUCER 180-5186-00	32 Below P/F LIGHT OTTO STANDUP 515-5966-08	40 Abv. Up. P/F COUCH LOCK (TOP) 180-5119-02	48 Below P/F GARAGE DOOR 500-6138-01R	56 In Cabinet PLUMB BOB TILT See Sw. 56 Note	64 Below P/F RIGHT ORBIT 500-6227-02	8: U206 GRY-BLK CN6-P10 Sw. Part Number: 180-5192-00	DS-8 on Coin Door #8 BEGIN TEST (BLACK BUTTON) (In Test: ENTER) 180-5192-00

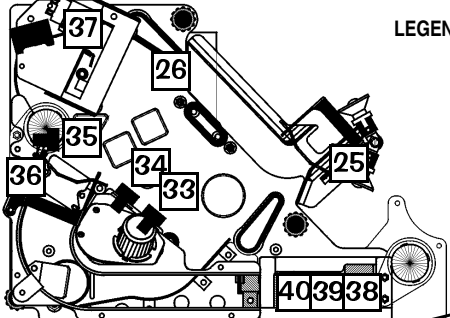
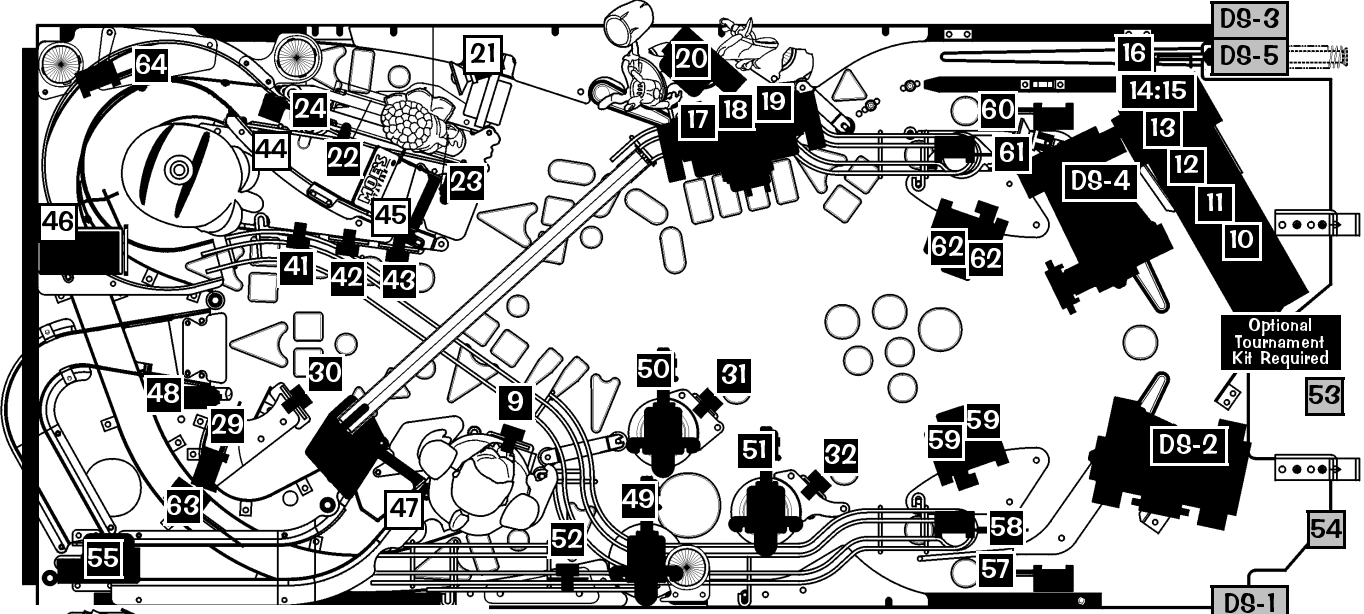

LEGEND NOTE: = Switches mounted above. = Switches mounted below. = ... mounted in the Cabinet.

Switch Part Note: ¥ Yen Coin Switch is 180-5091-00. Part numbers which start with 515- or 500- include the bracket, target, and/or housing. Targets: See Appendix I, Stand-Up Targets, for pictorial views. Switches are listed again in the Pink and Blue Pages and list the securing hardware they're used on.
Sw. 14 & 15 Part Note: Transmitter & Receiver OPTO PC Boards are used for both Switches 14 & 15. Transmitter: 515-0173-00; Receiver: 515-0174-00.
Switch 56 Part Note: The Switch is comprised of a Hanger Bracket (535-5319-00) and Contact Wire (535-7563-01) located in the Cabinet.

Some Switch Diodes are located under the playfield on Terminal Strips or Diode Boards and not on the assemblies. DOTS: Diode Qn Terminal Strip or DODB: Diode Qn Diode Board

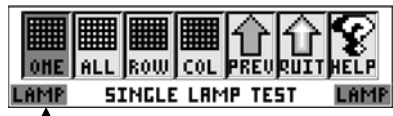

In LAMP MENU also select:

TEST ALL LAMPS, ROW & COLUMN LAMP TESTS

LAMP MATRIX GRID & LOCATIONS

Column (18v)	1: U17	2: U16	3: U15	4: U14	5: U13	6: U12	7: U11	8: U10
Row (Ground)	YEL-BRN J13-P9	YEL-RED J13-P8	YEL-ORG J13-P7	YEL-BLK J13-P6	YEL-GRN J13-P5	YEL-BLU J13-P4	YEL-VIO J13-P3	YEL-GRY J13-P1
1: Q33	#555 Bulb LEFT OUT EXTRA BALL	#555 Bulb LEFT RETURN EXTRA BALL	#555 Bulb SHOOT AGAIN	#555 Bulb RIGHT RETURN EXTRA BALL	#555 Bulb SPECIAL	#555 Bulb SHOOTER LANE SKILL SHOT	#555 Bulb LIGHT OTTO	#555 Bulb ADV. POPS
2: Q34	#555 Bulb SPAY ANYTHING	#555 Bulb KITTY KITTY BANG BANG	#555 Bulb FIELD OF SCREAMS	#555 Bulb ESOPHAGUS NOW	#555 Bulb I&S ARROW	#555 Bulb START I&S MULTIBALL	#555 Bulb I&S 2X SCORING	#44 Bulb (x2) POPS 2X SCORING
3: Q35	#555 Bulb LEFT POP BUMPER	#555 Bulb RIGHT POP BUMPER	#555 Bulb BOTTOM POP BUMPER	#555 Bulb MORE TIME	#555 Bulb COLLECT NUCLEAR PLANT	#555 Bulb LEFT ORBIT ARROW	#555 Bulb CLETUS 2X SCORING	#555 Bulb LEFT ORBIT HURRY UP
4: Q36	#555 Bulb CBG SKILL SHOT	#555 Bulb CGB START HURRY UP	#555 Bulb DAREDEVIL RAMP	#555 Bulb DAREDEVIL BUMPERS	#555 Bulb DAREDEVIL LOOPS	#555 Bulb DAREDEVIL TARGETS	#555 Bulb START BUTTON	#555 Bulb TOURNAMENT BUTTON
5: Q37	#555 Bulb LEFT RAMP ARROW	#555 Bulb TREEHOUSE OF HORROR	#555 Bulb TREEHOUSE 2X SCORING	#555 Bulb LEFT RAMP HURRY UP	#555 Bulb RIGHT RAMP ARROW	#555 Bulb GET DUFFED!	#555 Bulb MOE'S 2X SCORING	#555 Bulb RIGHT RAMP HURRY UP
6: Q38	#555 Bulb MINI LOOP ARROW	#555 Bulb 2X SCORING KWIK-E-MART	#555 Bulb KWIK-E-MART HURRY UP	#555 Bulb GARAGE ARROW	#555 Bulb CLEAN THE GARAGE	#555 Bulb GARAGE 2X SCORING	#555 Bulb GARAGE HURRY UP	#555 Bulb RIGHT ORBIT ARROW
7: Q39	#555 Bulb RIGHT LOOP ARROW	#555 Bulb OTTO'S BUS TOURS	#555 Bulb ELEMENTARY 2X SCORING	#555 Bulb BULLY 3-BANK (TOP)	#555 Bulb BULLY 3-BANK (MID)	#555 Bulb BULLY 3-BANK (BOT)	#555 Bulb KRUSTY 2X SCORING	#555 Bulb RIGHT ORBIT HURRY UP
8: Q40	#555 Bulb HOMER	#555 Bulb MARGE	#555 Bulb BART	#555 Bulb LISA	#555 Bulb MAGGIE	#555 Bulb GRANDPA	#44 Bulb LEFT HEADLIGHT	#44 Bulb RIGHT HEADLIGHT
9: Q41	#555 Bulb LIVING ROOM 2X SCORING	#555 Bulb (LIGHT) LOCK	#555 Bulb LIGHT (LOCK)	#555 Bulb LOCK (SQUARE)	#555 Bulb SUPER JACKPOT	#555 Bulb TV ARROW	NOT USED	NOT USED
10: Q42	Green LED (LED) DUFFMAN	Green LED (LED) HOMER'S DAY	Green LED (LED) WILLIE'S WOES	Green LED (LED) WIGGUM VS SNAKE	Green LED (LED) BART'S DAY	Green LED (LED) KRUSTY'S LAST STAND	Green LED (LED) STOP THE MONORAIL	Red LED (x2) (LED) ALIEN INVASION

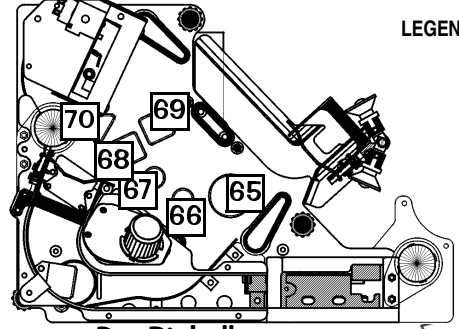
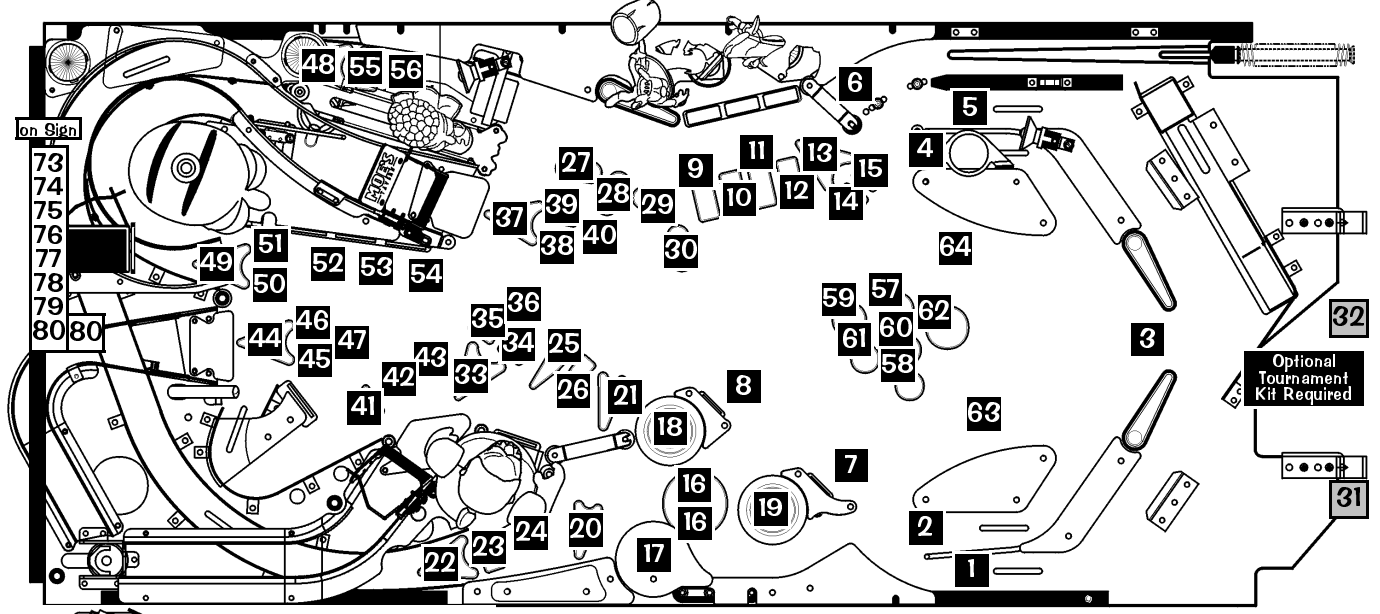

LEGEND NOTE: = Lamps mounted above. = Lamps mounted below. = Lamps mounted in the Cabinet.

Lamp Part Note: #555 Bulb Clear = 165-5002-00. #44 Bulb Clear = 165-5000-44. See Section 4, Chapter 1, Parts Id. & Location, Pages 72-74 for more details on bulbs and corresponding sockets.

Lamp Part Note: For Green or Red LEDs are attached to LED PC Bd., 520-5219-00. See Section 5, Chapter 4, Printed Circuit Boards (PCBs), Page 143.

Some Lamp Diodes are located under the playfield* on Terminal Strips or Diode Boards and not on the assemblies. DOTS: Diode On Terminal Strip or DODB: Diode On Diode Board
Lamp 31, Start Button: DOTS (2-Lug) in Cabinet under Button (RED-YEL / ORG-YEL to YEL-VIO).
Lamp 32, Tournament Button (Optional with Tournament Kit, Diode in Connector).

Dr. Pinball
Find-It-In-Front:





In COIL MENU
also select:

CYCLING
COIL
TEST

COILS DETAILED CHART TABLE

High Current Coils Group 1		Drive Transistor	Driver Output Board	Power Line Color	Power Line Connection	Power Voltage	Drive Transistor Control Line Color	D.T. Control Line Connect	Coil GA-Turn or Bulb Type
#1	TROUGH UP-KICKER	Q1	▲ I/O Power Driver ▼	YEL-VIO	J10-P4/5	50v DC	BRN-BLK	J8-P1	26-1200 090-5044-00T
#2	AUTO LAUNCH	Q2		YEL-VIO	J10-P4/5	50v DC	BRN-RED	J8-P3	26-1200 090-5044-00T
#3	COUCH RELEASE	Q3		YEL-VIO	J10-P4/5	50v DC	BRN-ORG	J8-P4	28-1050 090-5046-00
#4	DROPS RESET UP	Q4		YEL-VIO	J10-P4/5	50v DC	BRN-YEL	J8-P5	26-1200 090-5044-00T
#5	ITCHY & SCRATCHY EJECT (VUK)	Q5		YEL-VIO	J10-P4/5	50v DC	BRN-GRN	J8-P6	27-1500 090-5004-00T
#6	UPPER LEFT VUK	Q6		YEL-VIO	J10-P4/5	50v DC	BRN-BLU	J8-P7	26-1200 090-5044-00B
#7	TV RELEASE	Q7		YEL-VIO	J10-P4/5	50v DC	BRN-VIO	J8-P8	28-1050 090-5046-00
#8	HOMER HEAD	Q8		GRY-3A Fuse-BRN	J7-P1	20v DC	BRN-GRY	J8-P9	22-900 090-5020-20T
High Current Coils Group 2		Drive Transistor	Driver Output Board	Power Line Color	Power Line Connection	Power Voltage	Drive Transistor Control Line Color	D.T. Control Line Connect	Coil GA-Turn or Bulb Type
#9	LEFT BUMPER	Q9	▲ I/O Power Driver ▼	YEL-VIO	J10-P4/5	50v DC	BLU-BRN	J9-P1	26-1200 090-5044-00T
#10	RIGHT BUMPER	Q10		YEL-VIO	J10-P4/5	50v DC	BLU-RED	J9-P2	26-1200 090-5044-00T
#11	BOTTOM BUMPER	Q11		YEL-VIO	J10-P4/5	50v DC	BLU-ORG	J9-P4	26-1200 090-5044-00T
#12	UPF LEFT FLIPPER	Q12		GRY-3A Fuse-RED-YEL	J10-P1/2	50v DC	BLU-YEL	J9-P5	25-1800 090-5041-00T
#13	UPF RIGHT FLIPPER	Q13		BLU-YEL-3A Fuse-RED-YEL	J10-P1/2	50v DC	BLU-GRN	J9-P6	24-1570 090-5025-00T
#14	TOP RIGHT FLIPPER	Q14		BLU-YEL-3A Fuse-RED-YEL	J10-P1/2	50v DC	BLU-BLK	J9-P7	23-1100 090-5030-00T
#15	LEFT FLIPPER (50v RED/YEL)	Q15		GRY-YEL-3A Fuse-RED-YEL	J10-P1/2	50v DC	ORG-GRY	J9-P8	22-1080 090-5032-00T
#16	RIGHT FLIPPER (50v RED/YEL)	Q16		BLU-YEL-3A Fuse-RED-YEL	J10-P1/2	50v DC	ORG-VIO	J9-P9	22-1080 090-5032-00T
Low Current Coils Group 1		Drive Transistor	Driver Output Board	Power Line Color	Power Line Connection	Power Voltage	Drive Transistor Control Line Color	D.T. Control Line Connect	Coil GA-Turn or Bulb Type
#17	LEFT SLINGSHOT	Q17	▲ I/O Power Driver ▼	BRN	J7-P1	20v DC	VIO-BRN	J7-P2	23-800 090-5001-00T
#18	RIGHT SLINGSHOT	Q18		BRN	J7-P1	20v DC	VIO-RED	J7-P3	23-800 090-5001-00T
#19	UPPER RIGHT EJECT	Q19		BRN	J7-P1	20v DC	VIO-ORG	J7-P4	26-1200 090-5044-00T
#20	GARAGE DOOR (EJECT)	Q20		BRN	J7-P1	20v DC	VIO-YEL	J7-P6	26-1200 090-5044-00T
#21	FLASH: POPS CLEAR	Q21		ORG	J6-P10	20v DC	VIO-GRN	J7-P7	#906 Bulb 165-5004-00
#22	FLASH: R.RAMP RED	Q22		ORG	J6-P10	20v DC	VIO-BLU	J7-P8	#906 Bulb 165-5004-00
#23	FLASH: R.RAMP ORANGE	Q23		ORG	J6-P10	20v DC	VIO-BLK	J7-P9	#906 Bulb 165-5004-00
#24	OPTIONAL COIL	Q24		RED	J16-P7	5v DC	VIO-GRY	J7-P10	Opt. 5v
D lode O n T ermi n al S tri p (if noted)									
Low Current Coils Group 2		Drive Transistor	Driver Output Board	Power Line Color	Power Line Connection	Power Voltage	Drive Transistor Control Line Color	D.T. Control Line Connect	Coil GA-Turn or Bulb Type
#25	FLASH: ITCHY	Q25	▲ I/O Power Driver ▼	ORG	J6-P10	20v DC	BLK-BRN	J6-P1	#906 Bulb 165-5004-00
#26	FLASH: SCRATCHY	Q26		ORG	J6-P10	20v DC	BLK-RED	J6-P2	#906 Bulb 165-5004-00
#27	FLASH: HOMER HEAD	Q27		ORG	J6-P10	20v DC	BLK-ORG	J6-P3	#906 Bulb 165-5004-00
#28	FLASH: COUCH	Q28		ORG	J6-P10	20v DC	BLK-YEL	J6-P4	#906 Bulb 165-5004-00
#29	FLASH: COMIC BOOK GUY	Q29		ORG	J6-P10	20v DC	BLK-GRN	J6-P5	#906 Bulb 165-5004-00
#30	DROP BANK TRIPS	Q30		BRN	J7-P1	20v DC	BLK-BLU	J6-P6	32-1250 515-6916-01
#31	FLASH: UPF ORANGE	Q31		ORG	J6-P10	20v DC	BLK-VIO	J6-P7	#906 Bulb 165-5004-00
#32	FLASH: UPF RED	Q32		ORG	J6-P10	20v DC	BLK-GRY	J6-P8	#906 Bulb 165-5004-00
Note: In Test Flash Lamps Menu ("Flash" Icon), Flashers tested are all Flash Lamps located between Q1-Q32 (This Game: Q21-Q23, Q25-Q29, Q31-Q32)									
Auxiliary (UK ONLY)		Drive Transistor	Driver Output Board	Power Line Color	Power Line Connection	Power Voltage	Drive Transistor Control Line Color	D.T. Control Line Connect	Coil GA-Turn
AUX 1: LEFT UP/DOWN POST		Q1	Solenoid Expander Auxiliary	BRN	J7-P1	20v DC	WHT	CN2-P5	26-1200 090-5044-00T
AUX 2: CENTER UP/DOWN POST		Q2		BRN	J7-P1	20v DC	RED	CN2-P4	23-1100 090-5030-00T
AUX 3: RIGHT UP/DOWN POST		Q3		BRN	J7-P1	20v DC	ORG	CN2-P3	26-1200 090-5044-00T



COIL & FLASH LAMP LOCATIONS

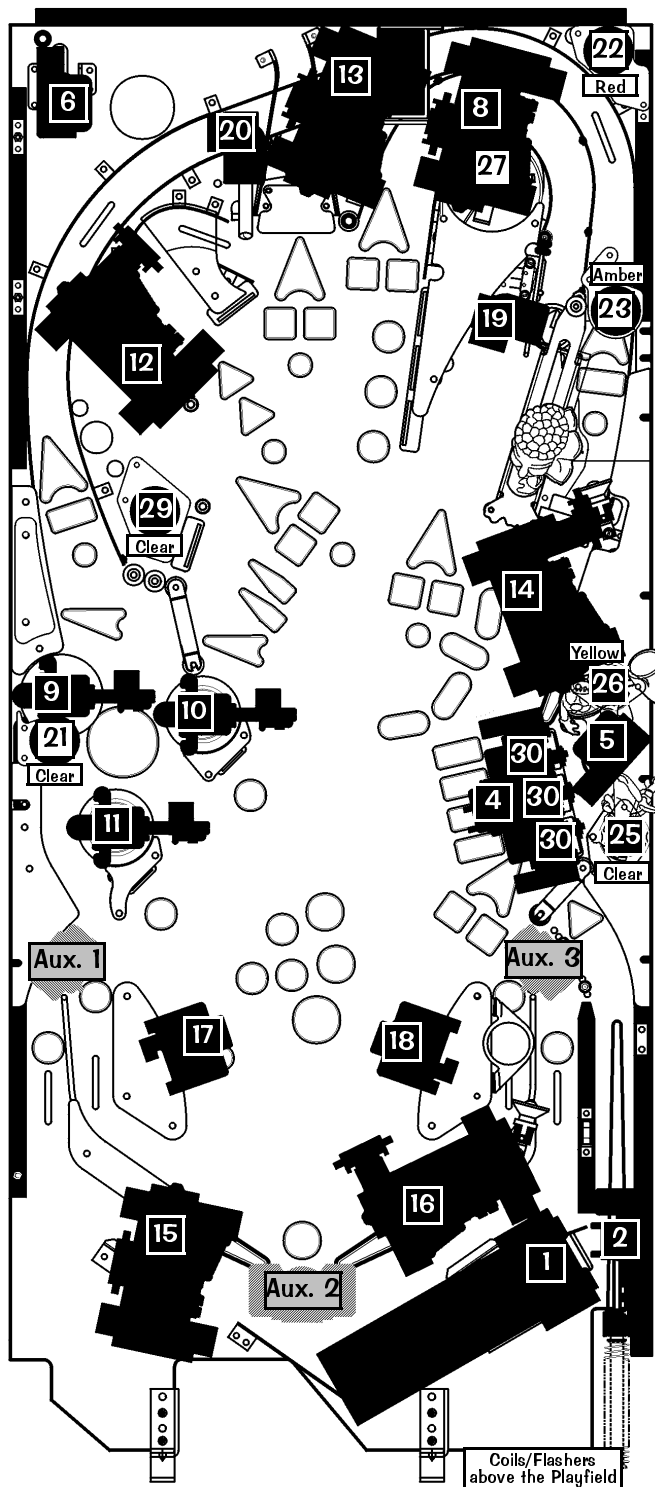

LEGEND NOTE:

- = Coils / Flash Lamps mounted above the Playfield.
- = Coils / Flash Lamps mounted below the Playfield.
- = Coils / Flash Lamps mounted in the Cabinet.

21
22
23
27

Coils/Flashers above the Playfield

Remaining Coils/Flashers are below

Flash Lamp Part Note: Color = Color of Mini-Mars over bulb.

Some Coil / Flash Lamp Diodes are located under the playfield on Terminal Strips or Diode Boards and not on the assemblies.

DOTS: Diode On Iterminal Strip or
 DODB: Diode On Diode Board (only if noted in the Chart Table).

Upper Playfield - Upper Right Corner

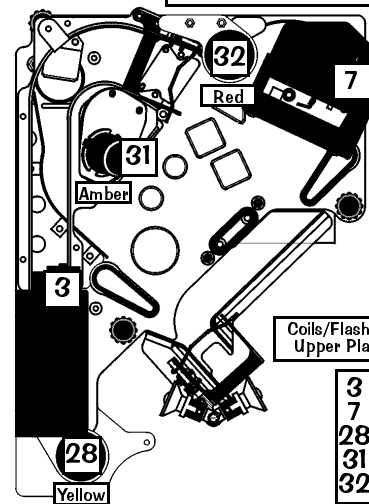

Coils/Flashers on Upper Playfield

7
28
31
32

Typical Switch Wiring & Schematic

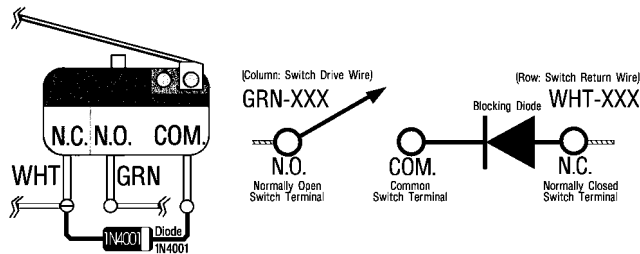

Dedicated Switch Schematic

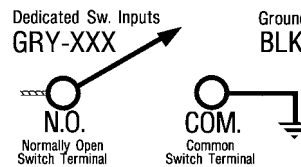

Typical Lamp Wiring & Schematic

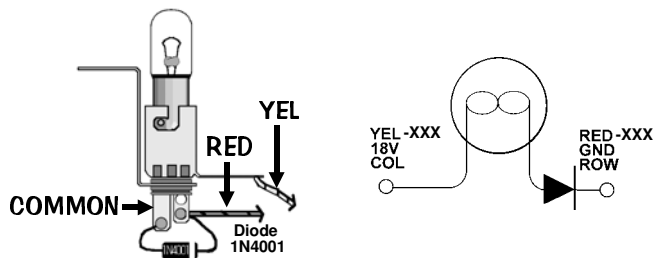

Typical Coil Wiring

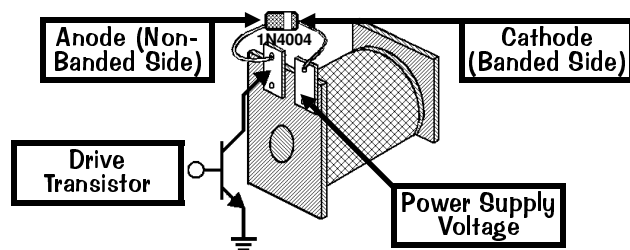

**Dr. Pinball
Find-It-In-Front:**



Domestic Pinball & Redemption Distributors Map

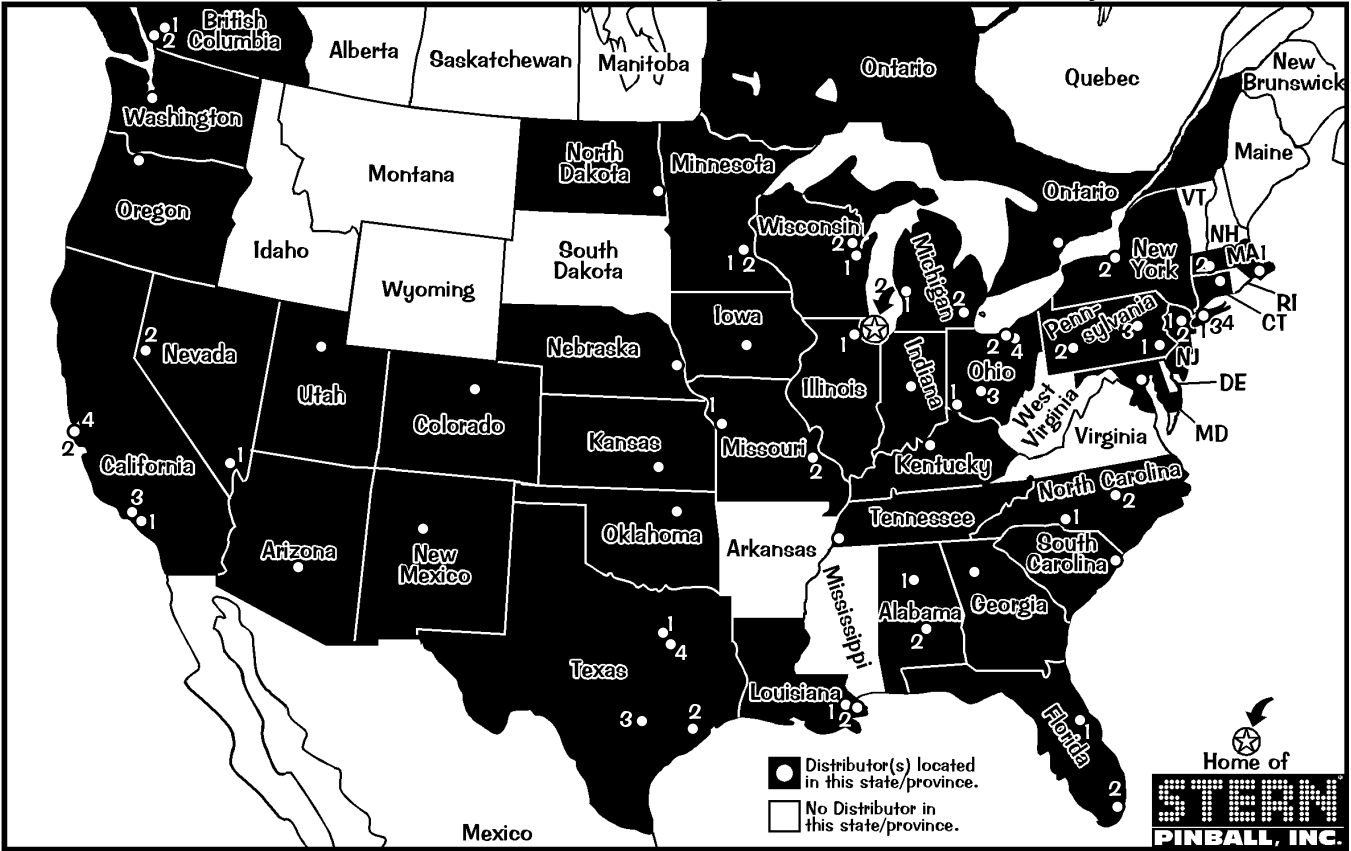

International Distributors Map

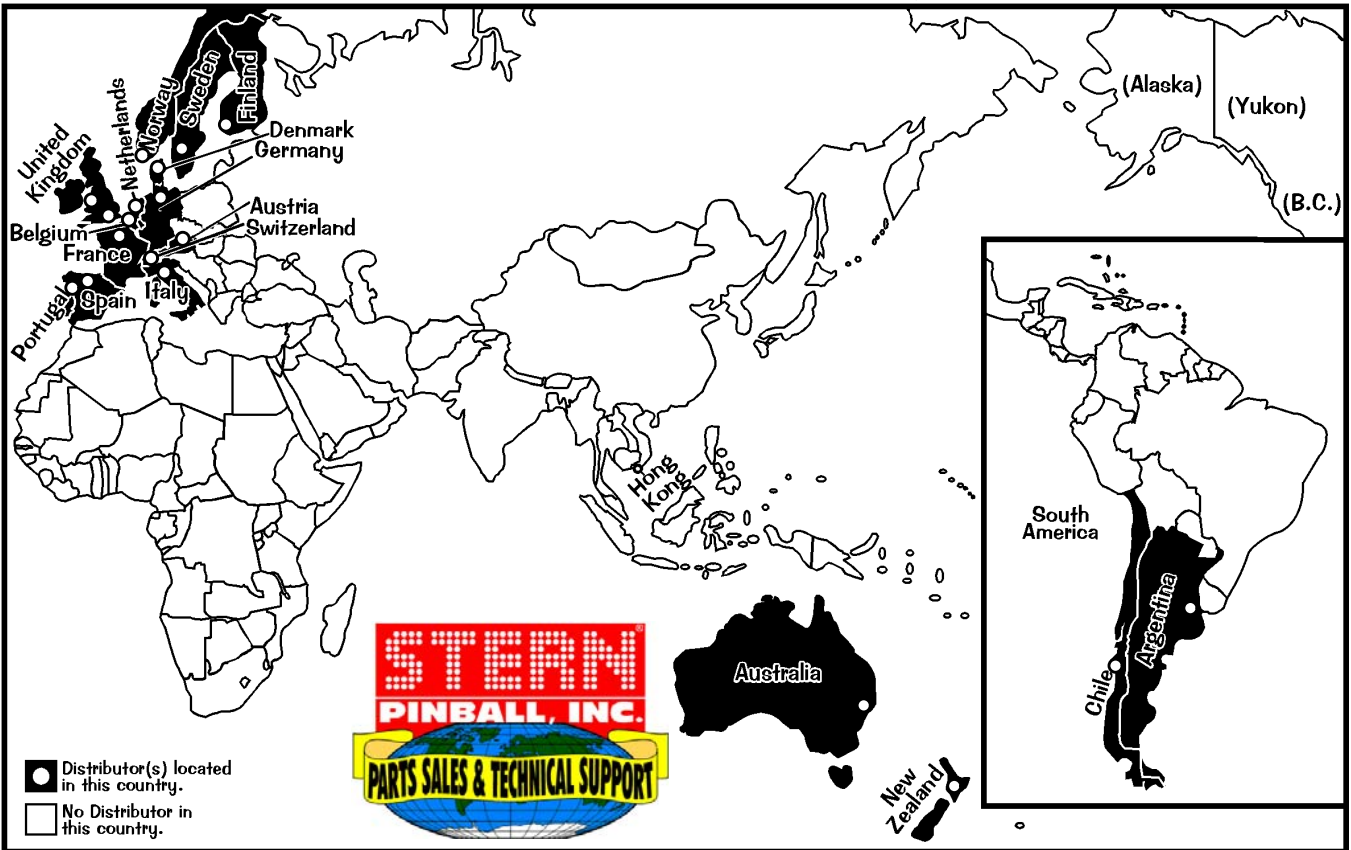

For *Parts & Service*, call your nearest Distributor. View the above maps & the directories on the next page to locate your closest Distributor in your state, province, or country. Distributors and phone numbers are subject to change. Call **Stern™ Pinball, Inc. (Parts Sales & Technical Support)** with any questions or if your Distributor cannot help you: 1-800-542-5377 (in USA or Canada) or 1-708-786-5466. Visit us at www.SternPinball.com for current Distributor Information & other pinball needs.



Domestic Pinball & Redemption Distributors Directory

<p>ALABAMA</p> <p>Birmingham Vending Birmingham (1) 1-205-324-7526</p> <p>Franco Distributing Montgomery (2) 1-334-834-3455</p> <p>ARIZONA</p> <p>Betsom West Phoenix 1-480-380-8857</p> <p>Mountain Coin Phoenix 1-602-269-7596</p> <p>CALIFORNIA</p> <p>Betsom West Buena Park (1) 1-714-228-7500</p> <p>So. San Francisco (2) 1-650-952-4220</p> <p>C.A. Robinson Los Angeles (3) 1-323-735-3001</p> <p>San Francisco (4) 1-650-871-4280</p> <p>COLORADO</p> <p>Mountain Coin Denver 1-303-427-2133</p> <p>CONNECTICUT</p> <p>TDM Distributing Williamantic 1-860-423-1403</p> <p>FLORIDA</p> <p>Birmingham Vending Orlando (1) 1-407-425-1505</p> <p>Brady Distributing Miami [Miramar] (2) 1-954-874-1100</p> <p>Orlando (1) 1-407-872-1666</p> <p>GEORGIA</p> <p>Greater Southern Dist. Smyrna 1-770-803-3040</p> <p>ILLINOIS</p> <p>American Vending Elk Grove Village (1) 1-847-439-9400</p> <p>Atlas Distributing Elk Grove Village (1) 1-847-952-7500</p> <p>World Wide Distributing Chicago (2) 773-384-2300</p>	<p>IOWA</p> <p>Greater America Dist. Johnston 1-515-278-4455</p> <p>Moss Distributing Des Moines 1-515-266-6422</p> <p>INDIANA</p> <p>Atlas Distributing Indianapolis 1-317-786-6892</p> <p>Shaffer Distributing Indianapolis 1-317-899-2530</p> <p>KANSAS</p> <p>United Dist., Inc. Wichita 1-316-263-6181</p> <p>KENTUCKY</p> <p>Atlas Distributing Louisville 1-502-966-5266</p> <p>LOUISIANA</p> <p>AMA Distributors, Inc. Metairie (1) 1-504-835-3232</p> <p>Parts & Service Only: New Orleans Novelty New Orleans (2) 1-504-888-3500</p> <p>MARYLAND</p> <p>Betsom Enterprises Baltimore 1-410-646-4100</p> <p>Parts & Service Only: Weiner Distributing Baltimore 1-410-525-2600</p> <p>MASSACHUSETTS</p> <p>Betsom Ent. (NECO) Norwood (1) 1-781-769-9760</p> <p>Gekay Sales E. Longmeadow (2) 1-413-525-2700</p> <p>MICHIGAN</p> <p>Atlas Distributing Wyoming (1) 1-616-241-1472</p> <p>Cleveland Coin Machine Livonia (2) 1-734-432-1040</p>	<p>MINNESOTA</p> <p>Lieberman Music Minneapolis (1) 1-952-887-5299</p> <p>Moss Distributing Richfield (2) 1-612-798-8030</p> <p>MISSOURI</p> <p>Greater America Dist. Kansas City (1) 1-816-531-4300</p> <p>Shaffer Distributing St. Louis (2) 1-314-645-3393</p> <p>NEBRASKA</p> <p>Central Dist. Omaha 1-402-493-5600</p> <p>Greater America Dist. Omaha 1-402-553-2812</p> <p>NEVADA</p> <p>Mountain Coin Las Vegas (1) 1-702-798-0900</p> <p>Reno Game Sales Reno (2) 1-775-829-2080</p> <p>NEW JERSEY</p> <p>Betsom Enterprises Carlstadt (1) 1-201-438-1300</p> <p>Jack Guarnieri Service Co., Inc. (Pinballsales.com) Lakewood (2) 1-732-364-9900</p> <p>NEW MEXICO</p> <p>Mountain Coin Albuquerque 1-505-345-7706</p> <p>NEW YORK</p> <p>Betsom Enterprises New Hyde Park (2) 1-516-354-4647</p> <p>Syracuse (3) 1-315-437-2400</p> <p>Parts & Service Only: Bay Coin Richmond Hill (1) 1-718-291-5757</p> <p>NORTH CAROLINA</p> <p>Brady Distributing Charlotte (1) 1-704-357-6284</p> <p>Operators Distributing Archdale (2) 1-336-884-5714</p>	<p>NORTH DAKOTA</p> <p>M.H. Associates, Inc. Fargo 1-701-282-7877</p> <p>OHIO</p> <p>Atlas Distributing Cincinnati (1) 1-513-851-4100</p> <p>Cleveland Coin Cleveland (2) 1-216-692-0960</p> <p>Shaffer Distributing Columbus (3) 1-614-421-6800</p> <p>Macedonia (4) 1-330-467-4850</p> <p>OKLAHOMA</p> <p>Galaxy Distributing Tulsa 1-918-835-1166</p> <p>OREGON</p> <p>Betsom West Portland 1-503-772-4567</p> <p>Mountain Coin Portland 1-503-234-5491</p> <p>Specialty Coin Products Portland 1-503-786-9200</p> <p>Toll-Free 1-800-987-4946</p> <p>PENNSYLVANIA</p> <p>Betsom Enterprises King Of Prussia (1) 1-610-265-1155</p> <p>Pittsburgh (2) 1-412-331-8703</p> <p>Cleveland Coin Machine Pittsburgh (2) 1-412-920-1300</p> <p>Roth Novelty (Superior) Wilkes-Barre (3) 1-570-824-9994</p> <p>SOUTH CAROLINA Parts & Service Only: Green Coin Myrtle Beach 1-843-626-1900</p> <p>TENNESSEE</p> <p>Brady Distributing Memphis 1-901-345-7811</p> <p>Parts & Service Only: Green G.A.M.E.S. Memphis 1-901-353-1000</p>	<p>TEXAS</p> <p>Amusement Distributors San Antonio (3) 1-210-225-3844</p> <p>Commercial Music Dallas (1) 1-214-741-6381</p> <p>H.A. Franz, & Co. Houston (2) 1-713-523-7366</p> <p>San Antonio (3) 1-210-226-6322</p> <p>Master Sales Corsicana (4) 1-903-874-4740</p> <p>Spirit Consulting Dallas (1) 1-214-638-4900</p> <p>UTAH</p> <p>Mountain Coin Salt Lake City 1-801-262-5494</p> <p>Struve Distributing Salt Lake City 1-801-328-1636</p> <p>WASHINGTON</p> <p>Mountain Coin Seattle 1-206-682-5700</p> <p>WISCONSIN</p> <p>Pioneer Sales & Svc. Green Bay (1) 1-920-336-5800</p> <p>Menomonee Falls (2) 1-262-781-1420</p> <p>Lieberman/Viking Vend. Menomonee Falls (2) 1-262-703-4168</p>	<p>CANADA</p> <p>ONTARIO</p> <p>Starburst Coin Mach. Toronto 1-416-251-2122</p> <p>BRITISH COLUMBIA Parts & Service Only: Can. Coin Machine Burnaby (1) 1-604-420-4008</p> <p>Parts & Service Only: Pacific Vending Vancouver (2) 1-604-324-2164</p>
---	---	--	---	--	---

Note: For states and Canadian Provinces which do not have Distributors, call the neighboring state or province with the city closest to you (indicated with a white dot). States or Provinces with more than 1 city containing a distributor are numbered. View the map on the previous page.

Note: Distributors are subject to change. Visit us at www.SternPinball.com for current Distributor Information.

International Distributors Directory

<p>ARGENTINA</p> <p>Electroport (Florenca) Mar Del Plata [54] 22-3495-5532</p> <p>AUSTRALIA</p> <p>Amusement Mach. Dist. Matraville [61] 2931-66000</p> <p>AUSTRIA</p> <p>TAB Ansfelden [43] 72-297-8660</p> <p>Parts & Service Only: R. Rupp Kaindorf, Austria [43] 3452-86105</p>	<p>BELGIUM</p> <p>Namusco Brussels [32] 2414-4596</p> <p>CHILE</p> <p>Cuinsa Santiago [56] 2641-8520</p> <p>DENMARK</p> <p>Vendcomatic (Oslo, Norway) [47] 2291-8383</p> <p>FINLAND</p> <p>Pelika Ray-Oy Espoo [35] (0) 5892-90452-99</p>	<p>FRANCE</p> <p>Avranches Automatic Ducey [33] 2338-96162</p> <p>SFA Paris [33] 1532-68082</p> <p>GERMANY</p> <p>Bergmann Automaten Hamburg [49] 4101/30 24-0</p> <p>HONG KONG</p> <p>Topfull Amusement Mach. Kowloon [85] 2278-10456</p>	<p>ITALY (RSM)</p> <p>Tecnoplay S.A. San Marino [39] 5499-00361</p> <p>NETHERLANDS</p> <p>JVH Gaming Products Tilburg [31] 13-595-3200</p> <p>NEW ZEALAND</p> <p>Coin Cascade Ltd. Christchurch [64] 3338-1411</p> <p>Parts & Service Only: Amco Machine Supplies Auckland, New Zealand [64] 9846-7606</p>	<p>NORWAY</p> <p>Vendcomatic Oslo [47] 2291-8383</p> <p>PORTUGAL</p> <p>Jacinto & Martins, S.A. Belas [35] 1214-325624/38</p> <p>SPAIN</p> <p>Comercial Cocomatic Madrid [34] 9167-16980</p> <p>SWEDEN</p> <p>Bjuvia Fritid AB Bjuv [46] 4238-6900</p>	<p>SWITZERLAND</p> <p>Novomat, A.G. Harkingon [41] 6238-88961</p> <p>UNITED KINGDOM</p> <p>Electrocoin London, England [44] 2089-652055</p> <p>Parts & Service Only: Electrocoin AfterSales Cardiff, S. Wales [44] (0) 2920 343888</p>
--	---	---	---	--	--



**Find-It-In-Front:
Dr. Pinball**



POWER REQUIREMENTS



This game **must be connected to a properly grounded outlet to reduce shock hazard** & insure proper game operation. See *Sec. 5, Schematics & Troubleshooting, Chp. 3, Cabinet Wiring (Transformer Power Wiring)*, for transformer connections required for **Normal, High, and Low Line** conditions.



Normal Line:		110v AC - 125v AC @ 60Hz	
Domestic use an 8AMP 250v Slo-Blo Fuse.	AVG OPERATION	CURRENT: 2.8AMP WATTAGE: 329w	MAX OPERATION CURRENT: 8AMP WATTAGE: 940w
	High Line: use 2x 5AMP 250v Slo-Blo Fuses. (*England & Hong Kong use an 8AMP 250v S/B Fuse.)		218v AC - 240v AC @ 50Hz AVG OPERATION CURRENT: 1.8AMP WATTAGE: 412w
Export use 2x 5AMP 250v Slo-Blo Fuses. (*England & Hong Kong use an 8AMP 250v S/B Fuse.)	MAX OPERATION	CURRENT: 5AMP 8AMP* WATTAGE: 1145w 1832w*	England & Hong Kong use an 8A Fuse.
	Low Line: use an 8AMP 250v Slo-Blo Fuse.		95v AC - 108v AC @ 50Hz / 60Hz AVG OPERATION CURRENT: 2.6AMP WATTAGE: 264w

TRANSPORTATION

GAME DIMENSIONS

BEFORE TRANSPORTING



To reduce the possibility of damage, observe **ALL** precautions whenever transporting the game.

Read & follow Section 1, Chapter 1, Pinball Game Set-Up Procedures, and How to Secure the Backbox for Transporting. Remove the legs and secure the game within the transporting vehicle.

SAVE AND RETAIN ALL PRINTED INFORMATION INSIDE THE CABINET !

Shipping Box Dimensions

Height 56" Width 31"
 Depth 31"
 Approx. Unboxed Weight: 270lbs. (+/- 10)
 Boxed Weight: Wt. 290lbs. (+/- 5)

CAUTION

At least 2 people are required to move and maneuver this game. Use proper moving equipment & extreme care while handling!

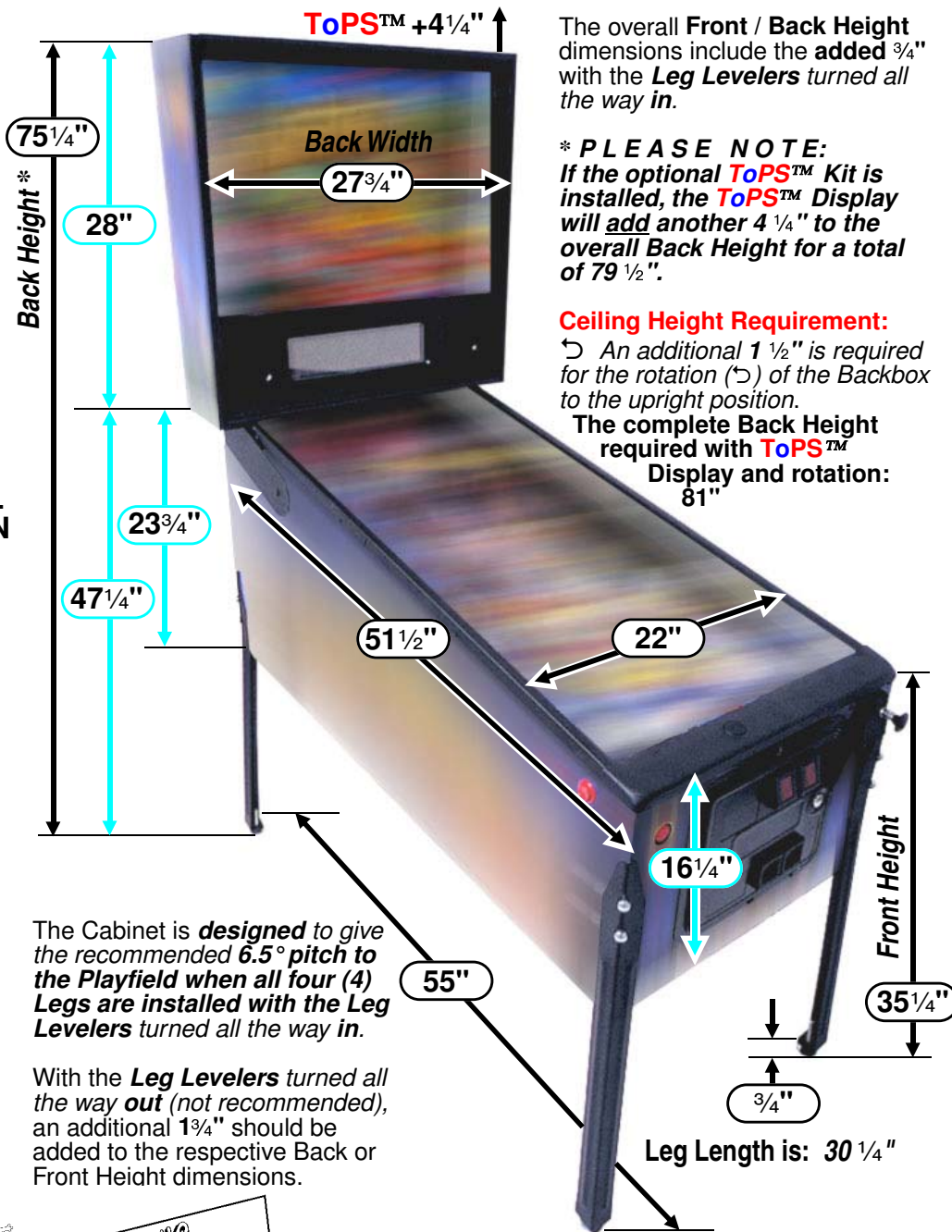

The overall **Front / Back Height** dimensions include the **added 3/4"** with the **Leg Levelers** turned all the way in.

*** PLEASE NOTE:** If the optional **ToPS™** Kit is installed, the **ToPS™** Display will add another 4 1/4" to the overall **Back Height** for a total of 79 1/2".

Ceiling Height Requirement:
 ↪ An additional 1 1/2" is required for the rotation (↪) of the Backbox to the upright position.
 The complete **Back Height** required with **ToPS™** Display and rotation: 81"

The Cabinet is **designed** to give the recommended **6.5° pitch** to the **Playfield** when all four (4) **Legs** are installed with the **Leg Levelers** turned all the way in.

With the **Leg Levelers** turned all the way **out** (not recommended), an additional 1 3/4" should be added to the respective **Back** or **Front Height** dimensions.





The Simpsons™ Pinball Party Pinball Game Service Manual General Table of Contents

See Sections 3 & 5, Table Of Contents, for details of that Section and it's Chapters.

For Proper Operation of ... five (5) Pinballs must be installed!.....Inside Front
▶ Backbox PCB Fuses, ROMs, Bridges, Relays Playfield/Cabinet Fuses, Cab. Switches . DR. ①
▶ Find-It-In-Front: Dr. Pinball Section Explained ▶ How It Works DR. ②
▶ Diagnostic Aids ▶ CPU DIP Switch Setting DR. ③
▶ Switch Matrix Grid, Dedicated Switches & Locations DR. ④
▶ Lamp Matrix Grid & Locations DR. ⑤
▶ Coils Detailed Chart Table DR. ⑥
▶ Coil & Flash Lamp Locations DR. ⑦
▶ Domestic Pinball & Redemption and International Distributors Maps..... DR. ⑧
▶ Domestic Pinball & Redemption and International Distributors Directories DR. ⑨
▶ Power Requirements ▶ Transportation ▶ Game Dimensions DR. ⑩
Game Manual General Table of Contentsi-ii
SECTION 11-4
Chapter 1, After Set-Up..... 1
▷ Pinball Game Set-Up Procedures.....1
▷ Pinball Game Set-Up Future Reference.....2-3
▷ How to Secure the Backbox... ▷ Leg Leveler Adjustment ▷ Easy Access... - 3 Positions..... 4
SECTION 25-6
Chapter 1, Game Operation & Features 5
▷ Start of Game Features (Starting a Normal Game, ... Team Play, ... Tournament Play with ToPS™)
▷ During Game Features (Feature Mode & Combination Shots, Multiball, Replay Feature)
▷ End of Game Features (Game Endings, Match Features, Entering Initials/Name) 5
▷ Auto Percentaging ▷ Instruction Card 6
SECTION 3 7-54
▷ Portals™ Service Menu System Table of Contents (detailed outline of this section)..... 7
▷ Portals™ Service Switch Set Access & Use (Function 1, ...; Function 2, ...; Function 3, ...) 8
Chapter 1, Portals™ Service Menu Introduction..... 9
▷ How to Use This Section..... 9
▷ Portals™ Service Menu Icon Tree10-11
▷ Portals™ Service Menu Example ▶ Exiting the Portals™ Service Menu12-14
Chapter 2, Go To Diagnostics Menu 15-31
Chapter 3, Go To Audits Menu 32-37
Chapter 4, Go To Adjustments Menu..... 38-46
Chapter 5, Go To Installs Menu 47-50
Chapter 6, Go To Reset Menu..... 51-52
Chapter 7, Go To Tournament Menu 53-57
SECTION 4 58-74
Chapter 1, Parts Identification & Location (The Pink Pages) 59
Overview..... 59
The Simpsons™ Pinball Party Backbox Assembly..... 60
Speaker Panel Assy. for the Backbox & Associated Parts: 61
Cabinet - General Parts & Switches62-63
Main Playfield - General Parts, Metal Rails/Ball Guides & Switches (Above).....64-65
Main Playfield - General Parts & Switches (Below) 66
Main Playfield & Mini-Playfield - Plastics (Screened & Clear) & Decals 67
Main Playfield - Rubber Parts Red & Black (Rings Actual Size) 68
Section 4, Chapter 1, Parts Identification & Location (The Pink Pages) Continued on the Next Page



Main Playfield & Mini-Playfield - Metal Posts (Screws) and Nuts (Actual Size)	69
Main Playfield & Mini-Playfield - Hex Spacers (Actual Size)	70
Main Playfield & Mini-Playfield - Posts & Spacers (Actual Size)	71
Main Playfield & Mini-Playfield - Small Bayonet Type Bulbs & Sockets (Actual Size)	72
Main Playfield & Mini-Playfield - Large Bayonet Type Bulb and Sockets (Actual Size)	73
Main Playfield & Mini-Playfield - Wedge Base Bulbs and Sockets (Actual Size).....	74
Chapter 2, Drawings for Major Assemblies & Ramps (The Blue Pages)	75-98
▷ Overview	75
Ball Shooter (Plunger) Assembly, 500-6146-00-04	(Top) 76
Autoplunger Arm Weld Assembly, 500-6091-0 with ...Coil Assembly, 500-6092-06	(Bot) 76
5-Ball Trough Assembly, 500-6318-15 and Associated Parts:	77
Flipper (Left) Assembly, 500-6543-12 and Associated Parts:.....	78
Flipper (Right) Assembly, 500-6543-02 and Associated Parts:.....	79
Flipper (Mini-Playfield, Left) Assembly, 500-6543-79 and Associated Parts:.....	80
Flipper (Mini-Playfield, Right) Assembly, 500-6543-66 and Associated Parts:	81
Flipper (Mid. Playfield, Upr. Right) Assembly, 500-6543-24 and Associated Parts:.....	82
Turbo (Pop) Bumper Top Assy., 515-6459-01 (Qty. 3).....	(Top) 83
Turbo (Pop) Bumper Bottom Assy., 515-6459-04 (Qty. 3)	(Mid) 83
Turbo (Pop) Bumper Switch Assy., 515-6459-03 (Qty. 3) and Associated Parts:.....	(Bot) 83
Homer Head Actuator (Upr. Rt. Flipper Style) Assembly, 500-6543-21	84
Homer Head Assembly Individual Parts Only	85
Slingshot Assemblies, 500-5849-00 (Qty. 2).....	(Top) 86
30° Eject Assembly, 500-6511-11 and Associated Parts:.....	(Bot) 86
VUK (Vertical Up-Kicker, Right Style) Assembly, 500-6659-00	(Top) 87
VUK (Vertical Up-Kicker, Right Style) Assembly, 500-6660-00	(Bot) 87
3-Bank Drop Target Assembly, 500-6577-33.....	88-89
Bart & Skateboard on Rail Individual Parts Only.....	90
Main Playfield - Left & Right Plastic Ramps Individual Parts Only.....	91
Main Playfield & Mini-Playfield - Ramps Overview	92
30° Eject Assembly, 500-6661-00	(Top) 93
//////2nd LEVEL MINI-PLAYFIELD (BELOW)//////	
Garage Door Individual Parts Only.....	(Bot) 93
General Individual Parts Below Only.....	(Top) 94
//////2nd LEVEL MINI-PLAYFIELD (ABOVE)//////	
General Individual Parts Above Only	(Bot) 94
Couch Ball-Lock Individual Parts Only.....	95
TV (Color Dot Display) & LED (Mode Signifier) Individual Parts Only	96
Left Plastic Ramp & Plastic Trough Ramp Individual Parts Only.....	97
▷ UK ONLY OPTIONAL: Ball Deflector Assemblies, 500-5788-02 (Qty. 2)	(Top) 98
▷ UK ONLY OPTIONAL: Up/Down Post Assembly, 500-6293-00	(Bot) 98

SECTION 5 **99-148**

▷ Schematics & Troubleshooting Table of Contents (detailed outline of this section).....	99
▷ Coils Detailed Chart Table	100
Chapter 1, Backbox Wiring (The Yellow Pages)	101-102
Chapter 2, Playfield Wiring (The Yellow Pages)	103-106
Chapter 3, Cabinet Wiring (The Yellow Pages)	107-108
Chapter 4, Printed Circuit Boards (PCBs) (The Yellow Pages).....	109-144

APPENDIXES A-J **A1-J1**

▷ Appendixes A-J Table of Contents (outline of this section).....	after 144
▷ Appendixes A-J	A1-J1
Plastic Part Color Chart.....	(Bottom) H1 + (Top) I1
Glossary of Terms	Last Page
Limited Warranty, Cautions, Warnings & Notices.....	Last Page
▶ Switch Matrix Grid & Dedicated Switches ▶ Lamp Matrix Grid.....	Inside Back



After Set-Up

Pinball Game Set-Up Procedures

...after reading the Pinball Game Set-Up Instruction Sheet (SPI Part N^o 755-5310-00) included with your New Pinball Game, continue with the below procedures:

With the Back Glass Removed:

1. Check all connectors in the Backbox for loose wire terminations. Reseat any loose wire by pushing in on the terminal. **Push on all connectors** plugged into the CPU/Sound Board, I/O Power Driver Board, and the Display Power Bd. to check that they are properly seated. Ensure Fluorescent Light Tube is seated correctly. Check that all fuses are seated properly. **Close and lock the Backbox and secure its' keys back inside the Coin Door.**

With the Playfield Glass Removed:

2. Make sure the proper amount of pinballs were installed (*Amount of balls are always specified on decal attached to the lock down assembly and at the top of the inside cover*).

3. Remove all shipping tie downs, shipping blocks, packing foam, shipping instruction pages, etc. (if any) from the game. **READ ALL PRINTED INFORMATION!** Shipping instructions, labels and/or decals describe warnings, cautions, and/or important information specific to the game. **SAVE ALL PRINTED INFORMATION.**

4. Raise the playfield and support it, by lifting the **Prop Rod** (*located on the left, inside the cabinet*). The end of the Prop Rod should be placed into the hole under playfield. See the illustration "**Easy Access Service System - 3 Positions**" on Page 4.

5. Visually inspect all cabinet cables and connector terminations; ensure no wires or cables are pinched and that cable harnesses are not pulled tight.

6. Lower the playfield and ensure game is **level side-to-side** by adjusting Leg Levelers, if required. See the illustration "**Leg Leveler Adjustment**" on Page 4. Start with the Leg Levelers turned all the way in (1.25" from floor to bottom of leg), depending on the condition of the floor, adjust the Leg Levelers as required until the **game pitch is 6.5°**, determined by the Bubble Level.

USE THE BUBBLE LEVEL ON THE WOOD RAIL (LOWER RIGHT) TO DETERMINE IF LEVEL IS ACHIEVED. BUBBLE SHOULD APPEAR BETWEEN THE 2 BLACK LINES. SEE PAGE 4 FOR AN ILLUSTRATION.

The playfield incline affects difficulty of play. Use the recommended incline; Game difficulty is best varied using game adjustments.

With the Coin Door Open:

7. If desired, perform any self tests at this time (*see Section 3, Chapter 1, Portals™ Service Menu Introduction, and Chapter 2, GO TO DIAGNOSTICS MENU, for instructions on how to enter "Begin Play Test" and "Game Name Test" Menus to test components on the game*).

8. If desired, adjust **Game Pricing, Standard and/or Custom** (*see Section 3, Chapter 4, GO TO ADJUSTMENTS MENU and Section 3, Chapter 5, GO TO INSTALS MENU to adjust Game Difficulty, 3- or 5-Ball Play, Home or Tournament Settings, Novelty, Add-A-Ball, etc.*).

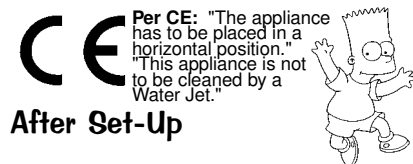

After Set-Up



PINBALL GAME SET-UP

CAUTION: At least 2 people are required to move and maneuver game. Use proper moving equipment & extreme care while handling. Pinball game is 200lbs (+/- 10). Refer to Game Manual for further Game Set-Up Procedures (Sec. 1, Chap. 1) and other important information!

TOOLS REQUIRED: 5/8" Socket Wrench & Utility Knife

1. Before opening box, lay the box flat on its side with "FRONT THIS SIDE ONLY" facing the floor.

2. Slide game out using the **Black Nylon Strapping** as a handle.

3. Remove the **Four (4) Identical Legs with Levelers** from the cabinet and set aside. (**SAVE!** all packing materials and information sheets related to this pinball until Set-Up is complete.)

4. At this point **DO NOT CUT STRAPPING!** (You want to keep the Backbox secured in the down position). Loosen and remove the 4 Leg Bolts (Use 5/8" Socket Wrench) and set aside.

5. Lift game into an **UPRIGHT POSITION** (Coin Door Facing Up).

6. Install **FRONT LEGS** using the bolts removed from **Step 4**. Secure tightly. **Take care not to scratch the Back**. **Finish on any of the Legs.**

7. Carefully set the game down on the **FRONT LEGS**. Care should be taken. Game is heavy; two (2) people are recommended for this and the following step.

8. Using supports or two (2) people, prop the rear of the cabinet up and install **REAR LEGS**. Secure tightly.

9. **CUT BLACK NYLON STRAPPING.** CAUTION: Strapping will SNAP protect your eyes! Use extreme care when using a utility knife or scissors.

10. Lift the Backbox into the **UPRIGHT POSITION** (Ensure the cables do not get pinched).

11. After the **BACKBOX** is in the **UPRIGHT POSITION**, locate the **SPRIG HEX KEY**. While inserted, rotate **KEY** with a 3/4 turn until latched & locked.

12. The next step you will remove the **PLAYFIELD GLASS & BACK GLASS** to access the inside of the cabinet & Backbox.

13. Open the Coin Door and pull the **YELLOW HANDLE** to the **LEFT** and at the same time pull up on the **FRONT TOP MOLDING** and remove. The **GLASS** can now be pulled out downwards and removed. **TAKE CARE** while moving; set glass on a safe surface.

14. Through the open **Coin Door** remove the **RETAINING RING** at the rear of the **CASH BOX** and open. Remove the **PINBALLS** & the **PLUMB BOB** from the **SPARE PARTS BAG**. (*Save the other spare parts in cabinet*). Install the **PINBALLS** by placing them on the playfield so they can roll into the **Outsole Ball Trough**.

15. Install the **PLUMB BOB** on the **Hanger Wire** and tighten the **Thumb Screw**. Loosening the **Thumb Screw** & lowering or raising the **PLUMB BOB** makes the Games **Tilt Function** more or less sensitive.

Remove the **PINBALL GAME MANUAL** (stapled to side of the left end of the cabinet). Review **Section 1, Chapter 1**, which describes how to tilt the playfield to access the **Plumb Bob** Assembly. The manual gives you all the important information you need to prepare for first service and other important information (such as Parts, Diagnostics, Schematics and more...).

NOTE: KEYS are tied to the **Shooter Rod** (if equipped) or tied to the **Playfield Glass** (if equipped with **Auto Plunger Button**). Remove **Shooter Rod** & **Auto Plunger Button** the other set is used to unlock the **Back Glass** to gain access to the **White Star Board System**.

ALWAYS STORE THE MANUAL & INFORMATION SHEETS INSIDE THE CABINET WHEN NOT USING.

1-800-842-6372
SPI Part N^o 755-5310-00

Pinball Game Set-Up Future Reference

Open up the Printable Version in both 8-1/2 X 11 & 11 X 17.

CAUTION: At least 2 people are required to move and maneuver game.

Use proper moving equipment & extreme care while handling. Pinball game is 260lbs (+/- 10).

Refer to Game Manual for further Game Set-Up Procedures (Sec. 1, Chp. 1) and other important information!

TOOLS REQUIRED: 5/8" Socket Wrench & Utility Knife

Sec. 1: After Set-Up



1. Before opening box, lay the box flat on its side with "TRUCK THIS SIDE ONLY" facing the floor.



2. Slide game out using the **Black Nylon Strapping** as a handle.

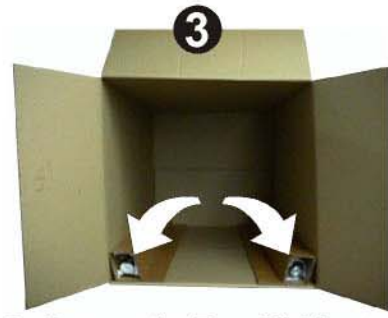

3. Remove the **Four (4) Identical Legs with Levelers** from the carton and set aside. (**SAVE!** all packing materials and information sheets related to this pinball until Set-Up is complete.)

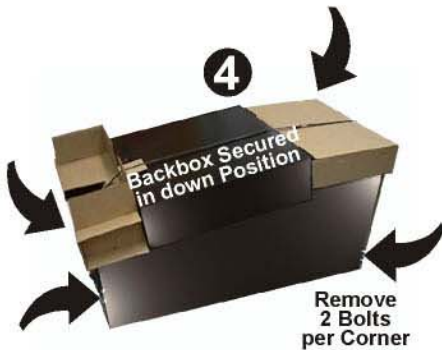

4. At this point **DO NOT CUT STRAPPING** (You want to keep the Backbox secured in the down position). Loosen and remove the 8 Leg Bolts (use 5/8" Socket Wrench) and set aside.



5. Lift game into an **UPRIGHT POSITION** (Coin Door Facing Up).



6. Install **FRONT LEGS** using the bolts removed from **Step 4**. Secure tightly. **Take care not to scratch the Black Finish on any of the Legs.**



7. Carefully set the game down on the **FRONT LEGS**. Care should be taken...Game is heavy, two (2) people are recommended for this and the following step.



8. Using supports or two (2) people, prop the rear of the cabinet up and install **REAR LEGS**. Secure tightly.



9. Cut **BLACK NYLON STRAPPING**. **CAUTION:** Strapping will **SNAP**, protect your eyes! Use extreme care when using a utility knife or scissors.



Pinball Game Set-Up Future Reference Continued

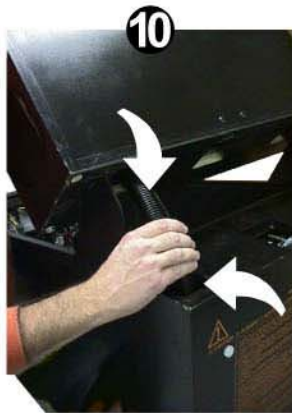

10. Lift the Backbox into the **UPRIGHT POSITION** (Ensure the cables do not get pinched).



11. After the **BACKBOX** is in the **UPRIGHT POSITION**, locate the **5/16" HEX KEY**. While inserted, rotate **KEY** with a **3/4** turn until latched & locked.



12. The next step you will remove the **PLAYFIELD GLASS & BACK GLASS** to access the inside of the cabinet & Backbox.

NOTE: KEYS are tied to the Shooter Rod* (if equipped) or taped to the Playfield Glass (if equipped with Auto Plunger Button). Remove keys. One (1) set of keys opens the Coin Door, the other set is used to unlock the Back Glass to gain access to the White Star Board System.

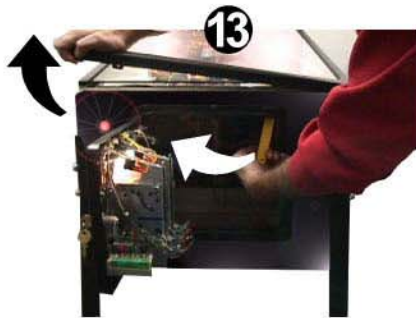

13. Open the Coin Door and pull the **YELLOW HANDLE** to the **LEFT** and at the same time pull up on the **FRONT TOP MOLDING** and remove. The **GLASS** can now be pulled out towards you and removed. **TAKE CARE** while moving; set glass on a safe surface.



14. Through the open **Coin Door**, remove the **RETAINING RING** at the rear of the **CASH BOX** and open. Remove the **PINBALLS** & the **PLUMB BOB** from the **SPARE PARTS BAG**. (Save the other spare parts in cabinet). Install the **PINBALLS** by placing them on the playfield so they can roll into the **Outhole Ball Trough**.

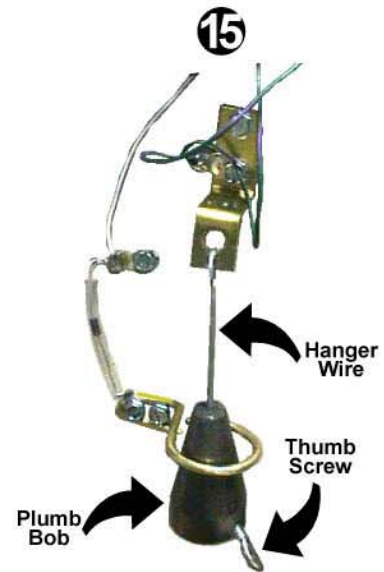

15. Install the **PLUMB BOB** on the **Hanger Wire** & tighten the **Thumb Screw**. Loosening the **Thumb Screw** & lowering or raising the **PLUMB BOB** makes the **Games Tilt Function** more or less sensitive.



STERN
PINBALL, INC.
1-800-542-5377

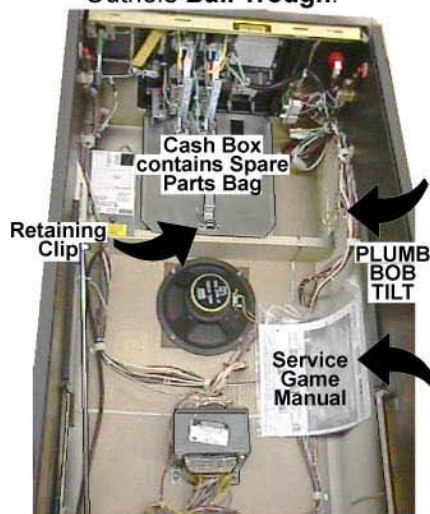

Remove the **PINBALL GAME MANUAL** (stapled to side of the left wall of the cabinet). Review **Section 1, Chapter 1**, which describes how to lift the playfield to access the **Plumb Bob Tilt Assembly**. The manual gives you all the important information you need to prepare for final set-up and other important information (such as Parts, Diagnostics, Schematics and more...).

ALWAYS STORE THE MANUAL & INFORMATION SHEETS INSIDE THE CABINET WHEN NOT USING.



How to Secure the Backbox for Transporting

For more Backbox details & part numbers, see Section 4, Chapter 1, **Backbox Assembly**, Pages 60-61.

Sec. 1: After Set-Up

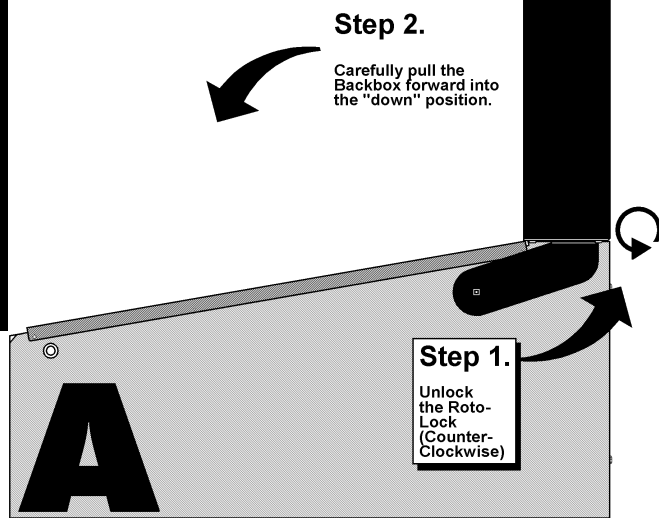

Step 3.

The top of the Backbox will rest on the Pinball Side Armor. Strap or tie down the Backbox to keep from "bouncing" during transport.

Ensure Cables do not bind, pinch or are being pulled tight. Hand-Feed out with Backbox so Cables are not tight.

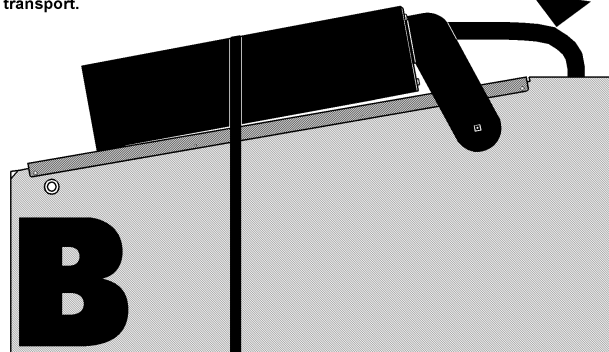

Leg Leveler Adjustment

Attach the four (4) Leg Assemblies to cabinet corners with the eight (8) leg bolts provided .

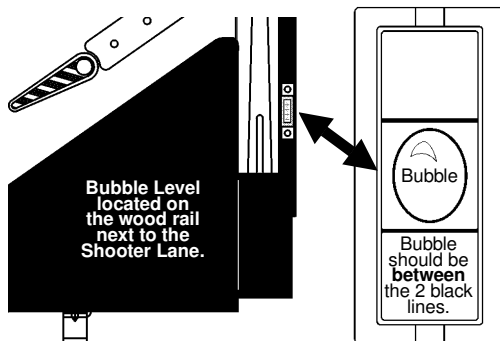

Start adjustment with the leg levelers *turned all the way in*.

View the *bubble* in the level provided on the right side wood rail.

Adjust the front or rear levelers as necessary to cause the bubble to float between the two (2) black lines.

Use a pinball to roll down the center of the playfield for side-to-side leveling.

YOUR PLAYFIELD PITCH IS NOW AT 6.5° AS REQUIRED FOR PROPER GAME PLAY!

Note: For custom adjustment greater than >6.5° can be achieved by turning out the rear leg leveler(s), however, it is not recommended.

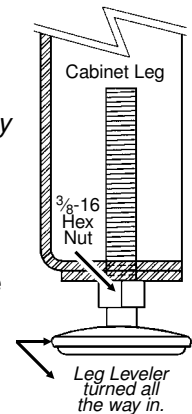

Easy Access Service System - 3 Positions

With the front molding & glass removed, carefully lift the playfield (*take care when using the Bottom Arch to hoist*).

Positions 1 & 2

When lifted high enough, the **Playfield Support Slide Brackets** (Fig. 1A) can be seen & can clear the cabinet front. At this time, pull the playfield toward the front of the cabinet, checking that the mechanical components clear the cabinet front, then rest the playfield on the **Playfield Support Slide Brackets** at the front channel of cabinet (Fig. 1C); Or, the **Prop Rod** (located on the right inside of cabinet) can be used by positioning the **Prop Rod** end into the receiving playfield hole (Fig. 1B).

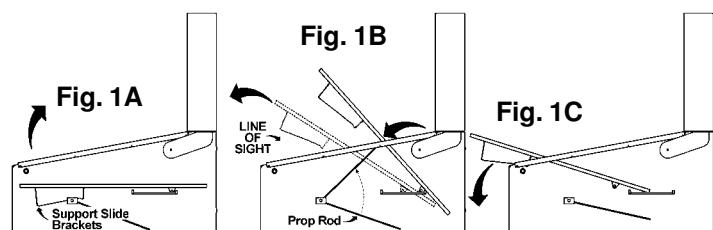

Position 3

With the playfield at rest, hold the sides & pull toward the front of the cabinet (approx. 6" to 8"), until resistance is felt from **Edge Slide Brackets** stopping against the **Slide & Pivot Support Brackets** located on either side of the cabinet (Fig. 2A). At this time, swivel the playfield toward the Backbox, then rest on the top edge (Fig. 2B & 2C).

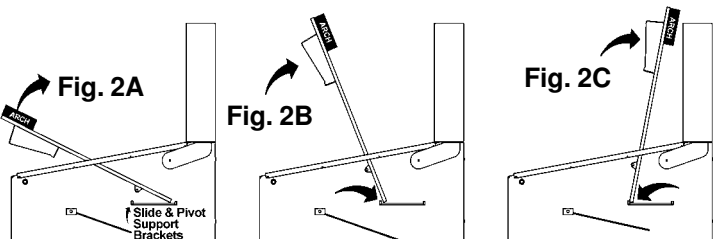

Game Operation & Features

Start of Game Features

Starting a Normal Game

Insert coin(s). The game generates a sound for the first coin & for each subsequent coin with the display indicating the number of credits posted. Press the **Start Button** and a start-up sound is produced, and the posted credits are reduced by one. Subsequent players can be added (**up to 4 can play!**) by pressing the **Start Button** before the end of ball 1 (*with sufficient credit in the game*).

The display now indicates the player or # of players selected from the total depressions of the **Start Button**. The display indicates the ball in play, and a ball is served to the *Shooter Lane*. An introduction is shown followed by Skill Shot Graphics and/or instructions. Pressing the **Start Button** after ball 1 of any player will start a new game (*if credits are available*), **but only** if the **Start Button** is depressed for 2-3 seconds. This delay is to avoid accidental "re-starts" of a game. **Note:** *Any partial credit remaining during game play after the end of ball 1, or power down, will be eliminated.*

Starting Team Play (Doubles!)

Team Play is a four (4) player game. The totals for Players 1/3 (Team 1) & Players 2/4 (Team 2) are displayed individually as well as the combined score for both teams. Team Play only works in a 4-Player game. In all other cases, the individual scores are shown.

Starting Tournament Play with ToPS™

This Pinball Game is **ToPS™ (Tournament Pinball System) Ready. Optional Tournament equipment & hardware (sold separately) is required.** Review **Section 3, Chp. 7, GO TO TOURNAMENT MENU**, for more info!

Unlike a "Normal Game", the Tournament Game is started by depressing the **Tournament Start Button** (*located on the Front Molding, if installed*). If adequate credit(s) are posted **and a Tournament is started** via **Portals™** (*select the "TOUR" Icon in the Main Menu*), the **Tournament Start Button** will flash. *Any adjustments or installs changed will not be in affect. Starting a Tournament Game defaults to preprogrammed Tournament Rules (e.g. No Extra Balls, Specials or Bonus Credits are awarded); however, starting a Normal Game after a Tournament Game will then revert back to any unique adjustments or installs performed previously. During and End of Game Features operate in the same manner (differences in adjustment defaults are present).*

During Game Features

Feature Mode & Combination Shots

Features are lit on the playfield and started by completing *certain shots (e.g. completion of Target Banks, Orbit(s), Ramp(s) and/or any combination of the shots)*.

Multiball

Multiball is started after completion of certain features (*amount of balls used depends on game rules*).

Replay Feature

Replay awards are given as the player exceeds a High Score Level during game play. This can be adjusted with **Standard Adj. 3, Replay Award** (Default = **CREDIT**). Players exceeding the High Score Levels can receive: **CREDIT**, **EXTRA BALL**, or **SPECIAL**. Adjust to **NONE** if a replay award is not desired.

End of Game Features

Game Endings

When all player(s) have played all balls (including any Extra Balls), the game ends. If power is interrupted during the course of a game, it will end that game (**see Starting a Normal Game**). Closure of the Plumb Bob Tilt Switch according to the number of tilts set, **Standard Adj. 15, Tilt Warnings** (Default = **01**) or prolonged closure, will end the current Ball-In-Play. Closure of the Slam Tilt Switch on the Coin Door ends the current game(s).

Match Feature

At the end of each ball, earned bonuses are collected. At the end of the last ball of a game (including any extra balls, if applicable), earned bonuses are collected, then the system produces a random 2-digit number (a multiple of 10; 00 to 90). Matching the last 2 digits of the player's score with this number awards a credit. In **Std. Adj. 13, Match Percentage** (Default = **8%**) can be changed from 0-10%. Changing the percentage to **0% displays** the "Match Animation" at the end of the game, however, will never match nor award anything. Changing this adjustment to **OFF** will **not display** the "Match Animation" nor award anything.

Entering Initials/Name

If player achieved a new *High Score* in a game or achieved a *Special Feature (if given)* the player may enter 3 Initials. In **Std. Adj. 29, High Score Initials** (Default = **3 Initials**) can also be changed to **10-Letter Name**. Use the **Flipper Buttons** to choose a letter or character as seen on the Dot Display. Hitting the **Start Button** locks in the letter or character and proceeds to the next letter. The game then proceeds into the **Game-Over Mode** and then to the **Attract Mode**.

Note: **Standard Adj. 31, Custom Message** (Default = **ON**) can be displayed during the **Attract Mode**; enter letters in the same fashion.

For more details on Adjustments, see **Sec. 3, Chp. 4**.

Continued Next Page.

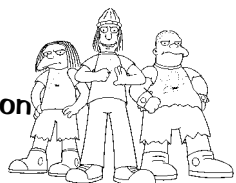

Auto Percentaging

This game is equipped with Auto Percentaging, **Standard Adj. 01, Replay Type** (Default = **AUTO**, adjustable). The *Replay Percent* is automatically adjusted, **Standard Adj. 02, Replay Percentage**, or you can set a *Fixed Replay Score*. Four levels may be selected. Adjustments allow awarding of a "CREDIT" (or your setting) as each level is exceeded. This can be adjusted with, **Standard Adj. 03, Replay Award** (Default = **CREDIT**). With the **Autopercentage Feature**, if the actual replay percentage is higher or lower than that desired, the game will automatically adjust for the new recommended percentage score(s). You may choose to make a different "score-to-beat" adjustment; this is done by utilizing **Standard Adj. 04, Replay Levels**. For more details with **Adjustments**, see *Section 3, Chapter 4, GO TO ADJUSTMENTS MENU*; also, see *Section 3, Chapter 5, GO TO INSTALLS MENU* for further customization of your Pinball Game.

Sec. 2: Game Op.

Instruction Card

Below is a **COPY** of the Game Instruction Card (SPI N^o: 755-5177-00 USA) which is included with every game. If your card is lost or damaged, simply **COPY** this page and *cut out* the Instruction Card as a *temporary replacement* until a *new card* is ordered.

(Hint: **COPY & CUT** along the dotted line and fold in the center to keep the "COPY" sturdy.)

COPY & CUT

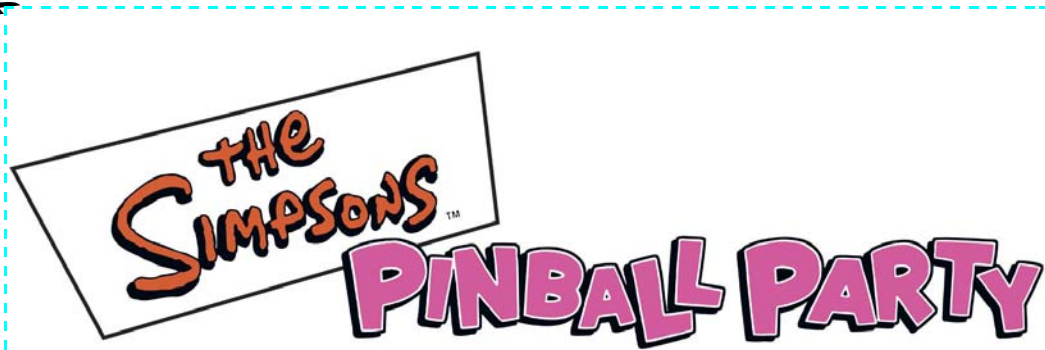

For more detailed game rules, visit our website @ www.SternPinball.com and click on the "The Simpsons™ Pinball Party" or "Game Archive" Pop Bumper Link.

FOLD HERE

Click on card to open the Instruction Card for printing.

OBJECT: Help the citizens of Springfield party like there's no tomorrow!
GET DUFFED!: Shoot Moe's (Right Ramp) to light Extra Ball and the Treehouse of Horror.

LIVING ROOM: Shoot into the Garage or the Treehouse (Left Ramp) to enter the Upper Playfield.

ITCHY & SCRATCHY: Shoot past Drop Targets for Itchy & Scratchy Multiball.

OTTO'S BUS TOURS: Shoot Otto to enable shots for **double scoring**.

COMIC BOOK GUY: Hit CBG to light Hurry-Ups. Collect them before they go away!

DAREDEVIL BART: Hit Captive Ball to light playfield shots for big points!

TV: Shoot under the TV to start modes.

MULTIBALL: Lock balls in the couch to start Multiball. In Multiball, shoot couch for Super Jackpot.

TIMER: All timed features use the same timer.
Starting any feature resets timer for all features!



The Simpsons TM & © Twentieth Century Fox Film Corporation. All Rights Reserved. SPI PART N^o: 755-5177-00 USA





Section 3 Service Menu System Table of Contents



Service Switch Set (Red, Green & Black Buttons) Access & Use 8
 ♦ Function 1, Volume Menu / Function 2, Service Credits Menu / Function 3, Portals™ Service Menu 8

Chapter 1, Portals™ Service Menu Introduction 9

How to Use This Section 9

Portals™ Service Menu Icon Tree for The Simpsons™ Pinball Party Pinball 10-11
 ♦ Example 12-13

QUIT THIS SESSION (Exiting the Portals™ Service Menu) & Problem / Solution Table 14

Chapter 2, Go To Diagnostics Menu (Overview) 15

GO TO DIAGNOSTICS MENU 15

- **Go To Switch Menu** ■■ **Switch Test** ■■ **Active Switch Test** ■■ **Dedicated Switch Test** 16
 - ♦ Switch Matrix Grid & Dedicated Switches
 - ♦ Switch Matrix Grid Locations, Typical Switch Wiring & Schematic, Dedicated Switch Schematic 17
- **Go To Coil Menu** ■■ **Single Coil Test** ■■ **Cycling Coil Test** 18
 - ♦ Partial Coils Detailed Chart ...
 - ♦ Coil & Flash Lamp Locations, Typical Coil Wiring, Bulb Types used for Flash Lamps 19
 - ♦ Coils Detailed Chart Table 20
 - ♦ Backbox I/O Power Driver Board Detailed Wiring Diagram 21
- **Go To Lamp Menu** ■■ **Single Lamp Test** ■■ **Test All Lamps** ■■ **Row & Column Lamp Tests** 22
 - ♦ Lamp Matrix Grid
 - ♦ Lamp Matrix Grid Locations, Typical Lamp Wiring & Schematic, Bulb Types used for Lamps 23
- **Test Flash Lamps** ■ **Clear Ball Trough** 24
- **Technician Alerts (Switch Detection and Pinball Detection)** 24-25
- **Service Phone #** ■ **Begin Play Test** ■ **Fire Knocker** 25
- **Sound / Speaker Test (Speaker Phase Testing)** 25-26
- **Begin Burn In** ■ **Dot Matrix Test (Dot Matrix Display Explained)** 26
- **LED Test** 27-28
- **Go To Fuse Table (with Example)** 29

BACKBOX LAYOUT LOCATIONS: Fuses, Bridges, Relays & ROMs 30

- **Dr. Pinball** ■■ **Coil Flow Chart** ■■ **Switch Flow Chart** ■■ **Lamp Flow Chart** 31

Chapter 3, Go To Audits Menu (Overview) 33

♦ **EARNINGS & STANDARD AUDIT TABLES** 32

GO TO AUDITS MENU 33

- **Earnings Audits (01-14)** 33
- **Standard Audits (01-67)** 34-35
- **Feature Audits (01-165)** 36
- **Go To Printer Menu** ■■ **Quick Printout** ■■ **Full Printout** ■■ **Reset Printer** 37

Chapter 4, Go To Adjustments Menu (Overview) 39

♦ **STANDARD & FEATURE ADJUSTMENT TABLES** 38

GO TO ADJUSTMENTS MENU 39

- **Standard Adjustments (01-48)** 39-43
- **Feature Adjustments (01-35)** 44-45
- **Custom Message (Direct Access to Adjustment 31)** 46

Chapter 5, Go To Installs Menu (Overview) 47

GO TO INSTALLS MENU 47

- **Install Extra Easy** ■ **Install Easy** 47
- **Install Normal** ■ **Install Hard** ■ **Install Extra Hard** ■ **Install 3-Ball** ■ **Install 5-Ball**
- **\$.50 Tournament** ■ **Free Play Tournament** ■ **Install Home Play** 48
- **Film Star Reset** ■ **Install Novelty** ■ **Install Add-A-Ball** ■ **Install Factory** 49
- ♦ **Overview of Standard Adjustment Changes and ... Feature Adjustment Changes with selection of these Installs** 49-50

Chapter 6, Go To Reset Menu (Overview) 51

GO TO RESET MENU 51

- **Reset Coin Audits** ■ **Reset Game Audits** ■ **Reset High Scores** ■ **Reset Credits** ■ **Factory Reset** 51
- ♦ **Example** 52

Chapter 7, Go To Tournament Menu 53

GO TO TOURNAMENT MENU (OPTIONAL USE ONLY) 53

- ♦ **TOURNAMENT ADJUSTMENT TABLES & TOURNAMENT AUDIT TABLE** 54
- **Tournament Adjustments (01-10)** 55
- **Start Tournament** ■ **Stop Tournament** ■ **Tournament Prizes** ■ **Tournament Audits (01-12)** 56
- **Tournament Audits Continued** ■ **Sign Messages A-B (Tournie Adj. 11-12)** 57

Sec. 3: ...Menu Intro.



Service Switch Set (Red, Green & Black Buttons) Access & Use

The **Service Switch Set** provides access for **three (3) functions** available for your use. They are **Volume Menu**, **Service Credits Menu** and **Portals™ Service Menu**. All are accessed separately depending on which colored button (**Red**, **Green** or **Black**) is **pushed first**.

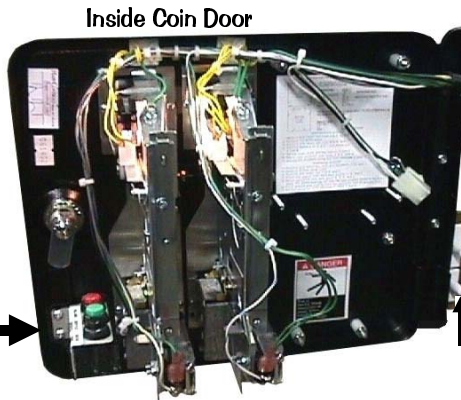

If Coil & Flashlamp Testing, the Playfield Power Interlock Switch must be pulled out.

The Memory Protect Switch is disabled when the Coin Door is open (required for any changes...)

To access any of these **three (3) functions** you must first open the **Coin Door** (see pictorial above) with the Game in the **Attract Mode** (not already in any Function or Menu stated below).

Pushing Red 1st



Function 1, Volume Menu

Pushing the **Red Button (VOLUME / LEFT)** first, enters the **Volume Menu**. While in this Mode, to **DECREASE** the volume, hold down or depress the **Red "LEFT" Button** until desired the volume is achieved; to **INCREASE** the volume, hold down or depress the **Green "RIGHT" Button** until the desired volume is achieved.

Note: Pushing the **Left or Right Flipper Buttons** operates the same as the **Red or Green Buttons** of the Service Switch Set, while in this Volume Mode.

Set between **0** and **31**; **15** is the **Factory Default**. Once your adjustments are made, this menu will **automatically exit** a few seconds after the last button depression.

Pushing Green 1st

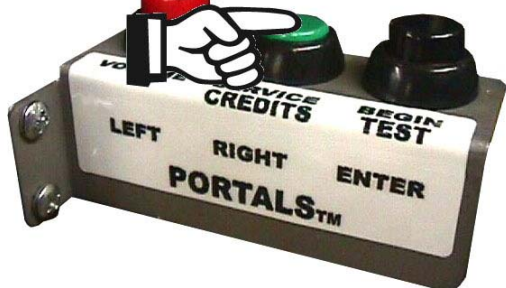

Function 2, Service Credits Menu

Pushing the **Green Button (SERVICE CREDITS / RIGHT)** first, adds **Service Credits** (will not affect your audits as "paid" credits). This is useful for the technician to test games in regular play without affecting the game audits. Each depression adds **1 credit**; up to **50 credits** can be applied. **Adj. 16, Credit Limit**, determines this, however, it can be changed from 04-50; for details see **Chapter 4 of this Section 3**. Once your credits are added, this menu will **automatically exit** a few seconds after the last button depression.

Note: This function is disabled if **Adjustment 30, Free Play**, is set to **YES**. The **Service Credits** are limited to the **Credit Limit** in addition to any paid credits present in the game (e.g. If the **Credit Limit** is 30, and there are 8 paid credits present, only 22 **Service Credits** can be applied).

open Adjustments

Pushing Black 1st



Function 3, Portals™ Service Menu

Pushing the **Black Button (BEGIN TEST / ENTER)** first, enters the **Portals™ Service Menu**. Once in, navigate through all menus depressing the **Red "LEFT"** or **Green "RIGHT"** Buttons.

Note: Pushing the **Left or Right Flipper Buttons** operates the same as the **Red or Green Buttons** of the Service Switch Set, while in this Service Mode.

Select or activate the **Icon** chosen (the **Icon** will be "flashing") by pushing down or depressing the **Black "ENTER"** Button.

Note: Pushing the **Start Button** operates the same as the **Black Button** of the Service Switch Set, while in this Service Mode.

Please read the remainder of this Chapter for more information on the **Portals™ Service Menu**. The remaining six (6) Chapters of this Section explains all **Icons & Menus** in detail. **Read! Read! Read!**



Sec. 3: ...Menu Intro.

Portals™ Service Menu Introduction

Important: The *Dual Switch Bracket* holds the *Playfield Power Interlock & Memory Protect Switches*. It is located just inside the Coin Door frame (see pictorial of the *Coin Door* on the previous page). The Button Switch at the top is the *Playfield Power Interlock Switch*. It must be pulled out for electro-mechanical device testing or diagnostic purposes (this is required). If this button is pushed in, the *Playfield Power* is disabled while the *Coin Door* is **OPEN**. The Button Switch at the bottom is the *Memory Protect Switch*. It is enabled while the *Coin Door* is **CLOSED**; meaning any adjustment changes that are made **will not be written to memory**. If changing adjustments is required, ensure the *Coin Door* is **OPEN** to disable this switch, thus allowing for desired changes.

How to Use This Section

This section will cover all functions available in the **Portals™ Service Menu** in a *Step-By-Step* process. This section is divided into chapters which coincide with the **MAIN MENU**. The previous and following pages in this Chapter will instruct the operator on how to move through the Menus. It's simple, easy and fun to use!

To get into the **Service Menu Mode** review "**Function 3, Portals™ Service Menu**" on the previous page. After Power-Up, push down the **Black "BEGIN TEST" Button** to begin. Looking at the display you will momentarily see "**Service Menu**" with a *satellite flying from right to left pulling a banner "Portals©™"* followed by the **MAIN MENU**:

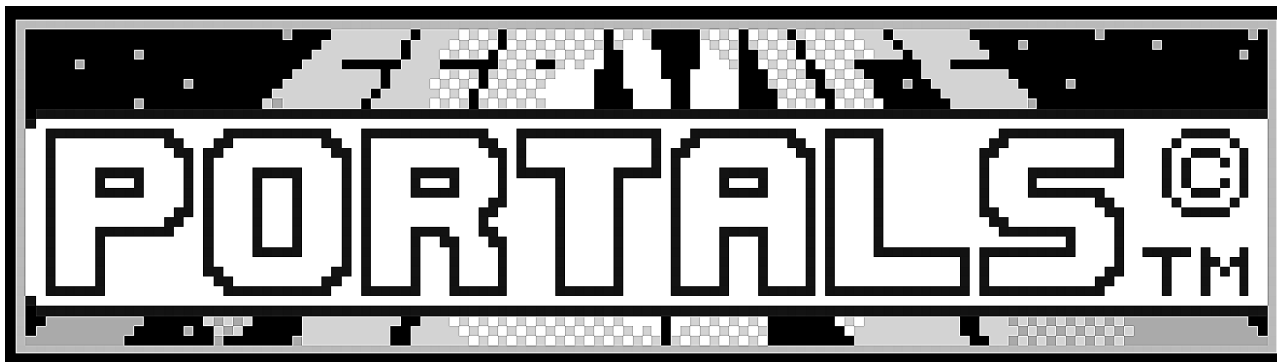

Use the **Red "LEFT" & Green "RIGHT" Buttons** (or **Left & Right Flipper Buttons**) to move the selected *Icon* left or right, and the **Black "ENTER" Button** (or **Start Button**) to activate the selected *Icon*. The use of the **Service Switch Set (Red, Green, & Black Buttons)** is required in **Switch Test** or **Active Switch Test**, as the **Start & Flipper Buttons** are a part of this test.

The **MAIN MENU** now appears with the "**DIAG**" *Icon* (**GO TO DIAGNOSTICS MENU**) flashing:



As the operator views the Menu Screen(s), the **MORE MORE** symbols indicates that there are more *Icons* to select in each direction. The *Icon* selected will blink. Pushing the **Black "ENTER" Button** (or **Start Button**) will select the *Icon* and the Menu Screen will change to the menu selected. Select the "**PREV**" *Icons* to move backwards through the menu levels. Select the "**QUIT**" *Icon* to completely exit the Service Mode.

View the **Portals™ Service Menu Icon Tree** on the next pages for a complete overview of all menus used in this system. The "**HELP**" *Icon* & "**?**" *Mini-Icon* provide explanation of **ICON** usage in the Menu where the "**HELP**" *Icon* or "**?**" *Mini-Icon* was selected. View **QUIT THIS SESSION (Exiting the Portals™ Service Menu)** at the end of this chapter (reference **Section 3, Chapter 1, Portals™ Service Menu Introduction**).

The **chapters** in this **section**, which coincide with the **MAIN MENU**, will also provide more detailed information. **Use both the manual and the display to help customize, troubleshoot and/or diagnose faults, if any.**



COIN DOOR IS OPEN
PLAYFIELD HIGH POWER
DISABLED BY
COIN DOOR INTERLOCK

* WHEN ENTERING THESE NOTED MENUS, YOU MUST PULL OUT the Power Interlock Switch for operation with the Coin Door open.

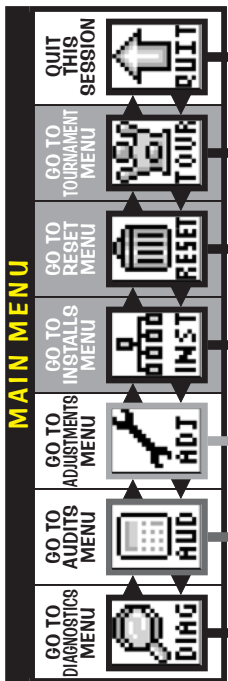

MAIN MENU

These **non-selectable** icons appear in the selected Menu only when there are **MORE** icons to the **LEFT** or to the **RIGHT** available for selection.



CONTINUED NEXT PAGE.

DIAGNOSTICS MENU

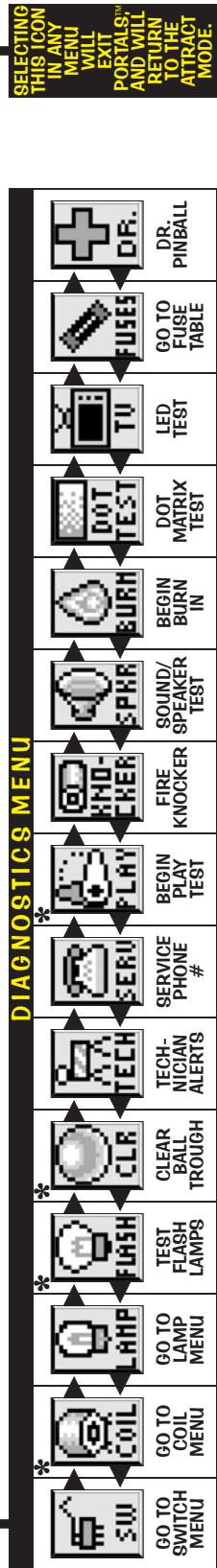

SELECTING THIS ICON IN ANY MENU WILL EXIT PORTALS™ AND WILL RETURN TO THE ATTRACT MODE.

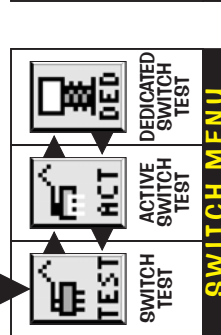
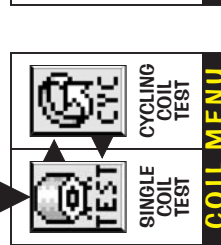
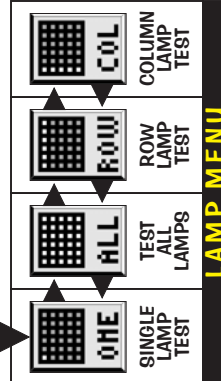
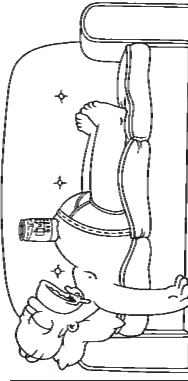

DR. PINBALL MENU

LAMP MENU

COIL MENU

SWITCH MENU

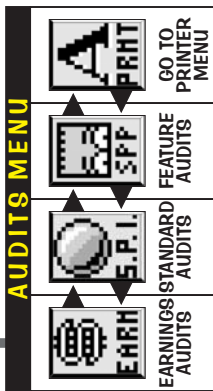

Explanation & usage of common Large & Mini-Icons used in various Menus & Sub-Menus:

Note: In Sub-Menu Tests or Displays, further action is required: select & activate the appropriate Mini-Icon(s).

- PREV** Return to the PREVIOUS Menu.
- QUIT** QUIT, exits & returns to the Attract Mode.
- HELP** View HELP Screens of the current Menu.
- END** END current coil selection to select a new coil for diagnosing in Dr. Pinball Menu.
- YES** Answer NO or YES for Flow Chart Menu questions in Dr. Pinball Menu.
- ORIG** View the schematic (DRAWING) of current display. Select while current switch, lamp or coil is viewed.
- DIR** RUN (or activate) selected test or coil.
- FILSE** PULSE coil.
- DECR** DECREMENT (-) or INCREMENT (+) displayed value or select previous/next.
- LEFT** Move LEFT or previous/next backwards/ forwards.
- RIGHT** Move RIGHT, select previous/next or move backwards/ forwards.

Note: If a new **MINI-ICON** is used for a specific function, select the "P" icon for more information.

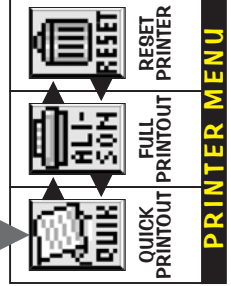
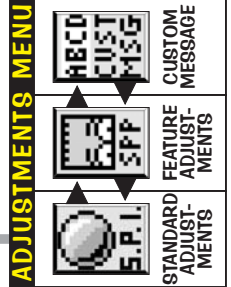

OPTIONAL PRINTING KIT (sold separately) IS REQUIRED FOR OPERATION OF THIS MENU.

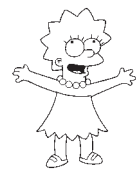

PINBALL PARTY Portals™ Service Menu Icon Tree Continued

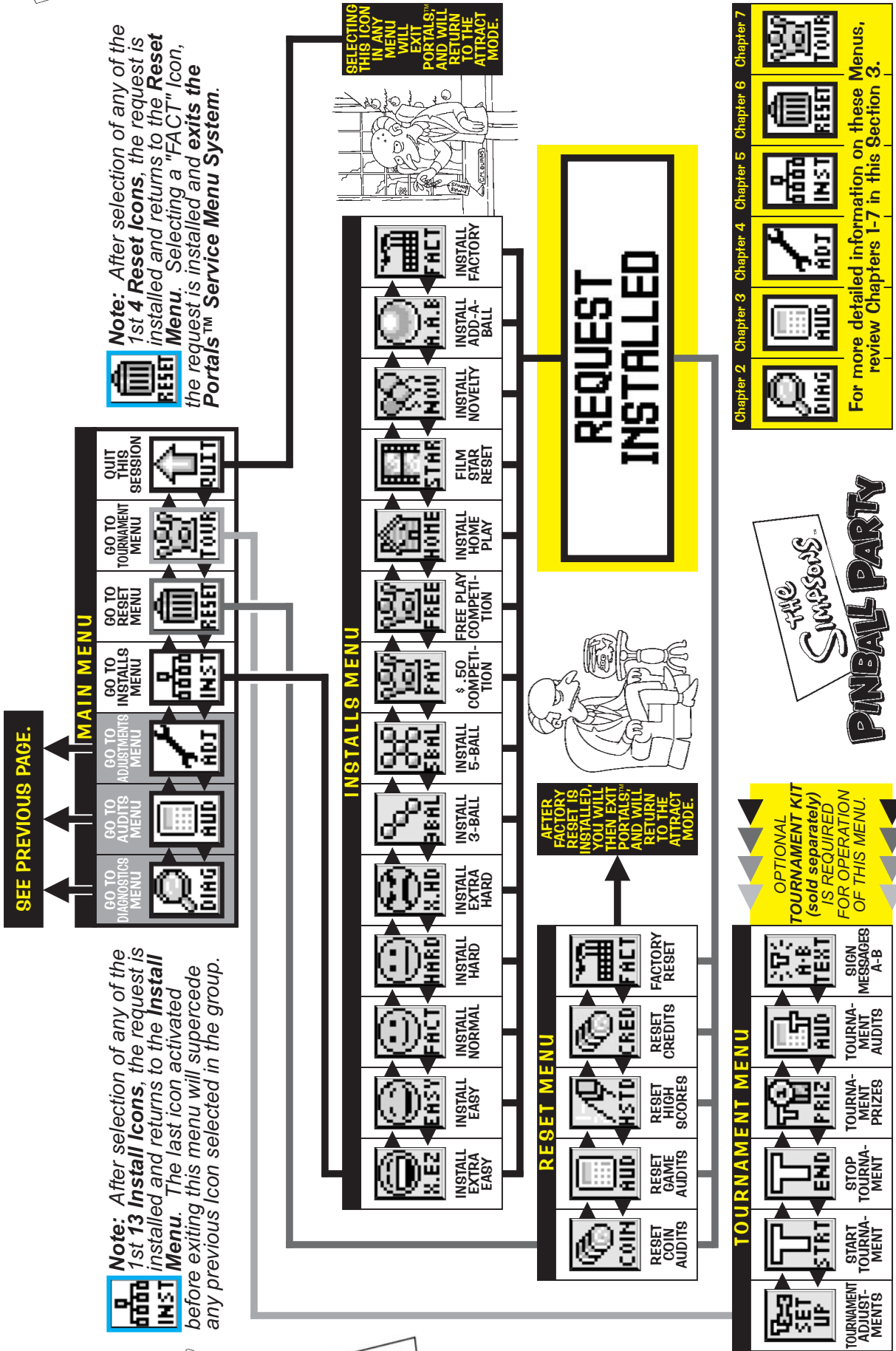

Sec. 3: ...Menu Intro.

Portals™ Service Menu Example

This example will demonstrate activation of *Icons* in the **DIAGNOSTICS MENU**. The example will show activation of the "SW" *Icon* (**GO TO SWITCH MENU**). In this menu, the switches can be tested individually and also all active switches can be tested. Use the same technique to access all the *Icons* in the **Portals™ Service Menu**. Follow **Portals™ Service Menu Icon Tree** on the previous pages as a guide to help navigate through the entire system (Also, go to the chapter in this manual explaining the icon(s) selected.).

If the display is in any other menu other than the **MAIN MENU**, use the **Red "LEFT" & Green "RIGHT" Buttons** to select the "PREV" *Icon* and press the **Black "ENTER" Button** to *activate* the **ICON** thus moving back to the previous menu. Do so until **MAIN MENU** appears.

Chapters 2 through 7 will cover all menu items within the **Portals™ Service Menu**. The *Icon* is shown preceding the text. Find the *Icon* in the **Portals™ Service Menu** by navigating with the **Red or Green Buttons**. Each chapter started is from the **MAIN MENU**. Within the chapter, and Sub-Menu will be covered sequentially with their explanation & function. If the operator "gets lost", select and *activate* the "PREV" *Icon* until the display indicates **MAIN MENU**. For more help on Button Usage, select & *activate* the "HELP" *Icon* or "?" *Mini-Icons*.

EXPLANATION & USAGE OF COMMON LARGE & MINI-ICONS USED IN VARIOUS MENUS & SUB-MENUS:

Select and activate to:



These non-selectable *Icons* appear in the selected *Menu* only when there are **MORE** *Icons* to the **LEFT** or to the **RIGHT** available for selection.



Select and activate to return to the **PREVIOUS** *Menu*.



Select and activate to **QUIT**, exits & returns to the **Attract Mode**.



Select and activate to view **HELP** Screens of the current *Menu**.



Move **LEFT** or **RIGHT**, select previous / next or move backwards / forwards.

DECREMENT (-) or **INCREMENT (+)** displayed value or select previous / next.

RUN (or activate) selected test or coil
PULSE coil.

DRAW View the schematic (**DRAW**ing) of current display. Select while current switch, lamp or coil is viewed.

* **Help Note:** An explanation of each *Mini-Icon* at that *menu level* will cycle continuously. To exit a display where no *Mini-Icons* are available for selection, pressing any button will exit the display.

Sec. 3: ...Menu Intro.

Example:

After entering **Portals™**, the **MAIN MENU** now appears with the "DIAG" *Icon* (**GO TO DIAGNOSTICS MENU**) flashing:

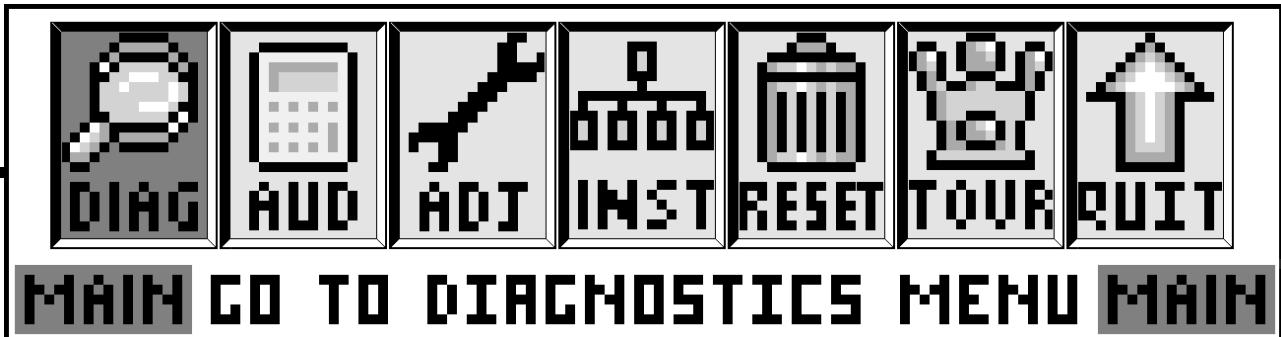

Press the **Black "ENTER" Button** to *activate* this **ICON**. The **DIAGNOSTICS MENU** now appears with the "SW" *Icon* (**GO TO SWITCH MENU**) flashing:

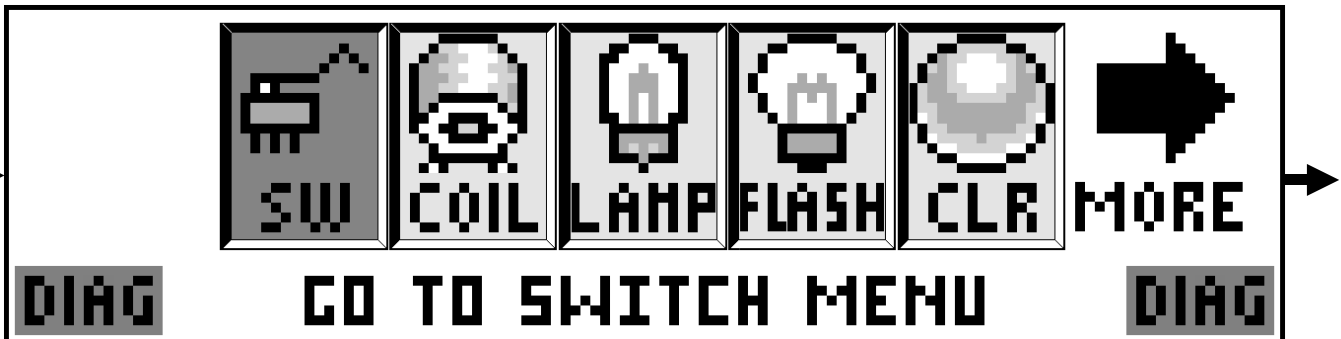

Press the **Black Button** to *activate* this **ICON**. The **SWITCH TEST MENU** now appears with the "TEST" *Icon* (**SWITCH TEST**) flashing:

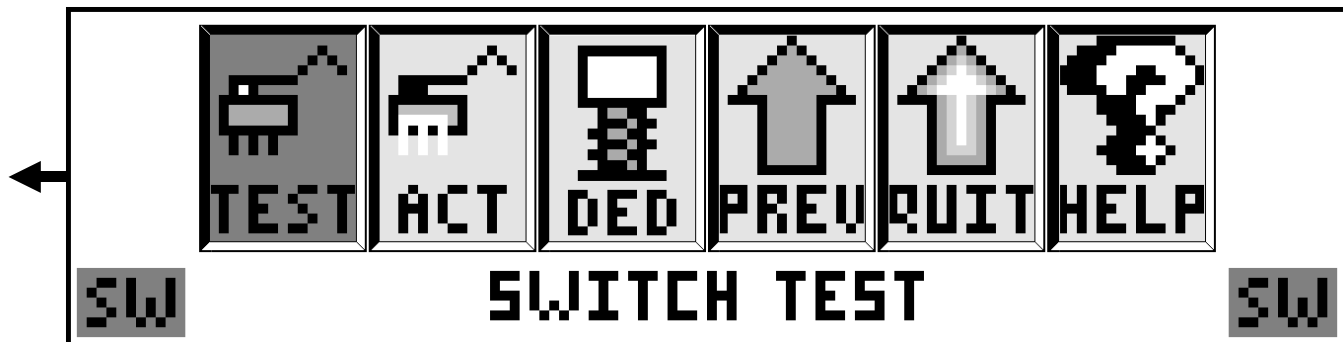

Press the **Black "ENTER" Button** to *activate* this icon. The **Switch Test Display** now appears.

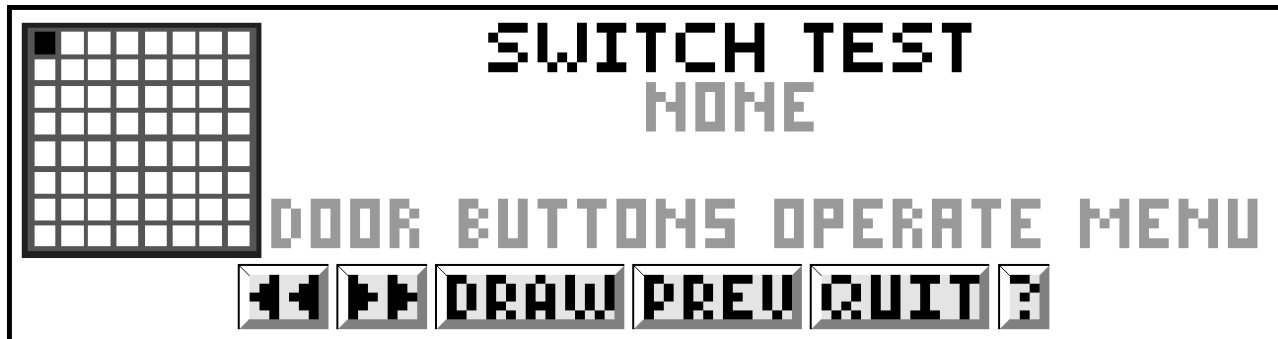

All switches can be tested one at a time. When possible, use a pinball to close any playfield switches; rolling the ball at Stand-Up Targets or over/under switches is suggested. Use finger for all non-playfield switches. As each switch is closed, the respective Switch Matrix Grid Position (1-64) will be lit.

To view the schematic for the switch selected, press either the **Red** or **Green Button** to select the "DRAW" *Mini-Icon*. Press the **Black Button** to *activate* this *Mini-Icon*; do so while the switch is momentarily closed. This will bring up the **Switch Schematic Display**. The display describes the switch in the Switch Matrix which includes the name of the switch, the Return (Row) Wire and the Drive (Column) Wire, drive transistor, and the "Pin-Outs" from the CPU/Sound Board. *Activating* the "DRAW" *Icon* when a switch is not closed, will give the generic switch schematic as shown below.

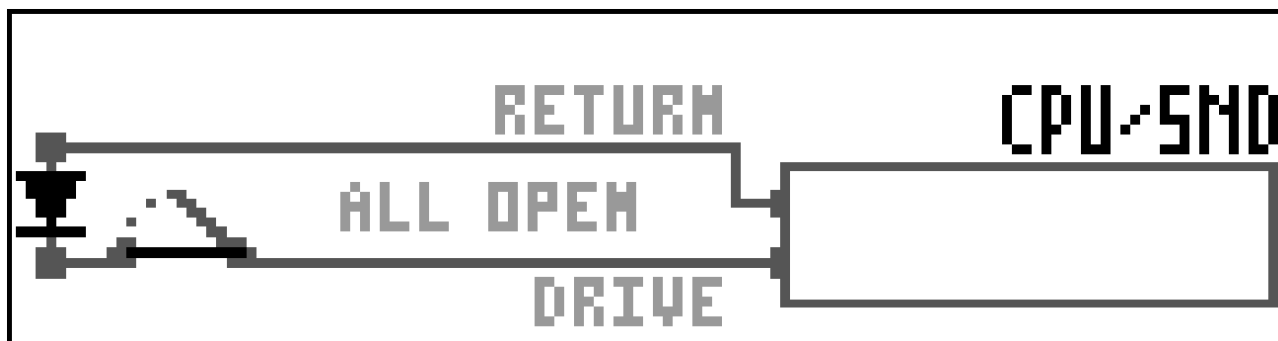

To **exit any display where there are no Mini-Icons** (Schematics or Help Displays), **press any button** to return to the previous Menu.

While in **Switch Test** or **Active Switch Test**, the **Flipper & Start Buttons** are deactivated (because they can be part of these tests). Use the **Red "LEFT," Green "RIGHT"** and/or **Black "ENTER" Buttons** to select and *activate* the "**MINI-ICONS**" at the bottom of the display. In **Switch Test**, if the "<<" or ">>" *Mini-Icon* is *activated*, the display will go to (slip between) the previous tests (*Active & Dedicated Switch Tests*). Use either the **Red** or **Green Button** to select the "PREV" *Mini-Icon*. Press the **Black "ENTER" Button** to return to **Switch Test Menu**. To exit out of this Sub-Menu, select and *activate* the "PREV" *Icon* in the Menu. The **DIAGNOSTICS MENU** now appears with the "SW" *Icon* (**GO TO SWITCH MENU**) flashing. Go through other **Diagnos**tics selections or exit.

To exit the **Portals™ Service Menu**, select & *activate* the "QUIT" *Icon* (see the next page).





QUIT THIS SESSION (Exiting the Portals™ Service Menu)

In the **MAIN MENU** and in all **SUB-MENUS**, if the "QUIT" *Icon* or "QUIT" *Mini-Icon* is selected and *activated*, the **Portals™ Service Menu Session** will be exited and returned to the **Attract Mode**.

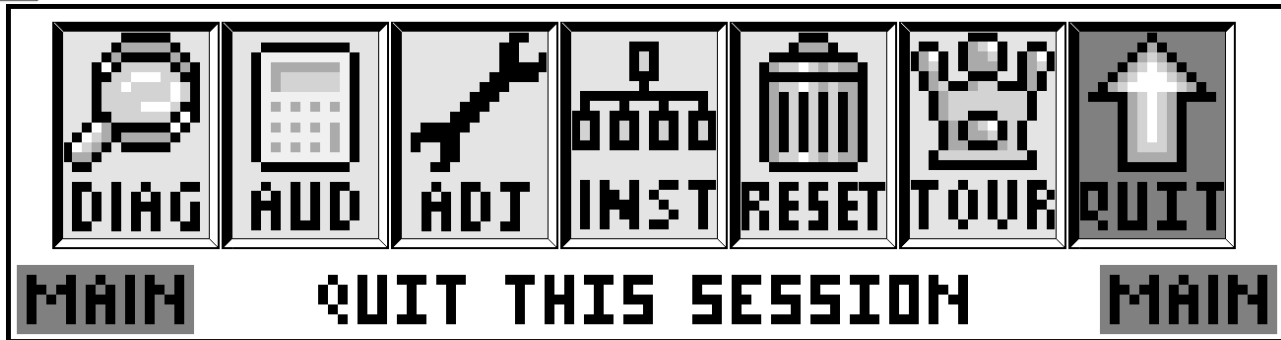

The game will go into the same *Power-Up Routine* as if turning on the game. Upon **Power-Up**, the CPU Game Code & Display Code versions with Check-Sums are shown, followed by the Location ID & Game ID Numbers and Alerts, if any (see *Section 3, Chapter 2, GO TO DIAGNOSTICS MENU, Technician Alerts*).

The below **Problem / Solution Table** was designed to answer some common problems frequently asked.

Problem / Solution Table

PROBLEM	SOLUTION
Will not enter the Service Mode after depressing the Black "BEGIN TEST" Button .	<ul style="list-style-type: none"> • Check the Service Switch(es) (Red, Green & Black Buttons) for loose connections or bad Ground. • Check the associated wiring harness to/from the CPU/Sound Board, Connector CN6. • Check CPU/Sound Board for possible failure.
All Service Buttons (Red, Green and Black) appear nonfunctional.	<ul style="list-style-type: none"> • Check the Service Switches wiring harness for poor or no connection and/or broken wires.
The Green Service Button in the Attract Mode will not enter the SERVICE CREDITS MENU to add Service Credits.	<ul style="list-style-type: none"> • Check to make sure the Game is not in "Free Play." <i>If the game is set to Free Play, adding Service Credits is not required.</i> • Check the Service Switches wiring harness for poor or no connection and/or broken wires.
The Display "blanks out."	<ul style="list-style-type: none"> • Check the Dot Matrix Display for loose wiring harness for poor or no connection and/or broken wires. • Check F1 (3/4A Fuse) on the Display Power Supply Board. Refer to Sec. 5, Chp. 4, SCHEMATICS & TROUBLESHOOTING.
Icons " <i>scroll</i> " along continuously in the MAIN MENU .	<ul style="list-style-type: none"> • Check for a stuck switch on the Green Button. • If the Service Switch Set and/or the Coin Door was replaced, ensure the Locking Mechanism on the Green Button was removed. If the Green Button "clicks" and locks into an up/down position, the Green Button has this lock switch. Remove it. (Ref. to Svc. Bulletin #74.)
The Start and Flipper Buttons do not select or activate <i>Icons</i> in the SWITCH TEST MENU .	<ul style="list-style-type: none"> • This is normal. These switches are deactivated, as they are a part of the Switch Test. Use the Red "LEFT" or Green "RIGHT" & Black "ENTER" Buttons in this Sub-Menu. Refer to Section 3, Chapter 2, GO TO DIAGNOSTICS MENU, Switch Test.
Can't move selection of <i>Icon</i> with the Left and/or Right Flipper Buttons .	<ul style="list-style-type: none"> • Check the Flipper Buttons for loose connections or bad Ground and refer to Section 5, Chapter 2, Playfield Wiring, #-Flipper Circuit Wiring Diagram. • This is normal <i>only</i> in Diagnostic's Switch & Active Switch Tests (see <i>previous Problem</i>).
Some <i>Icons</i> appear non-functional in the PRINTER MENU(S) .	<ul style="list-style-type: none"> • If no printing equipment is connected, the "-" Icon, "+" Icon and "RUN" Icon will appear not to function. Refer Section 3, Chapter 3, GO TO PRINTER MENU.
Some <i>Icons</i> appear non-functional in the GAME SPECIFIC MENU under the DIAGNOSTICS MENU .	<ul style="list-style-type: none"> • If there is no other test under this Menu, the "<<" & ">>" Mini-Icons will appear not to function. The remaining <i>Icons</i> should function as normal. Note: <i>If there is no "Go To (Game Name) Test(s), the "GAME NAME" Icon will not invoke another display.</i>
The display returns to the ATTRACT MODE exiting the Service Session after a FACTORY RESET .	<ul style="list-style-type: none"> • This is normal. After a FACTORY RESET, the Service Session is automatically exited. Refer to Sec. 3, Chp. 6, GO TO RESET MENU, Factory Reset.
In COIL TEST MENU , the coils and flashlamps <i>do not</i> fire after activating the "RUN" Icon .	<ul style="list-style-type: none"> • Ensure the POWER INTERLOCK SWITCH is pulled out (see the start of this Chapter).
In ADJUSTMENTS MENU , with the Coin Door CLOSED , adjustments are not getting changed as desired (using the Flipper & Start Buttons).	<ul style="list-style-type: none"> • This is normal. The Memory Protect Switch is enabled when the Coin Door is CLOSED. Changes can be made with the Coin Door OPEN only.
In Portals™ Service Menu , the volume cannot be adjusted with the Red or Green Buttons .	<ul style="list-style-type: none"> • The Volume adjustment can only be made when in the Attract Mode. The Volume Mode is entered by pressing the Red "VOLUME" Button. Then use the Red "LEFT" Button to decrease / decrement (-) or Green "RIGHT" Button to increase / increment (+) the volume.
In Portals™ Service Menu , the display seems to lock up, or the Help Display appears to be non-functional.	<ul style="list-style-type: none"> • If you cannot clear the situation by exiting back one Menu, exit completely out of the Portals™ Service Menu, and re-enter. If the problem persists, call Technical Support for additional help.

Sec. 3: ...Menu Intro.



Go To Diagnostics Menu

Overview

The **Portals™ Service Menu System** provides tests for sounds, display, lamps, switches and coils. Each feature may be tested manually or automatically after entering the **Portals™ Service Menu** (see Chapter 1 of this Section). The automatic tests (e.g. **Cycling Coils**, **Test Flash Lamps**) may be used for a quick verification of automatic test functions and the manual tests (**Begin Play Test**, **Single Lamp / All / Row / Column Tests**, and **'Game Name' Tests**) may be used for troubleshooting. All *Icons* and their usages are explained throughout this chapter in order.

Important: Upon **Power-up**, opening the **Coin Door** or exiting **Portals™**, watch the **Display** for any **Alerts**.



If this **display flashes**, the game is indicating that **CMOS RAM** memory (CPU Loc. U212) has been corrupted. This is caused by either failure in memory (e.g. **batteries are dead and/or faulty RAM**) or upon installation of updated version of game code. Opening the **Coin Door** will initiate a **Factory Restore (Reset)**, by opening the **Memory Protect Switch**.

Check battery voltage at **VBATT Test Point** on the **CPU/Sound Bd.** (more details in **Sec. 5, Chp. 4, PCBs**).



This **flashing display** is shown immediately upon opening the **Coin Door** as a reminder that **20v/50v DC** power to the playfield is **disabled**. All electro-mechanical devices (such as **Coils**) **cannot be tested** with the switch pushed in. **PULL OUT** the **Power Interlock Switch ONLY** if you're in a **Testing Menu** requiring power. See **Access & Use** in Chapter 1 of this Section for the location of this switch. **Closing the Coin Door** will automatically reset this switch.



This **display** is shown momentarily during **Game Mode** or **Power-Up** to alert the operator of a coil malfunction (*coil doesn't energize or coil fires a multiple number of times*). **OPERATOR ALERT!** works by monitoring any **switch activated coil** that has the potential to trap a ball when disabled (more details in this Chapter, **Technician Alerts, Pages 24-25**).



If this **display flashes** (along with an audible sound), the game has detected faulty switches and/or missing pinballs. To check, enter the **Portals™ Service Menu System**, select the **"DIAG" Icon** (**GO TO DIAGNOSTICS MENU**) from the **MAIN MENU** and select the **"TECH" Icon** (more details in this Chapter, **Technician Alerts, Pages 24-25**).

CAUTION: Remove pinballs from the Ball Trough prior to lifting the playfield for servicing. This can easily be done in the **Portals™ Service Menu System**. Select the **"DIAG" Icon** from the **MAIN MENU** to go to the **DIAGNOSTICS MENU**, then select the **"CLR" Icon** to enter the **CLEAR BALL TROUGH MENU**. Select the **"RUN" Mini-Icon** & press the **Start Button** to remove one ball at a time. This is also useful to retrieve one ball for game testing in **Begin Play Test** & **'Game Name' Tests**. **PULL OUT** the **Power Interlock Switch** for operation.

Sec. 3: ... Diagnostics



EXPLANATION & USAGE OF COMMON LARGE & MINI-ICONS USED IN VARIOUS MENUS & SUB-MENUS:

Select and activate to:

MORE MORE	PREV	QUIT	HELP	DECREMENT (-) or INCREMENT (+) displayed value or select previous / next.	RUN (or activate) selected test or coil PULSE coil.	View the schematic (DRAWING) of current display. Select while current switch, lamp or coil is viewed.
<small>These non-selectable icons appear in the selected Menu only when there are MORE icons to the LEFT or to the RIGHT available for selection.</small>	<small>Select and activate to return to the PREVIOUS Menu.</small>	<small>Select and activate to QUIT, exits & returns to the Attract Mode.</small>	<small>Select and activate to view HELP Screens of the current Menu*.</small>	<small>* Help Note: An explanation of each Mini-Icon at that menu level will cycle continuously. To exit a display where no Mini-Icons are available for selection, pressing any button will exit the display.</small>		

GO TO DIAGNOSTICS MENU

After entering **Portals™**, the **MAIN MENU** now appears. To initiate, from the **MAIN MENU**, select the **"DIAG" Icon** with either the **Red "LEFT"** or **Green "RIGHT" Buttons** (the **Flipper Buttons** operates in the same manner) and press the **Black "ENTER" Button** (the **Start Button** operates in the same manner). The **DIAGNOSTICS MENU** appears. Continue through this chapter for the explanation & usage of the **Icons** in the **DIAGNOSTICS MENU**. **Usage Note:** Only in **Switch & Active Switch Tests**, the **Flipper & Start Buttons cannot be used** as the alternate navigation buttons as they are a part of these tests. After exiting these tests, the **Left & Right Flipper** and **Start Buttons** can once again be used. Continue through this chapter for the explanation & usage of the **Icons** in the **DIAGNOSTICS MENU**.





Go To Switch Menu

To initiate, from the **DIAGNOSTICS MENU**, select the "SW" *Icon* with either the **Red "LEFT"** or **Green "RIGHT"** Buttons and press the **Black "ENTER"** Button. Switches are configured in an 8 x 8 Matrix of Columns (Switch Drives) and Rows (Switch Returns) with up to **64** possible switches. The **SWITCH TEST MENU** consists of three (3) parts: **Switch Test, Active Switches & Dedicated Switch Test**. **Reminder:** *The Flipper & Start Buttons (part of Switch Tests) cannot be used as navigation buttons during these test(s)*



Switch Test

To initiate, from the **SWITCH MENU**, select the "TEST" *Icon* with either the **Red or Green Buttons & press the Black Button**. In **Switch Test**, close each switch and observe the display. The display will describe the switch in the Switch Matrix Grid (below), which includes the switch name, Return (Row) Wire, Drive (Column) Wire and the "Pin-Outs" from the **CPU/Sound Board**. When the switch is closed, the information is displayed momentarily. To view the schematic for the switch selected, press either the **Red or Green Button** to select the "DRAW" *Mini-Icon*. Press the **Black Button** to *activate* this *Mini-Icon*; do so while the switch is momentarily closed. To return to **Switch Test**, press the **Black Button** again.



Active Switch Test

To initiate, from the **SWITCH MENU**, select the "ACT" *Icon* with either the **Red or Green Buttons & press the Black Button**. If still in a previous test, select the "PREV" *Mini-Icon* to return to **SWITCH MENU** or select either of the "<<" or ">>" *Mini-Icons* to move through the tests. In **Active Switch Test**, if any switches are stuck closed (*or made from the presence of a pinball*), the display sequences through the Switch Names, Return (Row) Wire, Drive (Column) Wire, Drive Transistor, Part Number and the "Pin-Outs" from the **CPU/Sound Board**. This cycle continues until all switches are cleared or until the test is exited.



Dedicated Switch Test

To initiate, from the **SWITCH MENU**, select the "DED" *Icon* with either **Flipper Button & press the Start Button** (*the Service Switches are deactivated during this test.*). In **Dedicated Switch Test**, the display will describe the switch which includes the Switch Name, Return (Row) Wire, Drive (Column) Wire, Part Number and the "Pin-Outs" from the **CPU/Sound Board**.

SWITCH MATRIX GRID & DEDICATED SWITCHES

Column (Drive)	1: Q1	2: Q2	3: Q3	4: Q4	5: Q5	6: Q6	7: Q7	8: Q8
Row (Return)	GRN-BRN CN5-P1	GRN-RED CN5-P3	GRN-ORG CN5-P4	GRN-YEL CN5-P5	GRN-BLK CN5-P6	GRN-BLU CN5-P7	GRN-VIO CN5-P8	GRN-GRY CN5-P9
1: U400	1 Cabinet Side LEFT BUTTON (UK ONLY) Sw. Part Number: 180-5160-00	9 Below P/F COMIC BOOK GUY STANDUP 515-6027-08	17 Below P/F DROP TARGET #1 (TOP) 180-5158-00	25 Abv. Upr. P/F UPPER PLAYFIELD EXIT 180-5190-28	33 Blw. Upr. P/F UPF LIGHT STANDUP 515-5966-04	41 Below P/F BULLY 3-BANK (TOP) 515-6027-08	49 Below P/F LEFT BUMPER 180-5015-03	57 Below P/F LEFT OUTLANE 500-6227-02
2: U400	2 Coin Door 4TH COIN SLOT 180-5204-00	10 Below P/F 5-BALL TROUGH #1 (LEFT) 180-5119-02	18 Below P/F DROP TARGET #2 (MID) 180-5158-00	26 Blw. Upr. P/F GARAGE RAMP ENTER 180-5190-28	34 Blw. Upr. P/F UPF LOCK STANDUP 515-5966-04	42 Below P/F BULLY 3-BANK (MID) 515-6027-08	50 Below P/F RIGHT BUMPER 180-5015-03	58 Below P/F LEFT RETURN LANE 500-6227-02
3: U400	3 Coin Door 6TH COIN SLOT Future Use	11 Below P/F 5-BALL TROUGH #2 180-5119-02	19 Below P/F DROP TARGET #3 (BOT) 180-5158-00	27 NOT USED	35 Blw. Upr. P/F UPF TOP STANDUP 515-5966-02	43 Below P/F BULLY 3-BANK (BOT) 515-6027-08	51 Below P/F BOTTOM BUMPER 180-5015-03	59 Below P/F LEFT SLINGSHOT 180-5054-00 (x2)
4: U400	4 Coin Door RIGHT COIN SLOT 180-5204-00	12 Below P/F 5-BALL TROUGH #3 180-5119-02	20 Below P/F ITCHY & SCRATCHY SAUCER 180-5116-01	28 NOT USED	36 Abv. Upr. P/F COUCH ENTER 180-5190-28	44 Above P/F UP RIGHT SAUCER BACKUP 180-5119-02	52 Below P/F POP SIDE STANDUP 515-6027-08	60 Below P/F RIGHT OUTLANE 500-6227-02
5: U401	5 Coin Door CENTER COIN SLOT / DBA 180-5204-00	13 Below P/F 5-BALL TROUGH #4 180-5119-02	21 Above P/F SPINNER 180-5010-04	29 Below P/F KWIK-E-MART LOOP 500-6227-02	37 Blw. Upr. P/F TV LOCKUP 500-6227-02	45 Above P/F RIGHT RAMP ENTER 180-5190-28	53 In Cabinet TOURNAMENT BUTTON 180-5174-00	61 Below P/F RIGHT RETURN LANE 500-6227-02
6: U401	6 Coin Door LEFT COIN SLOT 180-5204-00	14 Below P/F 5-BALL TROUGH VUK OPTO See Sw. 14 Note	22 Below P/F BART SKATEBOARD TOP 180-5190-48	30 Below P/F KWIK-E-MART STANDUP 515-5966-07	38 Abv. Upr. P/F COUCH LOCK (BOT) 180-5119-02	46 Above P/F RIGHT RAMP MADE 180-5190-28	54 In Cabinet START BUTTON 180-5174-00	62 Below P/F RIGHT SLINGSHOT 180-5054-00 (x2)
7: U401	7 Coin Door 5TH COIN SLOT Future Use	15 Below P/F 5-BALL STACKING OPTO See Sw. 15 Note	23 Below P/F BART SKATEBOARD 180-5190-48	31 Below P/F ADV. POPS STANDUP 515-5966-07	39 Abv. Upr. P/F COUCH LOCK (MID) 180-5119-02	47 Above P/F LEFT RAMP ENTER 180-5116-01	55 Below P/F UPPER LEFT VUK 180-5116-01	63 Below P/F LEFT ORBIT 500-6227-02
8: U401	8 Cabinet Side RIGHT BUTTON (UK ONLY) 180-5160-00	16 Below P/F SHOOTER LANE 180-5157-00	24 Below P/F UPPER RIGHT SAUCER 180-5186-00	32 Below P/F LIGHT OTTO STANDUP 515-5966-08	40 Abv. Upr. P/F COUCH LOCK (TOP) 180-5119-02	48 Below P/F GARAGE DOOR 500-6138-01R	56 In Cabinet PLUMB BOB TILT See Sw. 56 Note	64 Below P/F RIGHT ORBIT 500-6227-02

GROUND	GROUND
1: U206 GRY-BRN CN6-P2 Sw. Part Number: 180-5160-00	DS-1 on Cabinet Side #1 LEFT FLIPPER BUTTON 180-5160-00
2: U206 GRY-RED CN6-P3 Sw. Part Number: 180-5149-00 on Flipper	DS-2 Below Playfield #2 LEFT FLIPPER E.O.S (End-of-Stroke) 180-5149-00 on Flipper
3: U206 GRY-ORG CN6-P4 Sw. Part Number: 180-5164-00 Doubled	DS-3 on Cabinet Side #3 RIGHT FLIPPER BUTTON 180-5164-00 Doubled
4: U206 GRY-YEL CN6-P6 Sw. Part Number: 180-5149-00 on Flipper	DS-4 Below Playfield #4 RIGHT FLIPPER E.O.S (End-of-Stroke) 180-5149-00 on Flipper
5: U206 GRY-GRN CN6-P7 Sw. Part Number: 180-5164-00 Doubled	DS-5 on Cabinet Side #5 UPPER RT. FLIPPER BUTTON 180-5164-00 Doubled
6: U206 GRY-BLU CN6-P8 Sw. Part Number: 180-5192-02	DS-6 on Coin Door #6 VOLUME (RED BUTTON) (In Test: LEFT) 180-5192-02
7: U206 GRY-VIO CN6-P9 Sw. Part Number: 180-5192-04	DS-7 on Coin Door #7 SERV. CRED. (GREEN BUTTON) (In Test: RIGHT) 180-5192-04
8: U206 GRY-BLK CN6-P10 Sw. Part Number: 180-5192-00	DS-8 on Coin Door #8 BEGIN TEST (BLACK BUTTON) (In Test: ENTER) 180-5192-00

Sec. 3: ... Diagnostics



SWITCH MATRIX GRID LOCATIONS

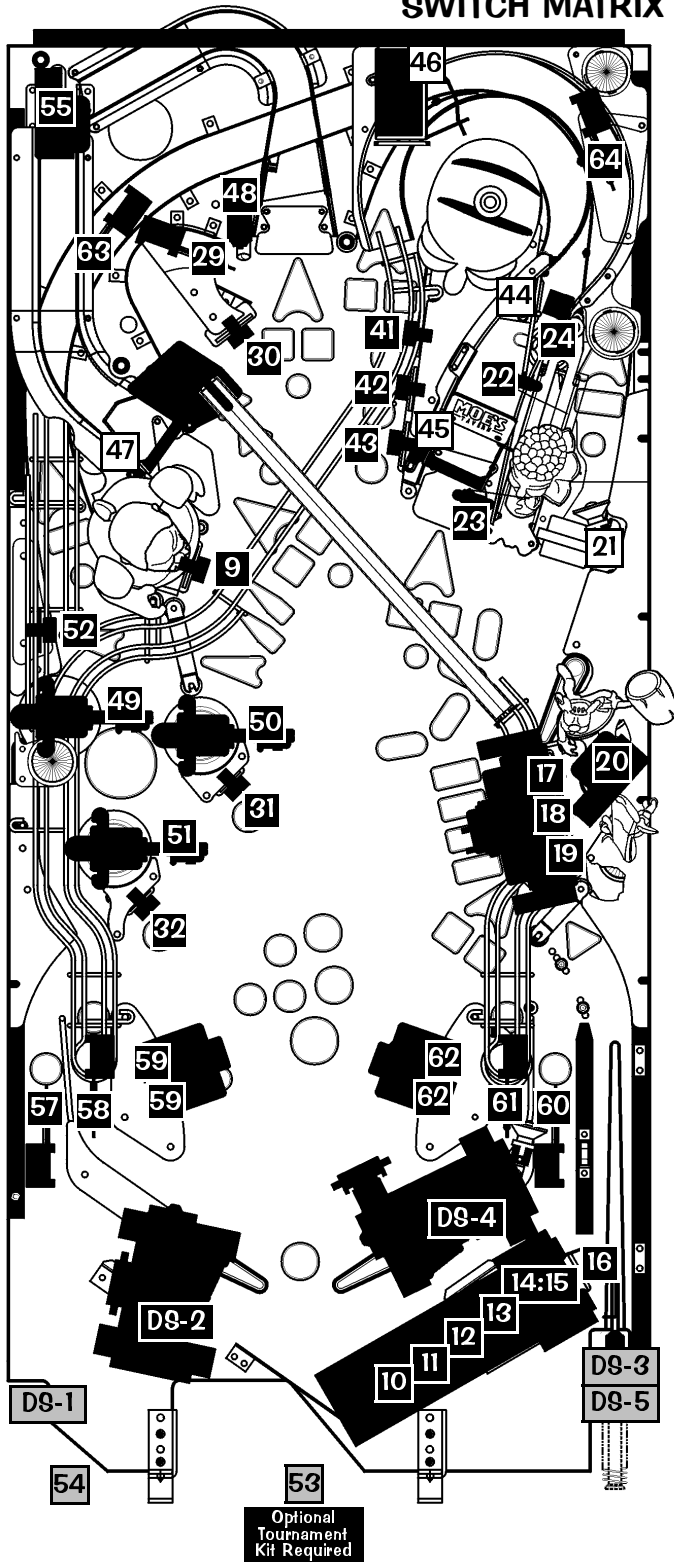

Upper Playfield - Upper Right Corner

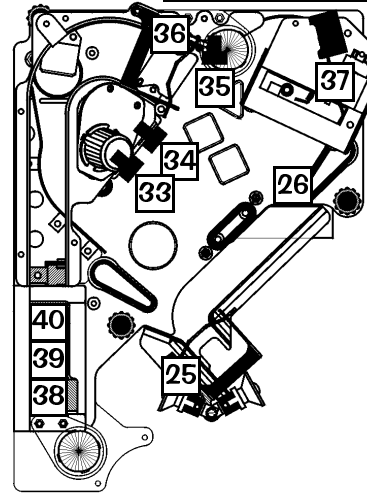

Typical Switch Wiring & Schematic

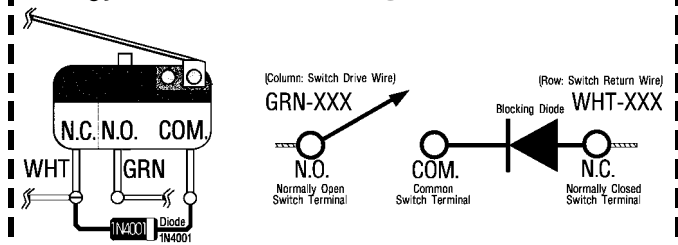

Dedicated Switch Schematic

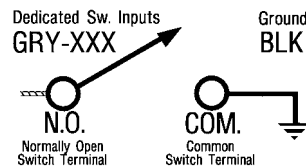

Sec. 3: ... Diagnostics

LEGEND NOTE:

□ = Switches mounted above the Playfield. ■ = Switches mounted below the Playfield. ▒ = Switches mounted in the Cabinet.

Switch Part Note: ¥ Yen Coin Switch is 180-5091-00. Part numbers which start with 515- or 500- include the bracket, target, and/or housing. Targets: See Appendix I, Stand-Up Targets, for pictorial views. Switches are listed again in the Pink and Blue Pages and list the assembly and securing hardware they're used on.

Sw. 14 & 15 Part Note: Transmitter & Receiver OPTO PC Boards are used for both Switches 14 & 15. Transmitter: 515-0173-00; Receiver: 515-0174-00.

Switch 56 Part Note: The Switch is comprised of a Hanger Bracket (535-5319-00) and Contact Wire (535-7563-01) located in the Cabinet.

Some Switch Diodes are located under the playfield on Terminal Strips or Diode Boards and not on the assemblies.

DOTS: Diode On Terminal Strip or DODB: Diode On Diode Board (only if noted in the Matrix Grid).

Go To
Diagnostics Menu



Section 3, Chapter 2
Page 17



Go To Coil Menu

To initiate, from the **DIAGNOSTICS MENU**, select the "COIL" *Icon* with either the **Red "LEFT"** or **Green "RIGHT" Buttons** and press the **Black "ENTER" Button**. The coils are listed in groups. Coils **01-16** are typically High Current Coils (*although Low Current Coils may be used in these positions & will be noted*). Coils **17-32** are typically Low Current Coils. Flash Lamps are typically used in positions **26-32** (*although may be used in any position & will be noted*).



PULL OUT the Power Interlock Switch for operation with the Coin Door open.

Important: The Partial Coils Detailed Chart Table is used as a reference against the Coil & Flash Lamp Locations on the next page. For the **complete** Coils Detailed Chart Table, see the reverse of the following page. The Chart is shown to compare against the Backbox I/O Power Driver Board Detailed Wiring Diagram (shown again in Sec. 5, Chapter 1, **Playfield Wiring**). For more on troubleshooting and diagnosing, see Sec. 5, Chapter 4, **Printed Circuit Boards**.



Single Coil Test

To initiate, from the **COIL MENU**, select the "TEST" *Icon* with either the **Red or Green Buttons** and press the **Black Button**. Ensure the **Power Interlock Switch** is pulled out. Select either the "-" or "+" *Mini-Icons*. Start with the "+" *Mini-Icon* to start the manual **Single Coil Test** from #1 (*the test runs through all Coils and Flash Lamps #1-#32 & Optional UK Only Auxiliary Positions AUX 1-3*). Press the **Black Button** on the "+" *Mini-Icon*, as each coil is selected, the display will describe the Coil or Flash Lamp Name with the corresponding number, the wire with colors, the "Pin-Outs" from the I/O Power Driver Board, the Coil Voltage and Gauge-Turns (*e.g. 23-800*). Press the **Black Button** again to move forward in the test. To test and view a particular Coil or Flash Lamp, select the "RUN" *Mini-Icon* and press the **Black Button**. Each time the **Black Button** is pushed, the Coil or Flash Lamp will fire on the Playfield and/or Backbox, with the display indicating the Coil or Flash Lamp information. Continue with the same procedure to run through the entire test.



Cycling Coil Test

To initiate, from the **COIL MENU**, select the "CYC" *Icon* with either the **Red or Green Buttons** and press the **Black Button**. If still in a previous test, select the "PREV" *Mini-Icon* to return to **COIL MENU** or select either of the "<<" or ">>" *Mini-Icons* to move to **Cycling Coil Test** (*selecting again will return to Coil Test*). The test pulses each regular Coil or Flash Lamp sequentially (*cycling*) on the Playfield and in the Backbox (*if Coils are used*). The display indicates **CYCLING COILS**.

PARTIAL COILS DETAILED CHART...

High Current Coils Group 1		Drive Transistor	Coil GA-Turn or Bulb Type
#1	TROUGH UP-KICKER	Q1	26-1200 090-5044-00T
#2	AUTO LAUNCH	Q2	26-1200 090-5044-00T
#3	COUCH RELEASE	Q3	28-1050 090-5046-00
#4	DROPS RESET UP	Q4	26-1200 090-5044-00T
#5	ITCHY & SCRATCHY EJECT (VUK)	Q5	27-1500 090-5004-00T
#6	UPPER LEFT VUK	Q6	26-1200 090-5044-00B
#7	TV RELEASE	Q7	28-1050 090-5046-00
#8	HOMER HEAD	Q8	22-900 090-5020-20T
High Current Coils Group 2		Drive Transistor	Coil GA-Turn or Bulb Type
#9	LEFT BUMPER	Q9	26-1200 090-5044-00T
#10	RIGHT BUMPER	Q10	26-1200 090-5044-00T
#11	BOTTOM BUMPER	Q11	26-1200 090-5044-00T
#12	UPF LEFT FLIPPER	Q12	25-1800 090-5041-00T
#13	UPF RIGHT FLIPPER	Q13	24-1570 090-5025-00T
#14	TOP RIGHT FLIPPER	Q14	23-1100 090-5030-00T
#15	LEFT FLIPPER (50v RED/YEL)	Q15	22-1080 090-5032-00T
#16	RIGHT FLIPPER (50v RED/YEL)	Q16	22-1080 090-5032-00T
Low Current Coils Group 1		Drive Transistor	Coil GA-Turn or Bulb Type
#17	LEFT SLINGSHOT	Q17	23-800 090-5001-00T
#18	RIGHT SLINGSHOT	Q18	23-800 090-5001-00T
#19	UPPER RIGHT EJECT	Q19	26-1200 090-5044-00T
#20	GARAGE DOOR (EJECT)	Q20	26-1200 090-5044-00T
#21	FLASH: POPS CLEAR	Q21	#906 Bulb 165-5004-00
#22	FLASH: R.RAMP RED	Q22	#906 Bulb 165-5004-00
#23	FLASH: R.RAMP ORANGE	Q23	#906 Bulb 165-5004-00
#24	OPTIONAL COIL	Q24	Opt. 5v
Diode On Terminal Strip (if noted)			
Low Current Coils Group 2		Drive Transistor	Coil GA-Turn or Bulb Type
#25	FLASH: ITCHY	Q25	#906 Bulb 165-5004-00
#26	FLASH: SCRATCHY	Q26	#906 Bulb 165-5004-00
#27	FLASH: HOMER HEAD	Q27	#906 Bulb 165-5004-00
#28	FLASH: COUCH	Q28	#906 Bulb 165-5004-00
#29	FLASH: COMIC BOOK GUY	Q29	#906 Bulb 165-5004-00
#30	DROP BANK TRIPS	Q30	32-1250 515-6916-01
#31	FLASH: UPF ORANGE	Q31	#906 Bulb 165-5004-00
#32	FLASH: UPF RED	Q32	#906 Bulb 165-5004-00
Auxiliary (UK ONLY)		Drive Transistor	Coil GA-Turn
AUX 1: LEFT UP/DOWN POST		Q1	26-1200 090-5044-00T
AUX 2: CENTER UP/DOWN POST		Q2	23-1100 090-5030-00T
AUX 3: RIGHT UP/DOWN POST		Q3	26-1200 090-5044-00T



COIL & FLASH LAMP LOCATIONS

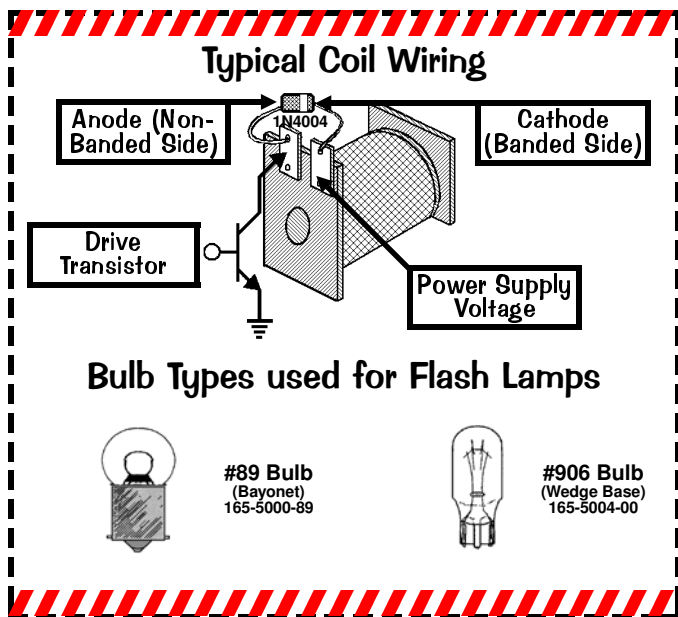
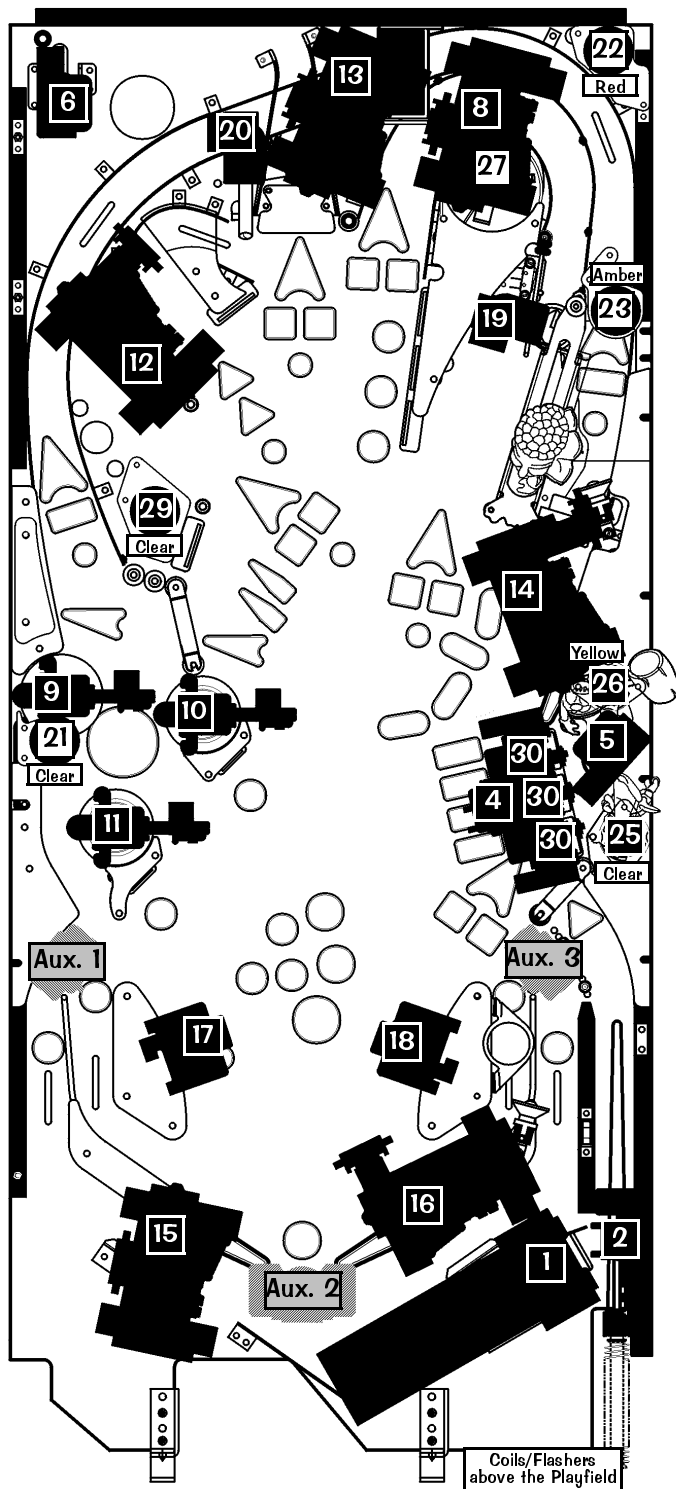

Sec. 3: ... Diagnostics

LEGEND NOTE:

□ = Coils / Flash Lamps mounted above the Playfield. ■ = Coils / Flash Lamps mounted below the Playfield. ▒ = Coils / Flash Lamps mounted in the Cabinet.

Coil Q24 is Optional. If a Coin Meter, Token Dispenser or Knocker is required (both optional) call Technical Support for more information, 1-800-542-5377 or 1-708-345-7700. Auxiliary Coils AUX 1 - AUX 3 are typically for UK Only.

Flash Lamp Part Note: [Color] = Color of Mini-Mars over bulb.

Some Coil / Flash Lamp Diodes are located under the playfield on Terminal Strips or Diode Boards and not on the assemblies.

DOTS: Diode Qn Terminal Strip or DODB: Diode Qn Diode Board (only if noted in the Chart Table).

Go To
Diagnostics Menu





In COIL MENU also select:

CYCLING COIL TEST

COILS DETAILED CHART TABLE

High Current Coils Group 1		Drive Transistor	Driver Output Board	Power Line Color	Power Line Connection	Power Voltage	Drive Transistor Control Line Color	D.T. Control Line Connect	Coil GA-Turn or Bulb Type
#1	TROUGH UP-KICKER	Q1	▲ I/O Power Driver ▼	YEL-VIO	J10-P4/5	50v DC	BRN-BLK	J8-P1	26-1200 090-5044-00T
#2	AUTO LAUNCH	Q2		YEL-VIO	J10-P4/5	50v DC	BRN-RED	J8-P3	26-1200 090-5044-00T
#3	COUCH RELEASE	Q3		YEL-VIO	J10-P4/5	50v DC	BRN-ORG	J8-P4	28-1050 090-5046-00
#4	DROPS RESET UP	Q4		YEL-VIO	J10-P4/5	50v DC	BRN-YEL	J8-P5	26-1200 090-5044-00T
#5	ITCHY & SCRATCHY EJECT (VUK)	Q5		YEL-VIO	J10-P4/5	50v DC	BRN-GRN	J8-P6	27-1500 090-5004-00T
#6	UPPER LEFT VUK	Q6		YEL-VIO	J10-P4/5	50v DC	BRN-BLU	J8-P7	26-1200 090-5044-00B
#7	TV RELEASE	Q7		YEL-VIO	J10-P4/5	50v DC	BRN-VIO	J8-P8	28-1050 090-5046-00
#8	HOMER HEAD	Q8		GRY-3A Fuse-BRN	J7-P1	20v DC	BRN-GRY	J8-P9	22-900 090-5020-20T
High Current Coils Group 2		Drive Transistor	Driver Output Board	Power Line Color	Power Line Connection	Power Voltage	Drive Transistor Control Line Color	D.T. Control Line Connect	Coil GA-Turn or Bulb Type
#9	LEFT BUMPER	Q9	▲ I/O Power Driver ▼	YEL-VIO	J10-P4/5	50v DC	BLU-BRN	J9-P1	26-1200 090-5044-00T
#10	RIGHT BUMPER	Q10		YEL-VIO	J10-P4/5	50v DC	BLU-RED	J9-P2	26-1200 090-5044-00T
#11	BOTTOM BUMPER	Q11		YEL-VIO	J10-P4/5	50v DC	BLU-ORG	J9-P4	26-1200 090-5044-00T
#12	UPF LEFT FLIPPER	Q12		GRY-3A Fuse-RED-YEL	J10-P1/2	50v DC	BLU-YEL	J9-P5	25-1800 090-5041-00T
#13	UPF RIGHT FLIPPER	Q13		BLU-YEL-3A Fuse-RED-YEL	J10-P1/2	50v DC	BLU-GRN	J9-P6	24-1570 090-5025-00T
#14	TOP RIGHT FLIPPER	Q14		BLU-YEL-3A Fuse-RED-YEL	J10-P1/2	50v DC	BLU-BLK	J9-P7	23-1100 090-5030-00T
#15	LEFT FLIPPER (50v RED/YEL)	Q15		GRY-YEL-3A Fuse-RED-YEL	J10-P1/2	50v DC	ORG-GRY	J9-P8	22-1080 090-5032-00T
#16	RIGHT FLIPPER (50v RED/YEL)	Q16		BLU-YEL-3A Fuse-RED-YEL	J10-P1/2	50v DC	ORG-VIO	J9-P9	22-1080 090-5032-00T
Low Current Coils Group 1		Drive Transistor	Driver Output Board	Power Line Color	Power Line Connection	Power Voltage	Drive Transistor Control Line Color	D.T. Control Line Connect	Coil GA-Turn or Bulb Type
#17	LEFT SLINGSHOT	Q17	▲ I/O Power Driver ▼	BRN	J7-P1	20v DC	VIO-BRN	J7-P2	23-800 090-5001-00T
#18	RIGHT SLINGSHOT	Q18		BRN	J7-P1	20v DC	VIO-RED	J7-P3	23-800 090-5001-00T
#19	UPPER RIGHT EJECT	Q19		BRN	J7-P1	20v DC	VIO-ORG	J7-P4	26-1200 090-5044-00T
#20	GARAGE DOOR (EJECT)	Q20		BRN	J7-P1	20v DC	VIO-YEL	J7-P6	26-1200 090-5044-00T
#21	FLASH: POPS CLEAR	Q21		ORG	J6-P10	20v DC	VIO-GRN	J7-P7	#906 Bulb 165-5004-00
#22	FLASH: R.RAMP RED	Q22		ORG	J6-P10	20v DC	VIO-BLU	J7-P8	#906 Bulb 165-5004-00
#23	FLASH: R.RAMP ORANGE	Q23		ORG	J6-P10	20v DC	VIO-BLK	J7-P9	#906 Bulb 165-5004-00
#24	OPTIONAL COIL	Q24		RED	J16-P7	5v DC	VIO-GRY	J7-P10	Opt. 5v
Dioded On Terminal Strip (if noted)									
Low Current Coils Group 2		Drive Transistor	Driver Output Board	Power Line Color	Power Line Connection	Power Voltage	Drive Transistor Control Line Color	D.T. Control Line Connect	Coil GA-Turn or Bulb Type
#25	FLASH: ITCHY	Q25	▲ I/O Power Driver ▼	ORG	J6-P10	20v DC	BLK-BRN	J6-P1	#906 Bulb 165-5004-00
#26	FLASH: SCRATCHY	Q26		ORG	J6-P10	20v DC	BLK-RED	J6-P2	#906 Bulb 165-5004-00
#27	FLASH: HOMER HEAD	Q27		ORG	J6-P10	20v DC	BLK-ORG	J6-P3	#906 Bulb 165-5004-00
#28	FLASH: COUCH	Q28		ORG	J6-P10	20v DC	BLK-YEL	J6-P4	#906 Bulb 165-5004-00
#29	FLASH: COMIC BOOK GUY	Q29		ORG	J6-P10	20v DC	BLK-GRN	J6-P5	#906 Bulb 165-5004-00
#30	DROP BANK TRIPS	Q30		BRN	J7-P1	20v DC	BLK-BLU	J6-P6	32-1250 515-6916-01
#31	FLASH: UPF ORANGE	Q31		ORG	J6-P10	20v DC	BLK-VIO	J6-P7	#906 Bulb 165-5004-00
#32	FLASH: UPF RED	Q32		ORG	J6-P10	20v DC	BLK-GRY	J6-P8	#906 Bulb 165-5004-00
Note: In Test Flash Lamps Menu ("Flash" Icon), Flashers tested are all Flash Lamps located between Q1-Q32 (This Game: Q21-Q23, Q25-Q29, Q31-Q32)									
Auxiliary (UK ONLY)		Drive Transistor	Driver Output Board	Power Line Color	Power Line Connection	Power Voltage	Drive Transistor Control Line Color	D.T. Control Line Connect	Coil GA-Turn
AUX 1: LEFT UP/DOWN POST		Q1	Solenoid Expander Auxiliary	BRN	J7-P1	20v DC	WHT	CN2-P5	26-1200 090-5044-00T
AUX 2: CENTER UP/DOWN POST		Q2		BRN	J7-P1	20v DC	RED	CN2-P4	23-1100 090-5030-00T
AUX 3: RIGHT UP/DOWN POST		Q3		BRN	J7-P1	20v DC	ORG	CN2-P3	26-1200 090-5044-00T

Sec. 3: ... Diagnostics



Backbox I/O Power Driver Board Detailed Wiring Diagram

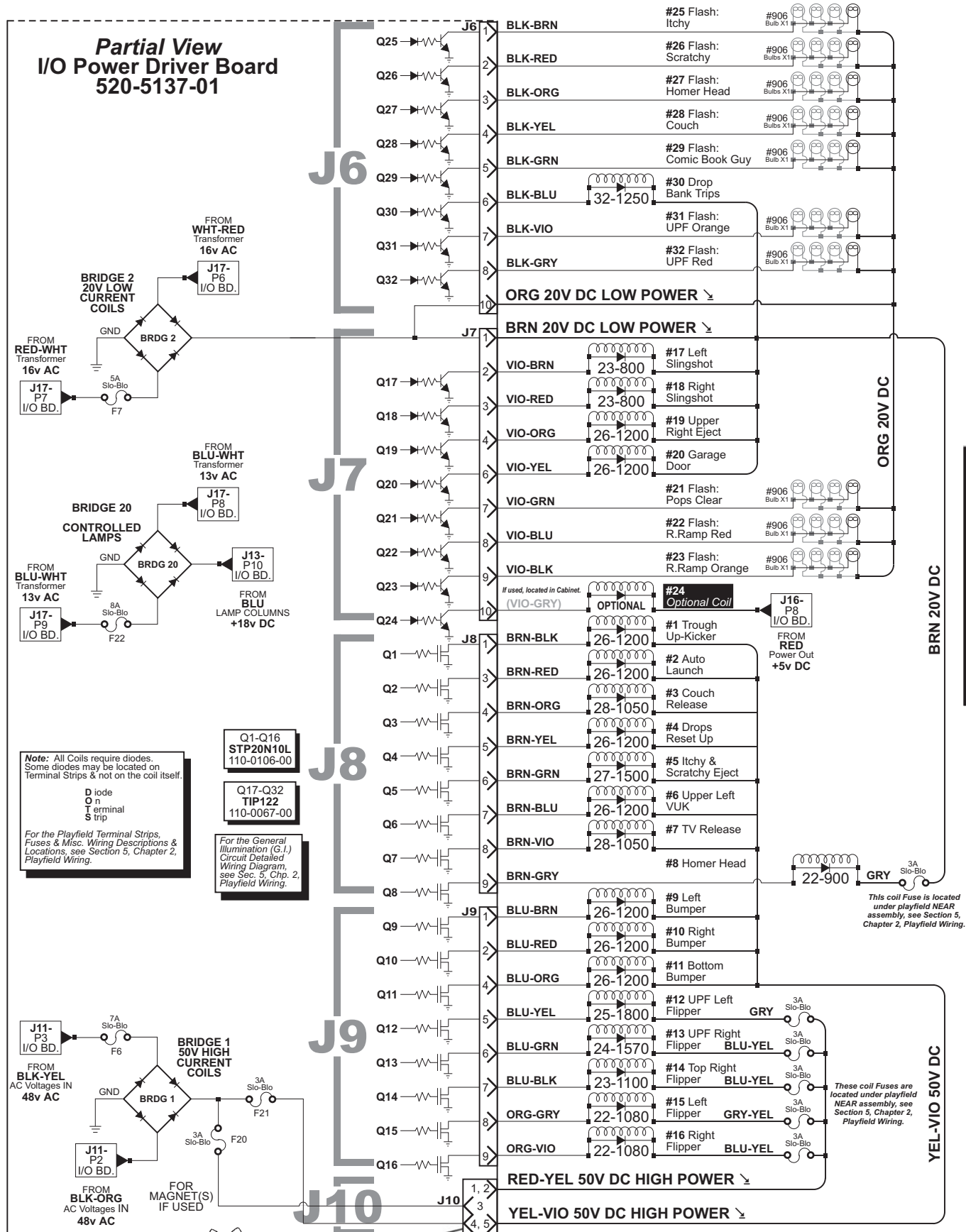

Sec. 3: ... Diagnostics

Go To
Diagnostics Menu

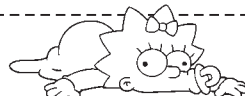

Section 3, Chapter 2
Page 21



Go To Lamp Menu

To initiate, from the **DIAGNOSTICS MENU**, select the "LAMP" *Icon* with either the **Red "LEFT"** or **Green "RIGHT"** **Buttons** and press the **Black "ENTER"** **Button**. Controlled lamps are configured in an 8 x 10 Matrix of Columns (Lamp Drives) and Rows (Lamp Returns) with up to **80** lamps possible. The Lamp Test Menu consists of four (4) parts: **Single Lamp Test**, **Test All Lamps**, **Row Lamp Test** & **Column Lamp Test**.



Single Lamp Test

To initiate, from the **LAMP MENU**, select the "ONE" *Icon* with either the **Red or Green Buttons** and press the **Black Button**. Select either the "-" or "+" *Mini-Icons*. Start with the "+" *Mini-Icon* to start the manual **Single Lamp Test** from Column 1, Row 1, Switch 1. Press the **Black Button** on the "+" *Mini-Icon*, as each lamp is selected, the lamp will light at its location on the playfield as well as the display, indicating the Lamp Matrix Grid Position (*below*), lamp name with the corresponding number, Return (Row) Wire & Color, Drive (Column) Wire & Color, and associated drive transistors. Press the **Black Button** again to move forward in the test. To test and view a particular lamp, select the "RUN" *Mini-Icon* and press the **Black Button**. Each time the **Black Button** is pushed, the lamp will light-up on the playfield, with the display indicating the lamp information. *Continue with the same procedure to run through the entire test.*



Test All Lamps

To initiate, from the **LAMP MENU**, select the "ALL" *Icon* with either the **Red or Green Buttons** and press the **Black Button**. If still in **Single Lamp Test** (or any 1 of the 4 tests), select the "PREV" *Mini-Icon* to return to **LAMP MENU** or select either of the "<<" or ">>" *Mini-Icons* to move through the tests, keep activating until **Test All Lamps** is displayed. The display will indicate **ALL LAMPS ON** and the lamps on the playfield will be lit, alternating between the rows in the Lamp Matrix Grid.



Row & Column Lamp Tests

To initiate, from the **LAMP MENU**, select the "ROW" or "COL" *Icon* with either the **Red or Green Buttons** and press the **Black Button**. If still in a previous test, select the "PREV" *Mini-Icon* to return to **LAMP MENU** or select either of the "<<" or ">>" *Mini-Icons* to move through the tests, keep activating until **Row** or **Column Lamp Test** (*whichever desired*) is displayed. In this test, each set of lamps in each Row or Column of the Lamp Matrix Grid (*respective to each test*) will light-up on the playfield and is indicated in the display.



Sec. 3: ... Diagnostics

LAMP MATRIX GRID

Column (18v)	1: U17	2: U16	3: U15	4: U14	5: U13	6: U12	7: U11	8: U10
Row (Ground)	YEL-BRN J13-P9	YEL-RED J13-P8	YEL-ORG J13-P7	YEL-BLK J13-P6	YEL-GRN J13-P5	YEL-BLU J13-P4	YEL-VIO J13-P3	YEL-GRY J13-P1
1: Q33	1 #555 Bulb RED-BRN J12-P1 LEFT OUT EXTRA BALL	2 #555 Bulb LEFT RETURN EXTRA BALL	3 #555 Bulb SHOOT AGAIN	4 #555 Bulb RIGHT RETURN EXTRA BALL	5 #555 Bulb SPECIAL	6 #555 Bulb SHOOTER LANE SKILL SHOT	7 #555 Bulb LIGHT OTTO	8 #555 Bulb ADV. POPS
2: Q34	9 #555 Bulb RED-BLK J12-P2 SPAY ANYTHING	10 #555 Bulb KITTY KITTY BANG BANG	11 #555 Bulb FIELD OF SCREAMS	12 #555 Bulb ESOPHAGUS NOW	13 #555 Bulb I&S ARROW	14 #555 Bulb START I&S MULTIBALL	15 #555 Bulb I&S 2X SCORING	16 #44 Bulb (x2) POPS 2X SCORING
3: Q35	17 #555 Bulb RED-ORG J12-P3 LEFT POP BUMPER	18 #555 Bulb RIGHT POP BUMPER	19 #555 Bulb BOTTOM POP BUMPER	20 #555 Bulb MORE TIME	21 #555 Bulb COLLECT NUCLEAR PLANT	22 #555 Bulb LEFT ORBIT ARROW	23 #555 Bulb CLETUS 2X SCORING	24 #555 Bulb LEFT ORBIT HURRY UP
4: Q36	25 #555 Bulb RED-YEL J12-P4 CBG SKILL SHOT	26 #555 Bulb CGB START HURRY UP	27 #555 Bulb DAREDEVIL RAMPERS	28 #555 Bulb DAREDEVIL BUMPERS	29 #555 Bulb DAREDEVIL LOOPS	30 #555 Bulb DAREDEVIL TARGETS	31 #555 Bulb START BUTTON	32 #555 Bulb TOURNAMENT BUTTON
5: Q37	33 #555 Bulb RED-GRN J12-P5 LEFT RAMP ARROW	34 #555 Bulb TREEHOUSE OF HORROR	35 #555 Bulb TREEHOUSE 2X SCORING	36 #555 Bulb LEFT RAMP HURRY UP	37 #555 Bulb RIGHT RAMP ARROW	38 #555 Bulb GET DUFFED!	39 #555 Bulb MOE'S 2X SCORING	40 #555 Bulb RIGHT RAMP HURRY UP
6: Q38	41 #555 Bulb RED-BLU J12-P6 MINI LOOP ARROW	42 #555 Bulb 2X SCORING KWIK-E-MART	43 #555 Bulb KWIK-E-MART HURRY UP	44 #555 Bulb GARAGE ARROW	45 #555 Bulb CLEAN THE GARAGE	46 #555 Bulb GARAGE 2X SCORING	47 #555 Bulb GARAGE HURRY UP	48 #555 Bulb RIGHT ORBIT ARROW
7: Q39	49 #555 Bulb RED-VIO J12-P8 RIGHT LOOP ARROW	50 #555 Bulb OTTO'S BUS TOURS	51 #555 Bulb ELEMENTARY 2X SCORING	52 #555 Bulb BULLY 3-BANK (TOP)	53 #555 Bulb BULLY 3-BANK (MID)	54 #555 Bulb BULLY 3-BANK (BOT)	55 #555 Bulb KRUSTY 2X SCORING	56 #555 Bulb RIGHT ORBIT HURRY UP
8: Q40	57 #555 Bulb RED-GRY J12-P9 HOMER	58 #555 Bulb MARGE	59 #555 Bulb BART	60 #555 Bulb LISA	61 #555 Bulb MAGGIE	62 #555 Bulb GRANDPA	63 #44 Bulb LEFT HEADLIGHT	64 #44 Bulb RIGHT HEADLIGHT
9: Q41	65 #555 Bulb RED-WHT J12-P10 LIVING ROOM 2X SCORING	66 #555 Bulb (LIGHT) LOCK	67 #555 Bulb LIGHT (LOCK)	68 #555 Bulb LOCK (SQUARE)	69 #555 Bulb SUPER JACKPOT	70 #555 Bulb TV ARROW	71 NOT USED	72 NOT USED
10: Q42	73 Green LED RED J12-P11 (LED) DUFFMAN	74 Green LED (LED) HOMER'S DAY	75 Green LED (LED) WILLIE'S WOES	76 Green LED (LED) WIGGUM VS SNAKE	77 Green LED (LED) BART'S DAY	78 Green LED (LED) KRUSTY'S LAST STAND	79 Green LED (LED) STOP THE MONORAIL	80 Red LED (x2) (LED) ALIEN INVASION



LAMP MATRIX GRID LOCATIONS

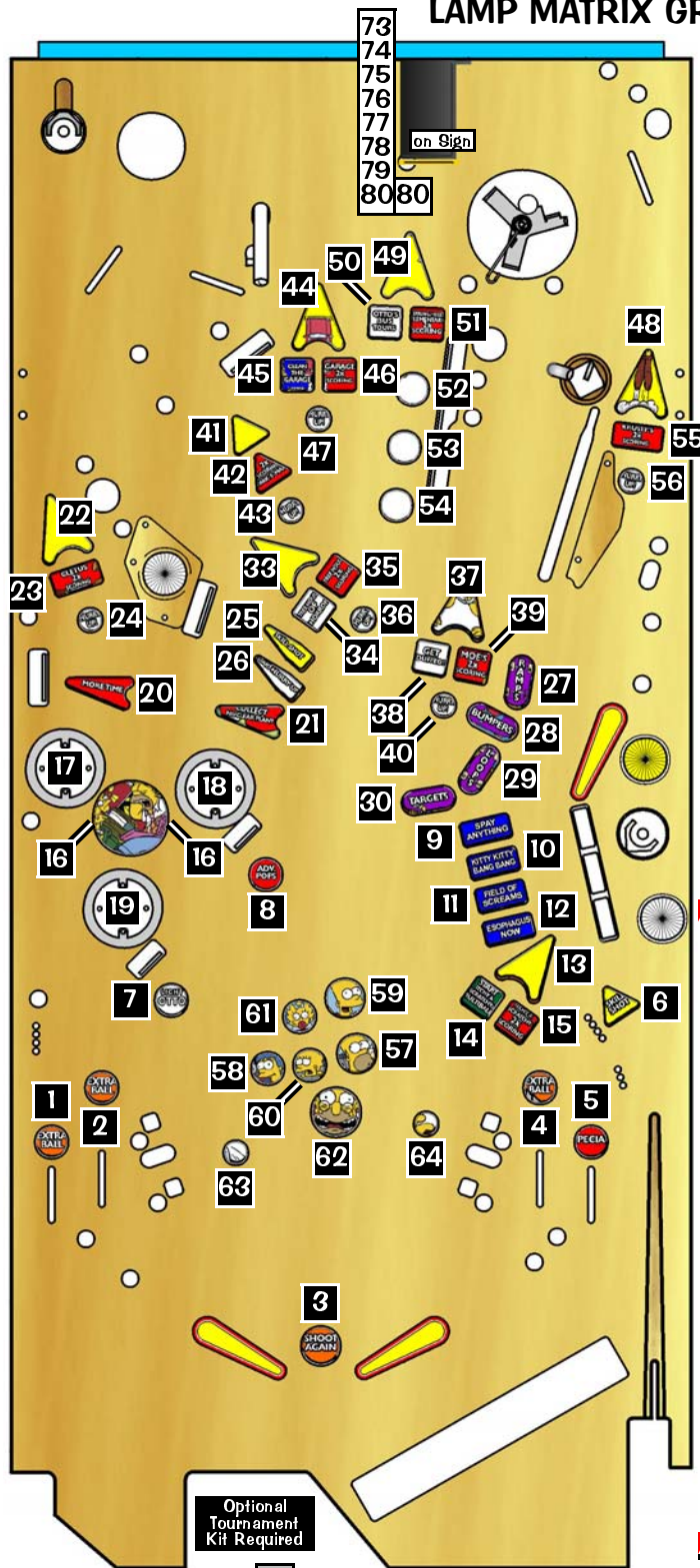

Upper Playfield - Upper Right Corner

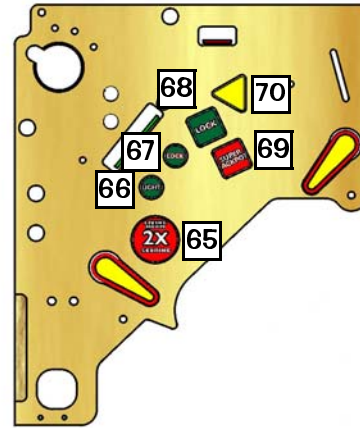

Typical Lamp Wiring & Schematic

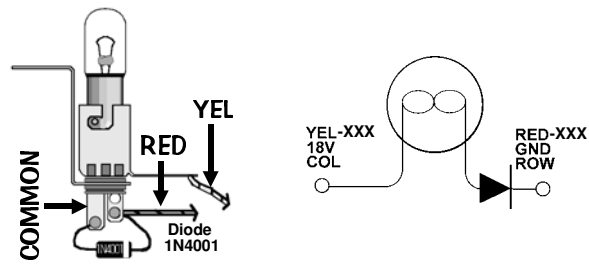

Bulb Types used for Lamps

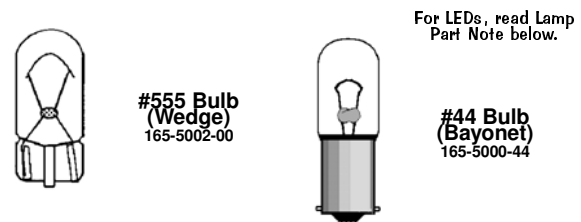

31

32

LEGEND NOTE:

□ = Lamps mounted above the Playfield. ■ = Lamps mounted below the Playfield. ▒ = Lamps mounted in the Cabinet.

Lamp Part Note: #555 Bulb Clear = 165-5002-00. #44 Bulb Clear = 165-5000-44. See Section 4, Chapter 1, **Parts Id. & Location**, Pages 72-74 for more details on bulbs and corresponding sockets.

Lamp Part Note: For Green or Red LEDs are attached to LED PC Bd., 520-5219-00. See Section 5, Chapter 4, **Printed Circuit Boards (PCBs)**, Page 143.

Some Lamp Diodes are located under the playfield on Terminal Strips or Diode Boards and not on the assemblies.

DOTS: Diode On Terminal Strip or DODB: Diode On Diode Board (only if noted in the Matrix Grid).

Lamp 31, Start Button: DOTS (2-Lug) in Cabinet under Button (RED-YEL / ORG-YEL to YEL-VIO).

Lamp 32, Tournament Button (Optional with Tournament Kit, Diode in Connector).

Go To
Diagnostics Menu





Test Flash Lamps

To initiate, from the **DIAGNOSTICS MENU**, select the "FLASH" *Icon* with either the **Red "LEFT"** or **Green "RIGHT" Buttons** and press the **Black "ENTER" Button**. After selecting this *Icon* the display will indicate **CYCLING FLASHERS**. The Flash Lamps will cycle continuously until the test is exited. This test allows the technician to easily spot any burned-out bulbs and replace them. Flashers tested are Flash Lamps in Positions: **Q1-Q32** and in this game Flash Lamp(s) are in Position(s): **Q21-Q23, Q25-Q29, Q31-Q32**.



PULL OUT the Power Interlock Switch for operation with the Coin Door open.



Clear Ball Trough

To initiate, from the **DIAGNOSTICS MENU**, select the "CLR" *Icon* with either the **Red "LEFT"** or **Green "RIGHT" Buttons** and press the **Black "ENTER" Button**. This Menu is provided to allow the technician a simple method of removing the balls from the trough and also, to test functionality of the trough, ensuring proper trough operation. After selecting this *Icon* the display will show a graphic of the ball trough with balls in the trough with it's corresponding switch number. Select the "RUN" *Mini-Icon* to eject the ball in the first position. Simultaneously, the display and the playfield will eject the ball to the Trough Up-Kicker, eject from the Trough Up-Kicker into the Shooter Lane and will be ejected onto the playfield where the technician can easily retrieve the pinball or allow the ball(s) to re-enter the trough to continue **Clear Ball Trough Test**.



PULL OUT the Power Interlock Switch for operation with the Coin Door open.

CAUTION: Continuous use of above test may overheat the Trough Up-Kicker Coil. **▲**



Technician Alerts

To initiate, from the **DIAGNOSTICS MENU**, select the "TECH" *Icon* with either the **Red "LEFT"** or **Green "RIGHT" Buttons** and press the **Black "ENTER" Button**. This Menu is provided to show any switch problems and/or missing pinballs. After selecting this *Icon*, the display will indicate *any or all* of the following categories: **POSSIBLY BROKEN SWITCH**, **CHECK SWITCHES** or **HYPER-SENSITIVE SWITCH** (Sw. #16, Shooter Lane, is used as an example). If more than one switch is reported, the Switch Number and Name will cycle within the category, and then will cycle the categories. To return to the **DIAGNOSTICS MENU**, select & *activate* the "PREV" *Mini-Icon*.



Switch Detection

During game play, activation of switches and operation of coils with associated switches are monitored. In programming, every switch is given a minimum & maximum value based on the game. The switches are monitored every 5 minutes of game play with a "sliding window" of 15 minutes. If a switch is determined to be faulty, game play is compensated. Switches noted as **POSSIBLY BROKEN SWITCH** should be checked, then adjusted or replaced. **Important:** A switch reported as "possibly broken" may actually be an unused switch due to **lack of usage and not because they're broken**. This can happen, if a switch is located in a "hard" shot position, and the players are not making the shot. Game programming will still compensate for this unplayed switch. Switches noted as **CHECK SWITCHES** are determined to be stuck closed or open depending on switch usage. Free up the switch actuator; adjust or replace if necessary. Switches noted as **HYPERSENSITIVE SWITCH** means just that, the switch should be readjusted or replace if necessary.

Determination of switch usage can be check in **Audits** (review Section 3, Chapter 3, **GO TO AUDITS MENU**). Find the associated Audit with the switch in question and check usage; compare it to commonly used switches for comparison. After any switch is checked and repaired or replaced, it's suggested to test the switch in the **PLAY TEST MENU** (see the *next page*) or **Single Coil Test** (reviewed earlier in this chapter, **Page 18**) where the associated coil to the switch can be tested as well. After correcting the problem, the switch will still be reported until the game is played and the switch is again monitored as specified above. *Only you can determine if a switch getting reported is bad or if the switch is currently not getting actuated during game play.*

Coils **are not reported** in **Technician Alerts**, however, if a faulty switch is the culprit, the switch will then be reported. This **display** is shown momentarily during **Game Mode** or **Power-Up** to alert the operator of a coil malfunction (coil doesn't energize or coil fires a multiple number of times). **OPERATOR ALERT!** works by monitoring any *switch activated coil* that has the potential to trap a ball when disabled (e.g. in the Auto Launch, Scoop, Eject, etc.). This alert can also appear if a switch associated with a coil (e.g. #16 Shooter Lane & #2 Auto Launch) is stuck closed (caused by a switch jam or stuck ball); the **CPU/Sound Board** will *activate* the coil approximately ten times and if the switch remains closed, the game will report this switch in **Technician Alerts** as **CHECK SWITCHES**. The display alert **PLEASE CHECK TECH REPORT** will be shown.



Technicians Alerts continued on the next page.

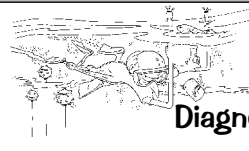



Technician Alerts Continued

While in **Technician Alerts** Menu, if the following is displayed, the game has detected 1 or more pinball(s) missing and has compensated for the lost pinball(s) to provide normal game play

PLAYFIELD STATUS
PINBALL MISSING

PREVIOUS

Important: Determine where the pinball is! **Do not add pinball(s)** until it is determined the pinball(s) are indeed missing and not just stuck. If pinball(s) are added, and if the original stuck pinball has freed itself, the pinball game will not operate properly with the extra pinball(s). When the pinball is recovered, the above display will not appear the next time **Technician Alerts** is visited (a game must be played for the pinball to be determined as found).

Pinball Detection

During game play, a ball can get trapped or stuck. If after approximately 15 seconds of inactivity or "no scoring," **Ball Search** is started. **Note:** If the pinball is in the Plunger Lane or "held" on the flipper, no **Ball Search** will be performed. The game will perform one **Ball Search** in an attempt to "find" or free-up the pinball. If the game does not see a switch closure (indicating the pinball has not been found), the following display will appear with a count-down timer of 20 seconds, during which **Ball Search** will continue until the timer runs out (*this feature will not happen if the game is in Competition Mode; Ball Search will continue until the pinball is found, unstuck and/or replaced manually*). The display will momentarily acknowledge the missing pinball(s). The game will provide another pinball into play and will compensate for the lost pinball. Game play will appear normal. **Note:** This detection and compensation will happen with every pinball, if each suffers the same fate of a ball trap. If all balls get trapped, the game cannot be played or started until the situation is rectified.

LOOKING FOR
PINBALLS
PLEASE WAIT 20

Until any missing pinball is returned to play, the game upon **Power-up**, opening the **Coin Door** or exiting **Portals™**, will continue to momentarily display the following (along with an audible sound):

PLEASE CHECK
TECH REPORT
PORTALS->DIAG->TECH



Service Phone

To initiate, from the **DIAGNOSTICS MENU**, select the "SERV" *Icon* with either the Red "LEFT" or Green "RIGHT" **Buttons** and press the Black "ENTER" **Button**. After selecting this *Icon* the display will indicate a phone number to call if technical assistance is required (*In USA Code: 1-800-KICKERS*).



Begin Play Test

To initiate, from the **DIAGNOSTICS MENU**, select the "PLAY" *Icon* with either the Red "LEFT" or Green "RIGHT" **Buttons** and press the Black "ENTER" **Button**. After selecting this *Icon* the technician can test certain play functions to insure all switch activated coils function without entering game play. For example, by rolling the ball over the Shooter Lane switch, the Autoplunger should fire. If it kicks too early or too late, the switch actuator should be adjusted to compensate for this error. If it fails to fire, use the **Switch Test** or **Coil Test** to help determine the cause of the failure. During this function, similar tests may be performed on the "Ejects", Slingshots, Vertical Up-Kickers, Pop Bumpers, etc. in the game. For unique Play Test functions, select the **TV TEST** *Icon* in the **DIAGNOSTICS MENU**.

COIN DOOR IS OPEN
PLAYFIELD HIGH POWER
DISABLED BY
COIN DOOR INTERLOCK

PULL OUT the Power Interlock Switch for operation with the Coin Door open.



Fire Knocker

To initiate, from the **DIAGNOSTICS MENU**, select the "KNOCKER" *Icon* with either the Red "LEFT" or Green "RIGHT" **Buttons** and press the Black "ENTER" **Button**. The digitally mastered "Knocker" is sounded.



Sound / Speaker Test

To initiate, from the **DIAGNOSTICS MENU**, select the "SPKR" *Icon* with either the Red "LEFT" or Green "RIGHT" **Buttons** and press the Black "ENTER" **Button**. The BSMT 2000 Sound System produces true digital stereo sound from Backbox & Cabinet Speakers or "Mono" on the Cabinet Speaker (when used by itself). After selecting this *Icon*, select the "-" or "+" *Mini-Icons* and press the Black "ENTER" **Button** to activate the first test. Repeat to visually see & hear all tests. Select the "RUN" *Mini-Icon* to activate the test chosen without moving to the next test.

Note: During Sound Tests, the display shows the speaker identification and the corresponding sound(s). The sound functions allow verification that both channels are functioning properly & that the speaker connections are correct.



Sound / Speaker Test continued on the next page.

Go To
Diagnostics Menu



Section 3, Chapter 2
Page 25



Sound / Speaker Test Continued

Speaker Phase Testing

Connections to each of speakers are polarized and each must be connected appropriately for the best quality sound. If one speaker has the positive and negative connections reversed with respect to the other one, bass frequencies will not be produced properly and the overall sound quality will be poor. To test for proper speaker phasing, use the sound test to cycle through the Backbox & Cabinet, and Backbox Sine (repeated) functions. If the Cabinet Sine produces more volume and bass than the Left Sine, the speakers are connected properly. If it produces the same or less, one speaker is connected improperly. To isolate and correct reversed speaker connections, one of two methods may be used.

1. Check each speaker for polarity markings. If the speakers have polarity markings, verify that the Backbox Speaker **RED-WHT** Wire and the Cabinet Speaker **YEL-WHT** Wire is connected to the negative (-) terminal.
2. Disconnect the speaker output connector from the CPU / Sound Board and connect a 1.5-volt battery across each speaker pair one at a time while observing the speakers. Make sure the positive battery terminal is connected to the positive lead (CN4, Pin-3 (**RED-BLK**) or Pin-6 (**YEL-BLK**)) each time. As the connection is made, check speaker cone movement; proper connections are indicated by outward movement.

Auto / Manual Tests	Sounds Produced
Speaker Test	Tone
Sound/OPSYS EPROM (Loc. U7)	Level 1-3+ (Music Test)
Voice ROMs: 1 (U17) 2 (U21) 3 (U36) 4 (U37)	Speech Pattern 1-3+

Note: For ROM Usage (Summary Table) & Locations, see Page DR. ❶ in the "Find-It-In-Front: Dr. Pinball Section". Voice ROMs (U17, U21, U36 and/or U37) which are 8MB must have a Jumper at W6 on the CPU/Sound Board to function properly.



Begin Burn In

To initiate, from the **DIAGNOSTICS MENU**, select the "BURN" *Icon* with either the **Red "LEFT"** or **Green "RIGHT" Buttons** and press the **Black "ENTER" Button**. After selecting this *Icon* the **Begin Burn-In Test** will start. At this stage the game will exercise all CPU I/O Functions (**Dot Matrix Display Test, Coil Testing, Lamp Testing, Sound...**, etc.). This is provided to constantly exercise sounds, coils, etc... Cumulative Burn-In minutes will be displayed. **Note:** To reset Burn-In minutes to **00** see Section 3, Chapter 6, **GO TO RESET MENU, Factory Reset**. **Caution:** Performing a Factory Reset will reset all other information as well.



Dot Matrix Test

To initiate, from the **DIAGNOSTICS MENU**, select the "DOT TEST" *Icon* with either the **Red "LEFT"** or **Green "RIGHT" Buttons** and press the **Black "ENTER" Button**. After selecting this *Icon* the **Dot Matrix Test** immediately begins. The display will immediately illuminate & cycle for 1 pass of each test continuously for each of the following tests:

1. Illuminates 1 vertical column of dots, turning it off & illuminating the next column, until each column has been individually lit, while the other columns are off.
2. Illuminates 1 horizontal row of dots, turning it off & illuminating the next row, until each row has been individually lit, while the other rows are off.
3. Illuminates all the dots, except for one column from left to right.
4. Illuminates all the dots, except for one row from top to bottom.
5. Illuminates every other dot lit, in both the rows and columns.

Note: Pressing any button will exit the test & return to **DIAGNOSTICS MENU**.

Dot Matrix Display Explained

The display utilizes a **Micro-Processor Control Board** mounted in piggyback fashion to the **Dot Matrix Display (128 X 32) Driver Board**. The purpose behind this board is to provide more information to the operator as well as displaying graphics to the player.

The board is controlled by a **6809E Microprocessor** and its personality ROM (Unique to the Game). It receives Data, Reset & Clock Information from the **CPU/Sound Board** via the ribbon cable and sends back multiple Status and Busy Signals to the **CPU**. This is to insure synchronized communication between the **CPU** and the **Display Controller Board**. The Drivers for the rows and columns are provided on 5 surface mounted integrated circuits on the **Dot Matrix Display Driver Board**.





LED Test

NOTE: Upon Power-Up, entering the **Portals™ Service Menu**, or exiting this test, the "TV" will display the word **TEST** and 3 '4x4' Squares (Red, Yellow and Green).

To initiate, from the **DIAGNOSTICS MENU**, select the "TV" Icon with either the **Red "LEFT"** or **Green "RIGHT" Buttons** & press the **Black "ENTER" Button**. The **LED TEST MENU** appears with the "+" Mini-Icon flashing. This test is provided to allow a method of testing the combined 4 "5X7 Color Dot Displays" in the "TV Set" on the *Upper Playfield*. Upon entering the **LED TEST MENU**, the first Test Menu "**ALL OFF**" appears and the TV Set LEDs are shut off.

Select and activate either of the "-" or "+" Mini-Icons to change any of the **eight (8) LED Tests** (as shown below). As each Test Menu appears, the name of the test will appear in the Main Dot Matrix Display (128 X 32) with the corresponding test demonstrated in the "TV Set." The **LED Test** selected will cycle continuously until the next or previous test is chosen, or if the Test Menu is exited.

The first four (4) of the eight (8) LED Test Menus are:

1:

LED TEST

ALL OFF

[-] [+] PREV QUIT [?]

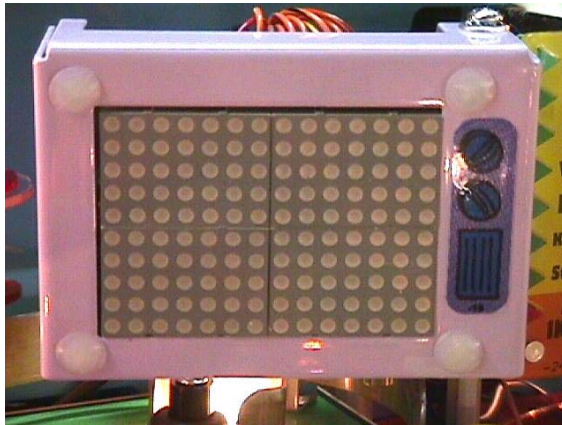

2:

LED TEST

VERTICAL LINE

[-] [+] PREV QUIT [?]

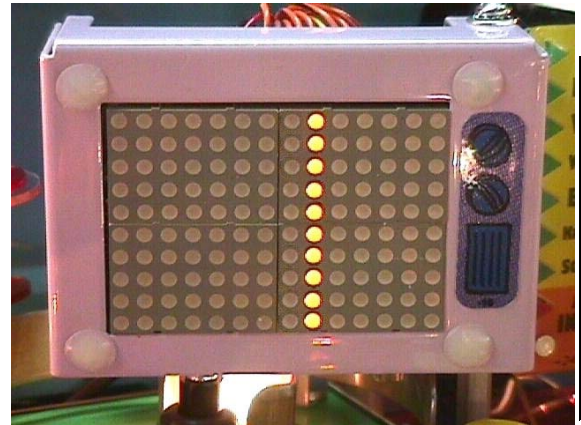

3:

LED TEST

HORIZONTAL LINE

[-] [+] PREV QUIT [?]

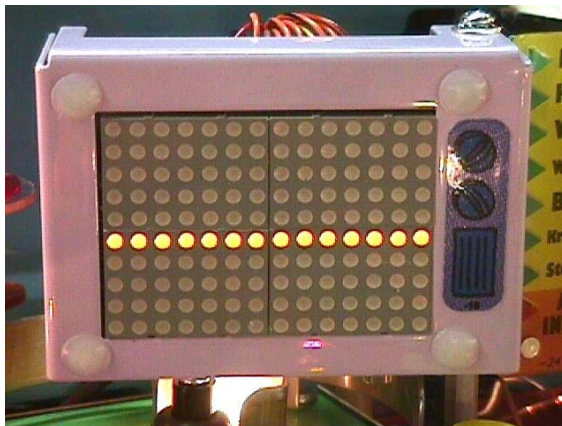

4:

LED TEST

REVERSE VERTICAL LINE

[-] [+] PREV QUIT [?]

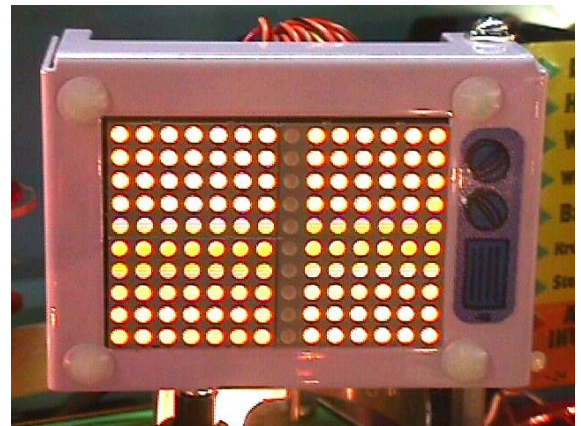

Sec. 3: ... Diagnostics

LED Test Menus 5-8 continued on the next page.

Go To
Diagnostics Menu

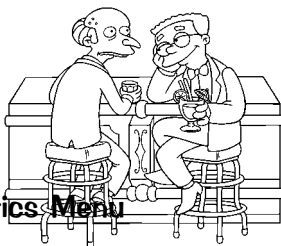



LED Test Continued

The next four (4) of the eight (8) LED Test Menus are:

5: LED TEST
REV. HORIZONTAL LINE
 - + PREV QUIT



6: LED TEST
ALL YEL
 - + PREV QUIT



7: LED TEST
ALL RED
 - + PREV QUIT



8: LED TEST
ALL GRN
 - + PREV QUIT

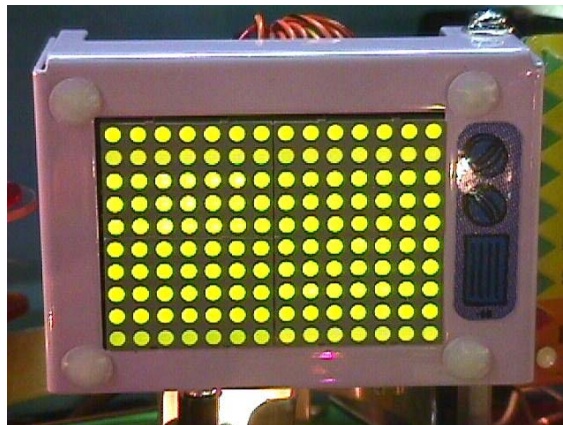

Sec. 3: ... Diagnostics

Select the "PREV" Mini-Icon to return to the **DIAGNOSTICS MENU** or select "QUIT" Mini-Icon to exit **Portals™**. If any of the tests do not perform correctly, call Technical Support for diagnosing or troubleshooting.

Note: For more details on the Color Dot Display (5X7) x4 PC Board or the LED PC Bd., see Sec. 5, Chapter 4, **Printed Circuit Boards (PCBs)**, Pages **140-143**.

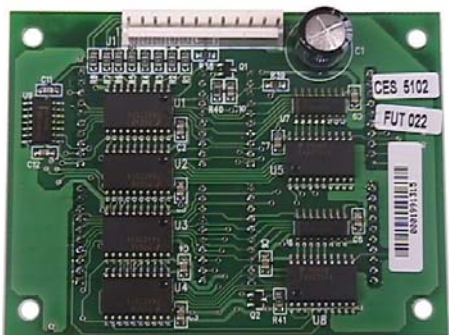

To test the LEDs on the Mode Sign, enter the "Go To Lamp Menu" and select "Single Lamp Test."

These LEDs are **Lamps 73-80** in the Lamp Matrix, Page 22.





Go To Fuse Table

To initiate, from the **DIAGNOSTICS MENU**, select the "FUSES" *Icon* with either the Red "LEFT" or Green "RIGHT" Buttons and press the Black "ENTER" Button. The **FUSE TABLE MENU** now appears. This provides the technician with the current **Fuse Table** for this game (*also noted on decal in the Backbox*). The fuses are located in the Backbox (*on the Display Power Supply Board and the I/O Power Driver Board*), and also in the Cabinet (*under the playfield by the Flippers and/or by any unique assembly requiring an additional fuse, such as magnets*). For the complete **Fuse List** in the *Quick Reference Fuse Chart & Pictorials*, see the next page or Page DR. ❶ (*front of this manual*).

Example:

After entering **Portals™**, the **MAIN MENU** now appears with the "DIAG" *Icon* (GO TO DIAGNOSTICS MENU) flashing:



Press the Black "ENTER" Button to *activate* this **ICON**. The **DIAGNOSTICS MENU** now appears with the "SW" *Icon* (GO TO SWITCH MENU) flashing; use the Red "LEFT" or Green "RIGHT" Buttons, until the "FUSES" *Icon* (GO TO FUSE TABLE) is flashing:

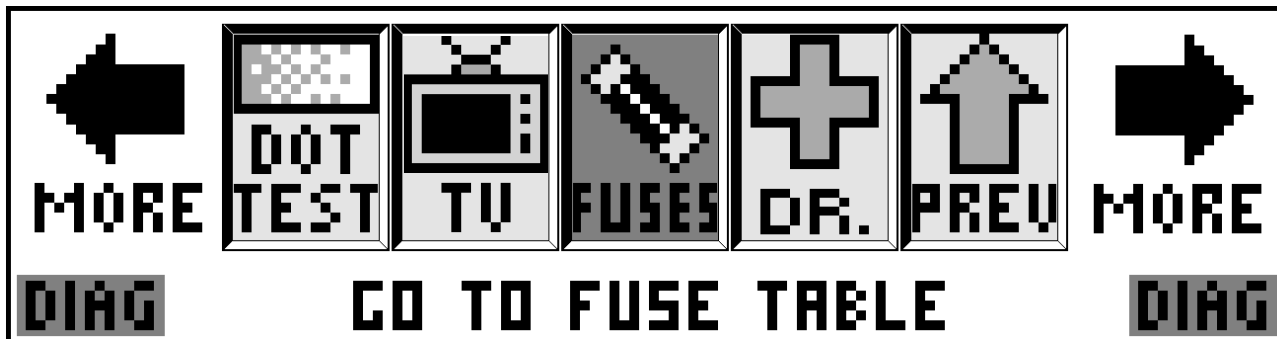

Press the Black Button to *activate* this **ICON**. The **FUSE TABLE** now appears.

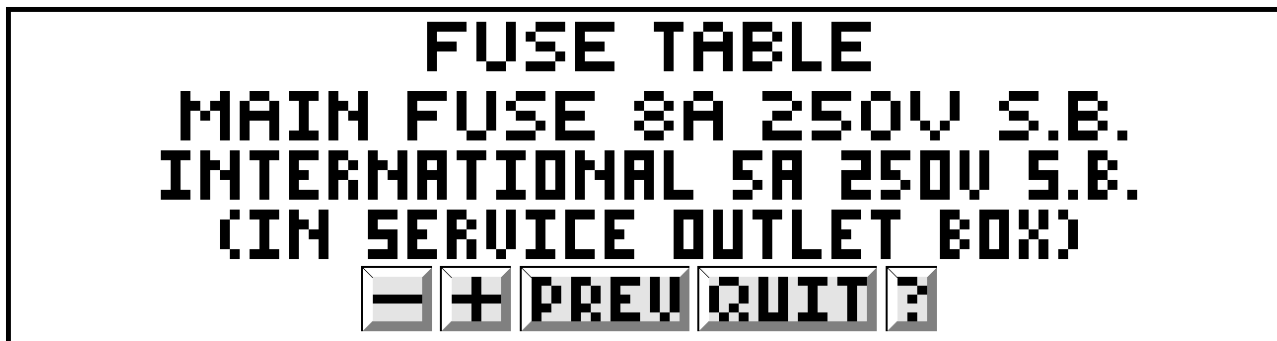

Select and *activate* the "+" *Mini-Icon* to view the next fuse in the group. Continue to select either the "+" or "-" *Mini-Icons* to view each fuse one at a time. The display will describe the fuse identification number (e.g. Main, F1, F6, F7, etc.), rating of fuse (e.g. 5A 250v S.B. - i.e. 5 Amp, 250 volt, Slo-Blo), location of fuse (i.e. Backbox: Board Name located on; or Cabinet: Under the playfield or in Service Outlet), and 'use of fuse' (e.g. 90v DC High Voltage Power, etc.). The current fuse listed will remain in the display until the next fuse is chosen or when the Sub-Menu is exited by selecting & *activating* the "PREV" or "QUIT" *Mini-Icons*.

Go To Fuse Table continued on the next page.



Backbox PCB Fuses, ROMs, Bridges, Relays, P/F & Cabinet Fuses, Cab. Switches

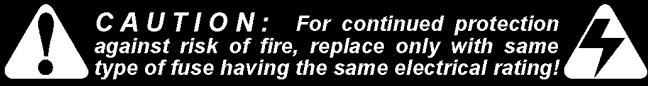

QUICK REFERENCE FUSE CHART

Backbox Fuses

LOC: DISPLAY POWER SUPPLY (P.S.) BOARD			
F1	3/4A 250v S.B.	90v DC	High Voltage Display
LOC: I / O POWER DRIVER BOARD			
F6	7A 250v S.B.	50v DC	Primary High Power Coils/Flippers
F7	5A 250v S.B.	20v DC	Low Power Coils
F8	5A 250v S.B.	12v DC	Logic Power
F9	5A 250v S.B.	12v DC	Logic Power
F20	3A 250v S.B.	50v DC	Magnet(s)/Auxilliary NOT USED
F21	3A 250v S.B.	50v DC	Coils
F22	8A 250v S.B.	18v DC	Controlled Lamps
F23	4A 250v S.B.	5v DC	Logic
F24	5A 250v S.B.	6.3v AC	G.I. Lamps (BRN-WHT to WHT-BRN)
F25	5A 250v S.B.	6.3v AC	G.I. Lamps (YEL to WHT-YEL)
F26	5A 250v S.B.	6.3v AC	G.I. Lamps (GRN to WHT-GRN)
F27	5A 250v S.B.	6.3v AC	G.I. Lamps (VIO to WHT-VIO)
F28	3A 250v S.B.	24v AC	Not Used / Spare

Cabinet Fuses

LOC: SERVICE (AC) OUTLET BOX (Cabinet Bottom)			
n/a	8A 250v S.B.	115v AC	Main Fuse Line (Domestic or USA)
n/a	5A 250v S.B.	220v AC	Main Fuse Line (International)

Playfield (P/F) Fuses

LOC: UNDER PLAYFIELD (near Flippers)			
n/a	3A 250v S.B.	50v DC	Rt. & Upr. Rt. Flips (BLU-YEL↔RED-YEL)
n/a	3A 250v S.B.	50v DC	Left Flipper (GRY-YEL↔RED-YEL)
n/a	3A 250v S.B.	50v DC	Upr. P/F Rt. Flip. (BLU-YEL↔RED-YEL)
n/a	3A 250v S.B.	50v DC	Upr. P/F Lt. Flip. (GRY↔RED-YEL)

For locations & more information on fuses, see Sec. 5, Chapter 2.

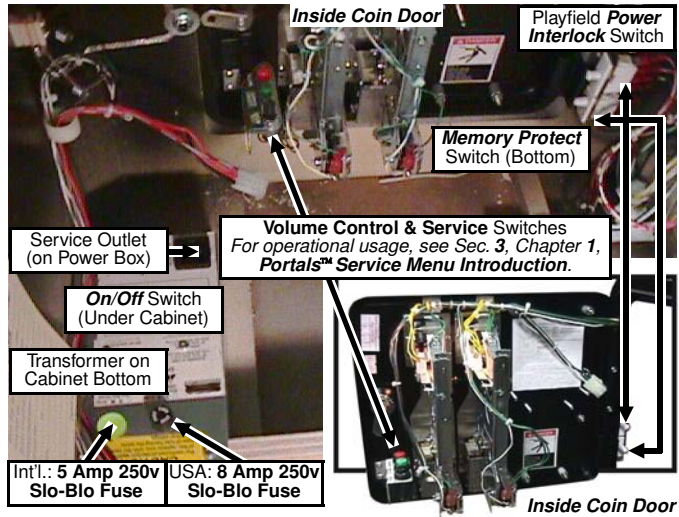

ROM TYPE on BD	LOCATION	SIZE	PART NUMBER
CPU Sound	U7	512K	965-0381-77
CPU Game	U210	1 MB	965-0382-77
CPU Voice ROM 1	U17	8 MB	965-0383-77
CPU Voice ROM 2	U21	8 MB	965-0384-77
CPU Voice ROM 3	U36	8 MB	965-0385-77
CPU Voice ROM 4	U37	8 MB	965-0386-77
DISPLAY Controller	U5	4 MB	965-0387-77

Sec. 3: ... Diagnostics

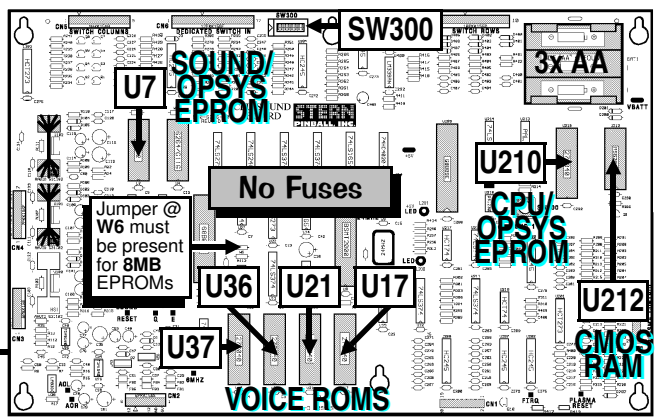
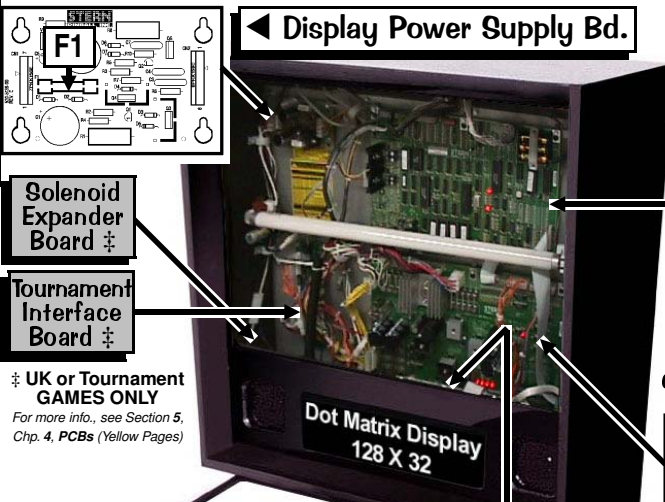

For Schematics and/or Component Parts on PC Boards shown on this page, review Section 5, Chapter 4, Printed Circuit Boards (The Yellow Pages).

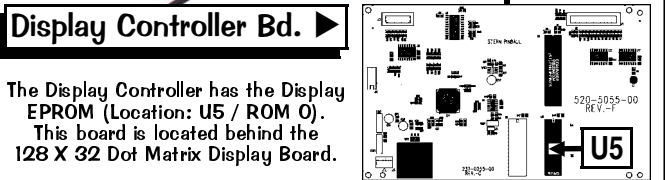

The Display Controller has the Display EPROM (Location: U5 / ROM 0). This board is located behind the 128 X 32 Dot Matrix Display Board.

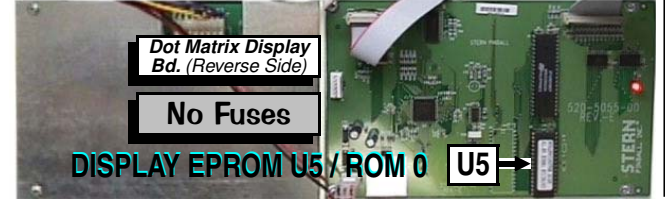
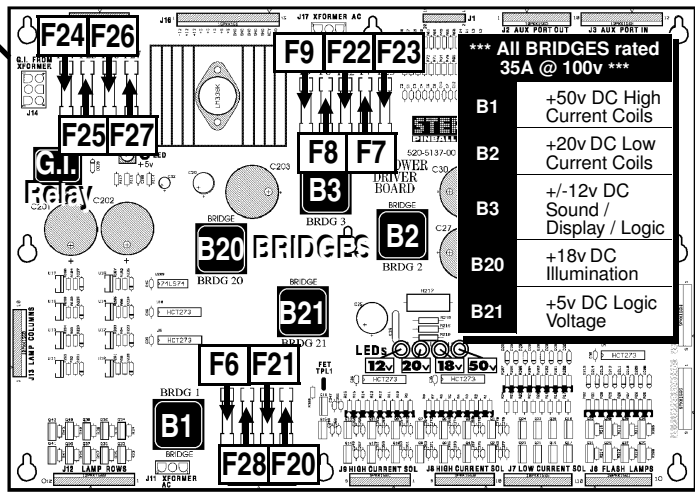



Dr. Pinball

To initiate, from the **DIAGNOSTICS MENU**, select the Cross "DR." *Icon* with either the **Red "LEFT"** or **Green "RIGHT" Buttons** and press the **Black "ENTER" Button**. This will bring you (the operator / technician) into **DR. PINBALL (Flow Chart Menus)** which offers you a choice of three (3) *Icons*: Coil "DR.", Switch "DR." and Lamp "DR." *Icons*. Selecting a particular *Icon* will give you a choice of which specific Coil (*any and all coil assemblies such as Flippers, VUKs, Magnets, etc.*), Switch or Lamp circuit needs to be diagnosed. *Dr. Pinball* will now display a question or give a procedure to follow such as "Does the lamp turn on?" or "Check bridge rectifier BR-20, if short replace." When *Dr. Pinball* displays a question or requests a procedure, *Dr. Pinball* will expect a response such as "NO" or "YES" (*see below examples of the Mini-Icons* which will prompt the operator). You the operator/technician must respond by using the **Red or Green Buttons** to "SELECT" a *Mini-Icon* and the **Black Button** to "ACTIVATE or ENTER" your selection.



Coil Flow Chart

To initiate, from the **DR. PINBALL MENU**, select the Coil "DR." *Icon* with either the **Red or Green Buttons** and press the **Black Button**. This is the **Coil Flow Chart**. Follow the questions, answering by using the *Mini-Icons* in the display.



Switch Flow Chart

To initiate, from the **DR. PINBALL MENU**, select the Switch "DR." *Icon* with either the **Red or Green Buttons** and press the **Black Button**. This is the **Switch Flow Chart**. Follow the questions, answering by using the *Mini-Icons* in the display.



Lamp Flow Chart

To initiate, from the **DR. PINBALL MENU**, select the Lamp "DR." *Icon* with either the **Red or Green Buttons** and press the **Black Button**. This is the **Lamp Flow Chart**. Follow the questions, answering by using the *Mini-Icons* in the display.

The following are the *Mini-Icons* with explanations for the **DR. PINBALL** Sub-Menus:



Select and *activate* either the "-" or "+" *Mini-Icons* to diagnose a Coil, Lamp or Switch. Select and *activate* the "RUN" *Mini-Icon* to test selected item. The "PREV" *Mini-Icon* allows you to go back to previous question. Select the "QUIT" *Mini-Icon* to exit **Portals™** completely. Select the "?" *Mini-Icon* (Help) to see directions on button usage.



Select and *activate* either the "NO" or "YES" *Mini-Icons* to answer a question given. Select and *activate* the "END" *Mini-Icon* to change to a new item to test. The "PREV" *Mini-Icon* allows you to go back to previous question. Select the "QUIT" *Mini-Icon* to exit **Portals™** completely. Select the "?" *Mini-Icon* (Help) to see directions on button usage.



After a diagnosis is given, select and *activate* the "END" *Mini-Icon* to change to a new item to test. The "PREV" *Mini-Icon* allows you to go back to previous display. Select the "QUIT" *Mini-Icon* to exit **Portals™** completely. Select the "?" *Mini-Icon* (Help) to see directions on button usage.



In **COIL FLOW CHART MENU**, select and *activate* the "PULSE" *Mini-Icon* to pulse the coil selected. Select and *activate* the "END" *Mini-Icon* to change to a new item to test. The "PREV" *Mini-Icon* allows you to go back to previous question. Select the "QUIT" *Mini-Icon* to exit **Portals™** completely. Select the "?" *Mini-Icon* (Help) to see directions on button usage.



STARTING METER Reading :

STARTING METER Date (MM/DD/YR) :

AUDITOR'S NAME :

CURRENT VOLUME SETTING:

CURRENT METER Reading :

AUDIT Date (MM/DD/YR) :

CPU Version :

DISPLAY Version :

GAME LOCATION NAME :

EARNINGS & STANDARD AUDIT TABLES

MAIN GO TO AUDITS MENU MAIN AUD EARNINGS AUDITS AUD

EARNINGS AUDITS 01-14

Audit definitions follow in this Chapter.

01	TOTAL PAID CREDITS	06	COINS THRU RIGHT SLOT	11	TOTAL COINS
02	FREE GAME PERCENTAGE	07	COINS THRU CENTER SLOT	12	TOTAL EARNINGS
03	AVERAGE BALL TIME	08	COINS THRU 4TH SLOT	13	METER CLICKS
04	AVERAGE GAME TIME	09	COINS THRU 5TH SLOT	14	SOFTWARE METER
05	COINS THRU LEFT SLOT	10	COINS THRU 6TH SLOT		

MAIN GO TO AUDITS MENU MAIN AUD STANDARD AUDITS AUD

STANDARD AUDITS 01-67

Audit definitions follow in this Chapter.
To track Feature & Tournament Audits, see Pages 36 or 54.

01	TOTAL BALLS PLAYED	25	12.5M - 15M SCORES	49	PROPRIETARY
02	TOTAL EXTRA BALLS	26	15M - 20M SCORES	50	BASE REPLAY
03	EXTRA BALL PERCENT	27	20M - 30M SCORES	51	LEFT FLIPPER USED
04	REPLAY 1 AWARDS	28	30M - 50M SCORES	52	RIGHT FLIPPER USED
05	REPLAY 2+ AWARDS	29	50M - 75M SCORES	53	PROPRIETARY
06	TOTAL REPLAYS	30	75M - 100M SCORES	54	PROPRIETARY
07	REPLAY PERCENT	31	100M+ SCORES	55	0 - 1 MINUTE GAMES
08	TOTAL SPECIALS	32	AVERAGE SCORES	56	1 - 1.5 MINUTE GAMES
09	SPECIAL PERCENT	33	SERVICE CREDITS	57	1.5 - 2 MINUTE GAMES
10	TOTAL MATCHES	34	BALL SEARCH STARTED	58	2 - 2.5 MINUTE GAMES
11	HIGH SCORE AWARDS	35	LOST BALL FEEDS	59	2.5 - 3 MINUTE GAMES
12	HIGH SCORE PERCENT	36	LOST BALL GAME STARTS	60	3 - 3.5 MINUTE GAMES
13	TOTAL FREE PLAYS	37	LEFT DRAINS	61	3.5 - 4 MINUTE GAMES
14	TOTAL PLAYS	38	CENTER DRAINS	62	4 - 5 MINUTE GAMES
15	0 - 2M SCORES	39	RIGHT DRAINS	63	5 - 6 MINUTE GAMES
16	2M - 3M SCORES	40	TILTS	64	6 - 8 MINUTE GAMES
17	3M - 4M SCORES	41	TOTAL BALLS SAVED	65	8 - 10 MINUTE GAMES
18	4M - 5M SCORES	42	PROPRIETARY	66	10 - 15 MINUTE GAMES
19	5M - 6M SCORES	43	PROPRIETARY	67	15+ MINUTE GAMES
20	6M - 7M SCORES	44	PROPRIETARY		
21	7M - 8M SCORES	45	PROPRIETARY		
22	8M - 9M SCORES	46	PROPRIETARY		
23	9M - 10M SCORES	47	PROPRIETARY		
24	10M - 12.5M SCORES	48	PROPRIETARY		



Go To Audits Menu

Overview

The Portals™ Service Menu System provides **246** Audits for accounting purposes and for evaluation of *Game Programming*. The Audits are divided into 3 groups: • **Earnings Audits** (Audits **01-14**), • **Standard Audits** (Audits **01-67**) and • **Feature Audits (Programming Use Only)** (Audits **01-165**). For details on **Tournament Audits**, see Section 3, Chapter 7, **GO TO TOURNAMENT MENU**. Audits which are named **Proprietary** are also for **Future Expansion or Programming**. Game code may get upgraded during production; compare all Audits in the display with the manual and make any corrections to the Audit Table (*previous page*), as necessary. Audits are subject to change (with or without notice). To view Audits in the display, enter the **Portals™ Service Menu System**. For how to **RESET** Audits, see Section 3, Chapter 6, **GO TO RESET MENU**.



EXPLANATION & USAGE OF COMMON LARGE & MINI-ICONS USED IN VARIOUS MENUS & SUB-MENUS:



These *non-selectable* icons appear in the selected Menu only when there are MORE icons to the LEFT or to the RIGHT available for selection.



Select and activate to return to the PREVIOUS Menu.



Select and activate to QUIT, exits & returns to the Attract Mode.



Select and activate to view HELP Screens of the current Menu*.



Move LEFT or RIGHT, select previous / next or move backwards / forwards.

* Help Note: An explanation of each Mini-Icon at that menu level will cycle continuously. To exit a display where no Mini-Icons are available for selection, pressing any button will exit the display.



GO TO AUDITS MENU

After entering **Portals™**, the **MAIN MENU** now appears. Select the "AUD" *Icon* in the **MAIN MENU** with either the **Red "LEFT"** or **Green "RIGHT"** Buttons (the **Flipper Buttons** operates in the same manner) and press the **Black "ENTER"** Button (the **Start Button** operates in the same manner). The **AUDITS MENU** appears. Continue through this chapter for the explanation & usage of the *Icons* in the **AUDITS MENU**.



Earnings Audits (01-14)

To initiate, from the **AUDITS MENU**, select the "EARN" *Icon* with either the **Red "LEFT"** or **Green "RIGHT"** Buttons and press the **Black "ENTER"** Button. Select and *activate* either of the ">>" *Mini-Icons* to view the next or previous Audit in this group. The display will describe the **Audit Number**, **Audit Name** and the **Current Audit Total** (Value). The current Audit will remain in the display until the next Audit is viewed or when this Menu is exited.

Nr.	EARNINGS AUDIT NAME: Definition
01	TOTAL PAID CREDITS: Provides the total number of <i>Paid Credits</i> .
02	FREE GAME PERCENTAGE: Provides the percentage total by dividing Standard Audit 13, TOTAL FREE PLAYS , by Standard Audit 14, TOTAL PLAYS .
03	AVERAGE BALL TIME: In seconds, the average ball time is derived from the total play time divided by Standard Audit 01, TOTAL BALLS PLAYED .
04	AVERAGE GAME TIME: The average game time is expressed in minutes and seconds (0:00).
05	COINS THRU LEFT SLOT: Provides the total number of times Coin Mechanism Switch 06 was closed.
06	COINS THRU RIGHT SLOT: Provides the total number of times Coin Mechanism Switch 04 was closed.
07	COINS THRU CENTER SLOT: Provides the total number of times Coin Mechanism Switch 05 was closed.
08	COINS THRU 4TH SLOT: Provides the total number of times Coin Mechanism Switch 02 was closed.
09	COINS THRU 5TH SLOT: Provides the total number of times Coin Mechanism Switch 07 was closed.
10	COINS THRU 6TH SLOT: Provides the total number of times Coin Mechanism Switch 03 was closed.
11	TOTAL COINS: Provides the total amount of coins registered through all the <i>Coin Slots</i> .
12	TOTAL EARNINGS: The total cash value accumulated since the last Factory Reset occurred. See Section 3, Chapter 6, GO TO RESET MENU , Reset Coin Audits .
13	METER CLICKS: Provides the total number of money clicks accumulated. <i>Based on the country's lowest coin denomination used for the game credit.</i>
14	SOFTWARE METER: Provides the continuing total of Meter Clicks. <i>This audit cannot be reset; the display shows the constant addition of Meter Clicks.</i>

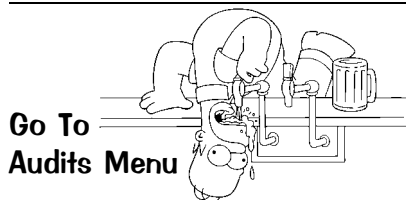



Standard Audits (01-67)

To initiate, from the **AUDITS MENU**, select the "S.P.I." *Icon* with either the **Red "LEFT"** or **Green "RIGHT" Buttons** and press the **Black "ENTER" Button**. Select and *activate* either of the ">>" *Mini-Icons* to view the next or previous Audit in this group. The display will describe the **Audit Number**, **Audit Name** and the **Current Audit Total** (Value). The current Audit will remain in the display until the next Audit is viewed or when this Menu is exited.

Nr.	STANDARD AUDIT NAME: Definition
01	TOTAL BALLS PLAYED: Provides the total number of <i>Regular</i> and <i>Extra Balls</i> .
02	TOTAL EXTRA BALLS: Provides the total number of <i>Extra Balls</i> awarded.
03	EXTRA BALLS PERCENT: Provides the percentage total by dividing Standard Audit 02, TOTAL EXTRA BALLS , by Standard Audit 14, TOTAL PLAYS .
04	REPLAY 1 AWARDS: Provides the total <i>Awards (Credits, Extra Balls or Scores)</i> for Level 1.
05	REPLAY 2+ AWARDS: Provides the total <i>Awards (Credits, Extra Balls or Scores)</i> for Level 2 or higher.
06	TOTAL REPLAYS: Provides the total <i>Awards (Credits, Extra Balls or Scores)</i> for exceeding <i>Replay Score Levels</i> .
07	REPLAY PERCENT: Provides the percentage total from dividing Standard Audit 06, TOTAL REPLAYS , by Standard Audit 14, TOTAL PLAYS . The percentage reflects replay total awards for exceeding replay score levels.
08	TOTAL SPECIALS: Provides the total <i>Awards (Credits, Extra Balls, or Scores)</i> for making <i>Specials</i> .
09	SPECIAL PERCENT: Provides the percentage total by dividing Standard Audit 08, TOTAL SPECIALS , by Standard Audit 14, TOTAL PLAYS .
10	TOTAL MATCHES: Provides the total <i>Credits</i> awarded for matching the last two digits of the score with the <i>System-Generated Match Number</i> at the end of the game. Percentage of <i>Match Credits</i> is adjustable from 0% to 10% by Standard Adjustment 13, MATCH PERCENTAGE , if enabled. See Section 3, Chapter 4, GO TO ADJUSTMENTS MENU, Standard Adjustments .
11	HIGH SCORE AWARDS: Provides the total <i>Awards (Credits, Extra Balls, or Scores)</i> for exceeding the <i>High-Score-To-Date</i> scores.
12	HIGH SCORE PERCENT: Provides the percentage total by dividing Standard Audit 11, HIGH SCORE AWARDS , by Standard Audit 14, TOTAL PLAYS .
13	TOTAL FREE PLAYS: Provides the total <i>Free Credits</i> for <i>Replays, High-Score-To-Date, Specials and Match</i> .
14	TOTAL PLAYS: This total is derived by adding the sum of Earnings Audit 01, TOTAL PAID CREDITS , and Standard Audit 13, TOTAL FREE PLAYS . <i>Note: Free Credits are not recorded in the Audit until they are actually used.</i>
15	0 - 2M SCORES: Provides the total number of games the Player's final score was 0 and 1,999,990 points.
16	2M - 3M SCORES: ... and the Player's final score was between 2,000,000 and 2,999,990 points.
17	3M - 4M SCORES: ... and the Player's final score was between 3,000,000 and 3,999,990 points.
18	4M - 5M SCORES: ... and the Player's final score was between 4,000,000 and 4,999,990 points.
19	5M - 6M SCORES: ... and the Player's final score was between 5,500,000 and 5,999,990 points.
20	6M - 7M SCORES: ... and the Player's final score was between 6,000,000 and 6,999,990 points.
21	7M - 8M SCORES: ... and the Player's final score was between 7,000,000 and 7,999,990 points.
22	8M - 9M SCORES: ... and the Player's final score was between 8,000,000 and 8,999,990 points.
23	9M - 10M SCORES: ... and the Player's final score was between 9,000,000 and 9,999,990 points.
24	10M - 12.5M SCORES: ... and the Player's final score was between 10,000,000 and 12,499,990 points.
25	12.5M - 15M SCORES: ... and the Player's final score was between 12,500,000 and 14,999,990 points.
26	15M - 20M SCORES: ... and the Player's final score was between 15,000,000 and 19,999,990 points.
27	20M - 30M SCORES: ... and the Player's final score was between 20,000,000 and 29,999,990 points.
28	30M - 50M SCORES: ... and the Player's final score was between 30,000,000 and 49,999,990 points.
29	50M - 75M SCORES: ... and the Player's final score was between 50,000,000 and 74,999,990 points.
30	75M - 100M SCORES: ... and the Player's final score was between 75,000,000 and 99,999,990 points.
31	100M+ SCORES: Provides the total number of games the Player's final score was 100,000,000 points and over.
32	AVERAGE SCORES: This total is derived from adding the <i>Final Score</i> of each game to a table and dividing this sum by Standard Audit 14, TOTAL PLAYS .

Sec. 3: Go To Audits

Standard Audits 33-67 continued on the next page.

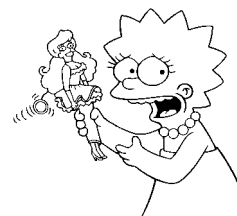



- 33 **SERVICE CREDITS:** Provides the total number of times the **Portals™ Green Button** (Dedicated Switch 7) was pushed in **Attract Mode**.
See Section 3, Chapter 1, Service Switch Set Access & Use, for how to receive Service Credits.
See Sec. 3, Chp. 6, GO TO RESET MENU, Reset Credits, for how to delete Service (and Paid Credits).
- 34 **BALL SEARCH STARTED:** Provides the total number of times the game performed a **Ball Search**.
- 35 **LOST BALL FEEDS:** Provides the total number of times the game added a pinball to play when it could not find a pinball after **Ball Search**.
See Section 3, Chapter 2, GO TO DIAGNOSTICS MENU, Technicians Alert [Pinball Detection].
- 36 **LOST BALL GAME STARTS:** Provides the total number of times the game started with a pinball missing from the ball trough at the start of a game.
See Section 3, Chapter 2, GO TO DIAGNOSTICS MENU, Technicians Alert [Pinball Detection].
- 37 **LEFT DRAINS:** Provides the total number of times Rollover Switch 57 was closed.
- 38 **CENTER DRAINS:** Provides the total number of times the pinball had drained when the last switch closed was not Switch 57 or Switch 60.
- 39 **RIGHT DRAINS:** Provides the total number of times Rollover Switch 60 was closed.
- 40 **TILTS:** Provides the total number of times Contact Switch 56 was closed.
- 41 **TOTAL BALLS SAVED:** Provides the total number of times this feature was used (*this feature can be turned ON or OFF, see Standard Adj. 38, FREEZE TIME in Section 3, Chapter 4, GO TO ADJUSTMENTS MENU, Standard Adjustments*). This feature is enabled at the start of each pinball and is disabled as soon as a predetermined number of switches are "closed" **or** the allocated time has expired.
- >> 42 - 49 **PROPRIETARY:** Proprietary Audits are used for **Future Expansion** or **Programming**.
- 50 **BASE REPLAY:** Provides the current base **Replay Level Score**.
- 51 **LEFT FLIPPER USED:** Provides the total number of times the **Left Flipper Button** (Dedicated Switch 1) was pushed in **Game Mode**.
- 52 **RIGHT FLIPPER USED:** Provides the total number of times the **Right Flipper Button** (Dedicated Switch 3) was pushed in **Game Mode**.
- >> 53 - 54 **PROPRIETARY:** Proprietary Audits are used for **Future Expansion** or **Programming**.
- 55 **0 - 1 MINUTE GAMES:** Provides the total number of games the total game time was between **0:00** and **1:00** minute.
- 56 **1 - 1.5 MINUTE GAMES:** Provides the total number of games the total game time was between **1:00** and **1:30** minutes.
- 57 **1.5 - 2 MINUTE GAMES:** Provides the total number of games the total game time was between **1:30** and **2:00** minutes.
- 58 **2 - 2.5 MINUTE GAMES:** Provides the total number of games the total game time was between **2:00** and **2:30** minutes.
- 59 **2.5 - 3 MINUTE GAMES:** Provides the total number of games the total game time was between **2:30** and **3:00** minutes.
- 60 **3 - 3.5 MINUTE GAMES:** Provides the total number of games the total game time was between **3:00** and **3:30** minutes.
- 61 **3.5 - 4 MINUTE GAMES:** Provides the total number of games the total game time was between **3:30** and **4:00** minutes.
- 62 **4 - 5 MINUTE GAMES:** Provides the total number of games the total game time was between **4:00** and **5:00** minutes.
- 63 **5 - 6 MINUTE GAMES:** Provides the total number of games the total game time was between **5:00** and **6:00** minutes.
- 64 **6 - 8 MINUTE GAMES:** Provides the total number of games the total game time was between **6:00** and **8:00** minutes.
- 65 **8 - 10 MINUTE GAMES:** Provides the total number of games the total game time was between **8:00** and **10:00** minutes.
- 66 **10 - 15 MINUTE GAMES:** Provides the total number of games the total game time was between **10:00** and **15:00** minutes.
- 67 **15+ MINUTE GAMES:** Provides the total number of games the total game time was **15:00** and over.

Sec. 3: Go To Audits





Feature Audits (01-165)

To initiate, from the **AUDITS MENU**, select the "SPP" *Icon* with either the **Red "LEFT"** or **Green "RIGHT"** **Buttons** and press the **Black "ENTER"** **Button**. Select and *activate* either of the ">>" *Mini-Icons* to view the next or previous Audit in this group. The display will describe the **Audit Number**, **Audit Name** and the **Current Audit Total** (Value). The current Audit will remain in the display until the next Audit is viewed or when this Menu is exited. **Audits Definition: Programming Use Only.** *The proprietary information provides the total number of times a feature was started, awarded, lit, played and/or completed (awarded); also, the total number of Switch Closures during certain modes or features are tracked (a predetermined single/multiple variations of switch closures are used to determine the lighting and/or completion of the feature stated).*

FEATURE AUDIT TABLE

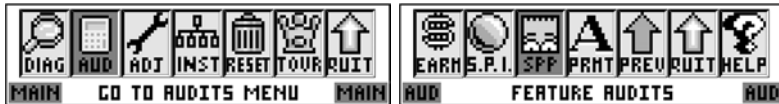

FEATURE AUDITS 01-165 =

*** PROGRAMMING USE ONLY ***

UNLABELED BOXES ARE FOR FUTURE EXPANSION.

01	LEFT ORBITS	56	DD LOOPS START	111	INVASION LIT
02	LEFT RAMP	57	DD LOOPS FINISHED	112	INVASION STARTED
03	KWIK-E-MARTS	58	DD TARGETS START	113	INVASION 2 LOCKS
04	KWIK-E-MART INCREASED	59	DD TARGETS FINISHED	114	INVASION 3 LOCKS
05	BULLY 3-BANK HITS	60	DD MANIA LIT	115	INVASION 4 LOCKS
06	GARAGE DOOR	61	DD MANIA STARTED	116	INVASION 5 LOCKS
07	GARAGE RAMP	62	DD MANIA FINISHED	117	COUCH LOCK LIT
08	GARAGE SECRET PASSAGE	63	I&S ARRIVE LIGHT MBALL	118	COUCH LOCK
09	OTTO SHOTS	64	I&S 1 START	119	COUCH MULTIBALL
10	RIGHT RAMPS	65	I&S 1 JACKPOT INC	120	COUCH 2+ MULTIBALLS
11	CAPTIVE BALL	66	I&S 2 START	121	COUCH JACKPOT
12	RIGHT ORBIT	67	I&S 2 JACKPOT INC	122	COUCH SUPER JACKPOT
13	SPINNER SPINS	68	I&S 3 START	123	COUCH JP VALUE HELD
14	POP BUMPER HITS	69	I&S 3 JACKPOT INC	124	COUCH SECRET BONUS
15	DROP TARGET HITS	70	I&S 4 START	125	COUCH FINISHED
16	DROP BANKS COMPETE	71	I&S 4 JACKPOT INC	126	THOH LIT
17	I&S SAUCER ARRIVALS	72	I&S MB JACKPOT	127	THOH 10X NUCLEAR PLANT
18	TV ARRIVALS	73	I&S MB SUPER JACKPOT	128	THOH DISASTER STARTED
19	COUCH ARRIVALS	74	REVENGE LIT	129	THOH DISASTER POP HITS
20	MONORAIL EXITS	75	REVENGE STARTED	130	THOH DISASTER WON
21	LEFT OUTLANE	76	REVENGE JACKPOTS	131	THOH DISASTER BONUS HITS
22	LEFT INLANE	77	REVENGE SUPER JACKPOTS	132	THOH GIVEAWAY STARTED
23	RIGHT INLANE	78	REVENGE FINISHED	133	THOH GIVEAWAY SHOTS
24	RIGHT OUTLANE	79	OTTO LIT	134	THOH NIGHTMARE STARTED
25	SKILL SHOT STARTS	80	OTTO STARTED	135	THOH NIGHTMARE SPINS
26	CBG SKILL SHOT	81	SMS LIT	136	THOH NIGHTMARE BIG SPINS
27	KWIK-E-MART SKILL SHOT	82	SMS STARTED	137	THOH MAX EVERYTHING
28	BULLY SKILL SHOT	83	SMS JACKPOTS	138	THOH BOUNTY STARTED
29	POPS ADVANCE	84	SMS SUPER JACKPOTS	139	THOH BOUNTY LEFT RAMPS
30	POPS MAXED AWARDS	85	SMS FINISHED	140	THOH BOUNTY MIDDLE RAMPS
31	NUCLEAR VALUE LIT	86	CHALKBOARD COMPLETED	141	THOH BOUNTY RIGHT RAMPS
32	1X NUCLEAR VALUE	87	BONUS X AWARDS	142	THOH CRAZY EB STARTED
33	3X NUCLEAR VALUE	88	BONUS X COMBO AWARDS	143	THOH CRAZY EB GOT E.B.
34	5X NUCLEAR VALUE	89	BONUS X MAXED AWARDS	144	THOH CRAZY EB GOT POINTS
35	TIMER STARTS	90	SPINNER BONUS	145	THOH BIG POINTS
36	TIMER RESTARTS	91	MYSTERY LIT	146	3-WAY COMBOS
37	TIMER SECRET BONUS	92	MYSTERY AWARDS	147	4-WAY COMBOS
38	MORE TIME SMALL	93	MYSTERY EBS	148	5-WAY COMBOS
39	MORE TIME MEDIUM	94	MYSTERY SPECIALS	149	PRETZEL MB START
40	MORE TIME LARGE	95	TV LIT	150	PRETZELS
41	HUS STARTED	96	DUFFMAN STARTED	151	PRETZEL JACKPOT
42	HUS COLLECTED	97	DUFFMAN WON	152	PRETZEL SJ LIT
43	CBG EXTRA BALL AWARD	98	HOMER STARTED	153	PRETZEL SJ
44	CBG SPECIAL AWARD	99	HOMER WON	154	SDMEWM 2 TASK
45	CBG STASH LIT	100	WILLIE STARTED	155	SDMEWM 4 TASK
46	CBG STASH STARTED	101	WILLIE WON	156	SDMEWM LIT
47	CBG STASH COLLECTS	102	WIGGUM STARTED	157	SDMEWM STARTED
48	CBG STASH SECRET BONUS	103	WIGGUM WON	158	SDMEWM JACKPOT
49	CBG STASH FINISHED	104	BART STARTED	159	SDMEWM 2X COMP
50	BULLY 3-BANK COMPLETED	105	BART WON	160	SDMEWM BALLS ADDED
51	DD MODE LIT	106	KRUSTY STARTED	161	SDMEWM I&S SJP LIT
52	DD RAMPS START	107	KRUSTY WON	162	SDMEWM BULLY SJP LIT
53	DD RAMPS FINISHED	108	MONORAIL STARTED	163	SDMEWM SUPER JACKPOT
54	DD BUMPERS START	109	MONORAIL WON	164	NUCLEAR VALUE EB LIT
55	DD BUMPERS FINISHED	110	VICTORY LAPS	165	COUCH MB EB LIT

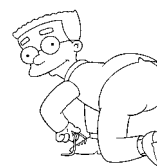



Go To Printer Menu (OPTIONAL USE ONLY)

Operational Usage Note: The use of the following Sub-Menus are **OPTIONAL** and provided as a convenience only. **No special equipment was included with your Pinball Game.** To initiate, from the **AUDITS MENU**, select the "PRNT" Icon with either the **Red "LEFT"** or **Green "RIGHT"** Button and press the **Black "ENTER"** Button. The **PRINTER MENU** appears. A **Tournament Serial Interface (TSI) Board** and a **RS-232 Communication Device** (which can download serial information) are required for proper operation of these Sub-Menus. *Entering the menus & selecting/activating the Icons without the equipment mentioned, will not affect the Pinball Game nor the operation of the Portals™ Service Menu System in any way.* An optional Printer Kit is available for purchase (contact your local distributor).



Quick Printout

To initiate, from the **PRINTER MENU**, select the "QUIK" Icon with either the **Red** or **Green Button** and press the **Black Button**. Select either the "-" or "+" Mini-Icon and press the **Black Button** to start the printout. Per the display instruction, the **Start Button** can also be pressed to start the printout. Only the **Earnings Audits** can be retrieved and/or printed for further processing.



Full Printout

To initiate, from the **PRINTER MENU**, select the "ALISON" Icon with either the **Red** or **Green Button** and press the **Black Button**. Select either the "-" or "+" Mini-Icon and press the **Black Button** to start the download. Per the display instruction, the **Start Button** can also be pressed to start the download. All **Earnings, Standard & Feature Audits** can be retrieved and/or printed for further processing.



Reset Printer

To initiate, from the **PRINTER MENU**, select the "RESET" Icon with either the **Red** or **Green Button** and press the **Black Button**. Select either the "-" or "+" Mini-Icon and press the **Black Button** to clear the "N° of copies printed" count total appearing in the display. **Operational Usage Note:** *Activating the "QUIK" Icon (in the previous Quick Printout) without the special equipment and unique software, will still provide a "count total" in this Reset Printer Menu, which does not affect the operation of the Portals™ Service Menu System in any way.* Activating this "RESET" Icon will reset the "count total" in the display to **00**.

Sec. 3: Go To Audits



AUDIT ABBREVIATIONS USED IN THIS CHAPTER:

CBG: Comic Book Guy	COMP: Completed	DD: Daredevil	EB: / EBs: Extra Ball / s	HUS: Hurry-Ups	I&S: Itchy & Scratchy
INC: Increment	JP: Jackpot	MAX: Maximum	M: Million	MB or MBALL: Multiball	NV: / NVs: Nuclear Values / s
SMS: Springfield Mystery Spot	SDMEWM: Super Duper Mega Extreme Wizard Mode	SJP: Super Jackpot	THOH: Tree House of Horrors	X: Multiplier (Bonus)	



For how to **RESET Audits**, see **Section 3, Chapter 6, GO TO RESET MENU.**



STARTING METER Reading :

STARTING METER Date (MM/DD/YR) :

AUDITOR'S NAME :

CURRENT VOLUME SETTING:

CURRENT METER Reading :

AUDIT Date (MM/DD/YR) :

CPU Version :

DISPLAY Version :

GAME LOCATION NAME :

EARNINGS & STANDARD AUDIT TABLES

MAIN GO TO AUDITS MENU MAIN **AUD** EARNINGS AUDITS **AUD**



EARNINGS AUDITS 01-14 =

01	TOTAL PAID CREDITS	06	COINS THRU RIGHT SLOT	11	TOTAL COINS
02	FREE GAME PERCENTAGE	07	COINS THRU CENTER SLOT	12	TOTAL EARNINGS
03	AVERAGE BALL TIME	08	COINS THRU 4TH SLOT	13	METER CLICKS
04	AVERAGE GAME TIME	09	COINS THRU 5TH SLOT	14	SOFTWARE METER
05	COINS THRU LEFT SLOT	10	COINS THRU 6TH SLOT		

MAIN GO TO AUDITS MENU MAIN **AUD** STANDARD AUDITS **AUD**



STANDARD AUDITS 01-67 =

01	TOTAL BALLS PLAYED	25	12.5M - 15M SCORES	49	PROPRIETARY
02	TOTAL EXTRA BALLS	26	15M - 20M SCORES	50	BASE REPLAY
03	EXTRA BALL PERCENT	27	20M - 30M SCORES	51	LEFT FLIPPER USED
04	REPLAY 1 AWARDS	28	30M - 50M SCORES	52	RIGHT FLIPPER USED
05	REPLAY 2+ AWARDS	29	50M - 75M SCORES	53	PROPRIETARY
06	TOTAL REPLAYS	30	75M - 100M SCORES	54	PROPRIETARY
07	REPLAY PERCENT	31	100M+ SCORES	55	0 - 1 MINUTE GAMES
08	TOTAL SPECIALS	32	AVERAGE SCORES	56	1 - 1.5 MINUTE GAMES
09	SPECIAL PERCENT	33	SERVICE CREDITS	57	1.5 - 2 MINUTE GAMES
10	TOTAL MATCHES	34	BALL SEARCH STARTED	58	2 - 2.5 MINUTE GAMES
11	HIGH SCORE AWARDS	35	LOST BALL FEEDS	59	2.5 - 3 MINUTE GAMES
12	HIGH SCORE PERCENT	36	LOST BALL GAME STARTS	60	3 - 3.5 MINUTE GAMES
13	TOTAL FREE PLAYS	37	LEFT DRAINS	61	3.5 - 4 MINUTE GAMES
14	TOTAL PLAYS	38	CENTER DRAINS	62	4 - 5 MINUTE GAMES
15	0 - 2M SCORES	39	RIGHT DRAINS	63	5 - 6 MINUTE GAMES
16	2M - 3M SCORES	40	TILTS	64	6 - 8 MINUTE GAMES
17	3M - 4M SCORES	41	TOTAL BALLS SAVED	65	8 - 10 MINUTE GAMES
18	4M - 5M SCORES	42	PROPRIETARY	66	10 - 15 MINUTE GAMES
19	5M - 6M SCORES	43	PROPRIETARY	67	15+ MINUTE GAMES
20	6M - 7M SCORES	44	PROPRIETARY		
21	7M - 8M SCORES	45	PROPRIETARY		
22	8M - 9M SCORES	46	PROPRIETARY		
23	9M - 10M SCORES	47	PROPRIETARY		
24	10M - 12.5M SCORES	48	PROPRIETARY		



Comments:

FEATURE AUDIT TABLE

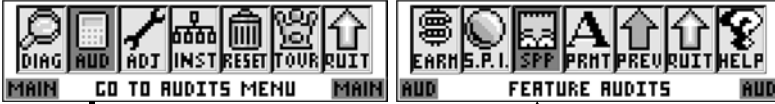

FEATURE AUDITS

01-165 =

*** PROGRAMMING USE ONLY ***

UNLABELED BOXES ARE FOR FUTURE EXPANSION.

01	LEFT ORBITS	56	DD LOOPS START	111	INVASION LIT
02	LEFT RAMP	57	DD LOOPS FINISHED	112	INVASION STARTED
03	KWIK-E-MARTS	58	DD TARGETS START	113	INVASION 2 LOCKS
04	KWIK-E-MART INCREASED	59	DD TARGETS FINISHED	114	INVASION 3 LOCKS
05	BULLY 3-BANK HITS	60	DD MANIA LIT	115	INVASION 4 LOCKS
06	GARAGE DOOR	61	DD MANIA STARTED	116	INVASION 5 LOCKS
07	GARAGE RAMP	62	DD MANIA FINISHED	117	COUCH LOCK LIT
08	GARAGE SECRET PASSAGE	63	I&S ARRIVE LIGHT MBALL	118	COUCH LOCK
09	OTTO SHOTS	64	I&S 1 START	119	COUCH MULTIBALL
10	RIGHT RAMPS	65	I&S 1 JACKPOT INC	120	COUCH 2+ MULTIBALLS
11	CAPTIVE BALL	66	I&S 2 START	121	COUCH JACKPOT
12	RIGHT ORBIT	67	I&S 2 JACKPOT INC	122	COUCH SUPER JACKPOT
13	SPINNER SPINS	68	I&S 3 START	123	COUCH JP VALUE HELD
14	POP BUMPER HITS	69	I&S 3 JACKPOT INC	124	COUCH SECRET BONUS
15	DROP TARGET HITS	70	I&S 4 START	125	COUCH FINISHED
16	DROP BANKS COMPETE	71	I&S 4 JACKPOT INC	126	THOH LIT
17	I&S SAUCER ARRIVALS	72	I&S MB JACKPOT	127	THOH 10X NUCLEAR PLANT
18	TV ARRIVALS	73	I&S MB SUPER JACKPOT	128	THOH DISASTER STARTED
19	COUCH ARRIVALS	74	REVENGE LIT	129	THOH DISASTER POP HITS
20	MONORAIL EXITS	75	REVENGE STARTED	130	THOH DISASTER WON
21	LEFT OUTLANE	76	REVENGE JACKPOTS	131	THOH DISASTER BONUS HITS
22	LEFT INLANE	77	REVENGE SUPER JACKPOTS	132	THOH GIVEAWAY STARTED
23	RIGHT INLANE	78	REVENGE FINISHED	133	THOH GIVEAWAY SHOTS
24	RIGHT OUTLANE	79	OTTO LIT	134	THOH NIGHTMARE STARTED
25	SKILL SHOT STARTS	80	OTTO STARTED	135	THOH NIGHTMARE SPINS
26	CBG SKILL SHOT	81	SMS LIT	136	THOH NIGHTMARE BIG SPINS
27	KWIK-E-MART SKILL SHOT	82	SMS STARTED	137	THOH MAX EVERYTHING
28	BULLY SKILL SHOT	83	SMS JACKPOTS	138	THOH BOUNTY STARTED
29	POPS ADVANCE	84	SMS SUPER JACKPOTS	139	THOH BOUNTY LEFT RAMPS
30	POPS MAXED AWARDS	85	SMS FINISHED	140	THOH BOUNTY MIDDLE RAMPS
31	NUCLEAR VALUE LIT	86	CHALKBOARD COMPLETED	141	THOH BOUNTY RIGHT RAMPS
32	1X NUCLEAR VALUE	87	BONUS X AWARDS	142	THOH CRAZY EB STARTED
33	3X NUCLEAR VALUE	88	BONUS X COMBO AWARDS	143	THOH CRAZY EB GOT E.B.
34	5X NUCLEAR VALUE	89	BONUS X MAXED AWARDS	144	THOH CRAZY EB GOT POINTS
35	TIMER STARTS	90	SPINNER BONUS	145	THOH BIG POINTS
36	TIMER RESTARTS	91	MYSTERY LIT	146	3-WAY COMBOS
37	TIMER SECRET BONUS	92	MYSTERY AWARDS	147	4-WAY COMBOS
38	MORE TIME SMALL	93	MYSTERY EBS	148	5-WAY COMBOS
39	MORE TIME MEDIUM	94	MYSTERY SPECIALS	149	PRETZEL MB START
40	MORE TIME LARGE	95	TV LIT	150	PRETZELS
41	HUS STARTED	96	DUFFMAN STARTED	151	PRETZEL JACKPOT
42	HUS COLLECTED	97	DUFFMAN WON	152	PRETZEL SJ LIT
43	CBG EXTRA BALL AWARD	98	HOMER STARTED	153	PRETZEL SJ
44	CBG SPECIAL AWARD	99	HOMER WON	154	SDMEWM 2 TASK
45	CBG STASH LIT	100	WILLIE STARTED	155	SDMEWM 4 TASK
46	CBG STASH STARTED	101	WILLIE WON	156	SDMEWM LIT
47	CBG STASH COLLECTS	102	WIGGUM STARTED	157	SDMEWM STARTED
48	CBG STASH SECRET BONUS	103	WIGGUM WON	158	SDMEWM JACKPOT
49	CBG STASH FINISHED	104	BART STARTED	159	SDMEWM 2X COMP
50	BULLY 3-BANK COMPLETED	105	BART WON	160	SDMEWM BALLS ADDED
51	DD MODE LIT	106	KRUSTY STARTED	161	SDMEWM I&S SJP LIT
52	DD RAMPS START	107	KRUSTY WON	162	SDMEWM BULLY SJP LIT
53	DD RAMPS FINISHED	108	MONORAIL STARTED	163	SDMEWM SUPER JACKPOT
54	DD BUMPERS START	109	MONORAIL WON	164	NUCLEAR VALUE EB LIT
55	DD BUMPERS FINISHED	110	VICTORY LAPS	165	COUCH MB EB LIT

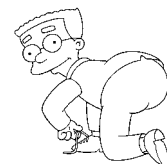

MULTI-WEEK TOURNAMENT AUDIT TABLES

STARTING METER Reading :	STARTING METER Date (MM/DD/YR) :	AUDITOR'S NAME :	CURRENT VOLUME SETTING:																				
<input type="text"/>	<input type="text"/>		<input type="text"/>																				
CURRENT METER Reading :	AUDIT Date (MM/DD/YR) :	CPU Version :	DISPLAY Version :																				
<input type="text"/>	<input type="text"/>	<input type="text"/>	<input type="text"/>																				
<table border="1" style="width: 100%; border-collapse: collapse;"> <tr><td style="width: 25%; text-align: center;">01</td><td>TOTAL PLAYS</td></tr> <tr><td style="text-align: center;">02</td><td>TOURNAMENT PLAYS</td></tr> <tr><td style="text-align: center;">03</td><td>TOTAL GAME EARNINGS</td></tr> <tr><td style="text-align: center;">04</td><td>TOTAL TOUR. EARNINGS</td></tr> <tr><td style="text-align: center;">05</td><td>JACKPOT</td></tr> </table>		01	TOTAL PLAYS	02	TOURNAMENT PLAYS	03	TOTAL GAME EARNINGS	04	TOTAL TOUR. EARNINGS	05	JACKPOT	<table border="1" style="width: 100%; border-collapse: collapse;"> <tr><td style="width: 25%; text-align: center;">06</td><td>NET EARNINGS</td></tr> <tr><td style="text-align: center;">07</td><td>ACCUM. TOTAL PLAYS</td></tr> <tr><td style="text-align: center;">08</td><td>ACCUM. TOUR. PLAYS</td></tr> <tr><td style="text-align: center;">09</td><td>ACCUM. EARNINGS</td></tr> <tr><td style="text-align: center;">10</td><td>ACCUM. TOUR EARNINGS</td></tr> </table>		06	NET EARNINGS	07	ACCUM. TOTAL PLAYS	08	ACCUM. TOUR. PLAYS	09	ACCUM. EARNINGS	10	ACCUM. TOUR EARNINGS
01	TOTAL PLAYS																						
02	TOURNAMENT PLAYS																						
03	TOTAL GAME EARNINGS																						
04	TOTAL TOUR. EARNINGS																						
05	JACKPOT																						
06	NET EARNINGS																						
07	ACCUM. TOTAL PLAYS																						
08	ACCUM. TOUR. PLAYS																						
09	ACCUM. EARNINGS																						
10	ACCUM. TOUR EARNINGS																						
		<table border="1" style="width: 100%; border-collapse: collapse;"> <tr><td style="width: 25%; text-align: center;">11</td><td>ACCUM. JACKPOT</td></tr> <tr><td style="text-align: center;">12</td><td># TOURNAMENTS</td></tr> <tr><td colspan="2"> </td></tr> <tr><td colspan="2"> </td></tr> <tr><td colspan="2"> </td></tr> </table>		11	ACCUM. JACKPOT	12	# TOURNAMENTS																
11	ACCUM. JACKPOT																						
12	# TOURNAMENTS																						

STARTING METER Reading :	STARTING METER Date (MM/DD/YR) :	AUDITOR'S NAME :	CURRENT VOLUME SETTING:																				
<input type="text"/>	<input type="text"/>		<input type="text"/>																				
CURRENT METER Reading :	AUDIT Date (MM/DD/YR) :	CPU Version :	DISPLAY Version :																				
<input type="text"/>	<input type="text"/>	<input type="text"/>	<input type="text"/>																				
<table border="1" style="width: 100%; border-collapse: collapse;"> <tr><td style="width: 25%; text-align: center;">01</td><td>TOTAL PLAYS</td></tr> <tr><td style="text-align: center;">02</td><td>TOURNAMENT PLAYS</td></tr> <tr><td style="text-align: center;">03</td><td>TOTAL GAME EARNINGS</td></tr> <tr><td style="text-align: center;">04</td><td>TOTAL TOUR. EARNINGS</td></tr> <tr><td style="text-align: center;">05</td><td>JACKPOT</td></tr> </table>		01	TOTAL PLAYS	02	TOURNAMENT PLAYS	03	TOTAL GAME EARNINGS	04	TOTAL TOUR. EARNINGS	05	JACKPOT	<table border="1" style="width: 100%; border-collapse: collapse;"> <tr><td style="width: 25%; text-align: center;">06</td><td>NET EARNINGS</td></tr> <tr><td style="text-align: center;">07</td><td>ACCUM. TOTAL PLAYS</td></tr> <tr><td style="text-align: center;">08</td><td>ACCUM. TOUR. PLAYS</td></tr> <tr><td style="text-align: center;">09</td><td>ACCUM. EARNINGS</td></tr> <tr><td style="text-align: center;">10</td><td>ACCUM. TOUR EARNINGS</td></tr> </table>		06	NET EARNINGS	07	ACCUM. TOTAL PLAYS	08	ACCUM. TOUR. PLAYS	09	ACCUM. EARNINGS	10	ACCUM. TOUR EARNINGS
01	TOTAL PLAYS																						
02	TOURNAMENT PLAYS																						
03	TOTAL GAME EARNINGS																						
04	TOTAL TOUR. EARNINGS																						
05	JACKPOT																						
06	NET EARNINGS																						
07	ACCUM. TOTAL PLAYS																						
08	ACCUM. TOUR. PLAYS																						
09	ACCUM. EARNINGS																						
10	ACCUM. TOUR EARNINGS																						
		<table border="1" style="width: 100%; border-collapse: collapse;"> <tr><td style="width: 25%; text-align: center;">11</td><td>ACCUM. JACKPOT</td></tr> <tr><td style="text-align: center;">12</td><td># TOURNAMENTS</td></tr> <tr><td colspan="2"> </td></tr> <tr><td colspan="2"> </td></tr> <tr><td colspan="2"> </td></tr> </table>		11	ACCUM. JACKPOT	12	# TOURNAMENTS																
11	ACCUM. JACKPOT																						
12	# TOURNAMENTS																						

STARTING METER Reading :	STARTING METER Date (MM/DD/YR) :	AUDITOR'S NAME :	CURRENT VOLUME SETTING:																				
<input type="text"/>	<input type="text"/>		<input type="text"/>																				
CURRENT METER Reading :	AUDIT Date (MM/DD/YR) :	CPU Version :	DISPLAY Version :																				
<input type="text"/>	<input type="text"/>	<input type="text"/>	<input type="text"/>																				
<table border="1" style="width: 100%; border-collapse: collapse;"> <tr><td style="width: 25%; text-align: center;">01</td><td>TOTAL PLAYS</td></tr> <tr><td style="text-align: center;">02</td><td>TOURNAMENT PLAYS</td></tr> <tr><td style="text-align: center;">03</td><td>TOTAL GAME EARNINGS</td></tr> <tr><td style="text-align: center;">04</td><td>TOTAL TOUR. EARNINGS</td></tr> <tr><td style="text-align: center;">05</td><td>JACKPOT</td></tr> </table>		01	TOTAL PLAYS	02	TOURNAMENT PLAYS	03	TOTAL GAME EARNINGS	04	TOTAL TOUR. EARNINGS	05	JACKPOT	<table border="1" style="width: 100%; border-collapse: collapse;"> <tr><td style="width: 25%; text-align: center;">06</td><td>NET EARNINGS</td></tr> <tr><td style="text-align: center;">07</td><td>ACCUM. TOTAL PLAYS</td></tr> <tr><td style="text-align: center;">08</td><td>ACCUM. TOUR. PLAYS</td></tr> <tr><td style="text-align: center;">09</td><td>ACCUM. EARNINGS</td></tr> <tr><td style="text-align: center;">10</td><td>ACCUM. TOUR EARNINGS</td></tr> </table>		06	NET EARNINGS	07	ACCUM. TOTAL PLAYS	08	ACCUM. TOUR. PLAYS	09	ACCUM. EARNINGS	10	ACCUM. TOUR EARNINGS
01	TOTAL PLAYS																						
02	TOURNAMENT PLAYS																						
03	TOTAL GAME EARNINGS																						
04	TOTAL TOUR. EARNINGS																						
05	JACKPOT																						
06	NET EARNINGS																						
07	ACCUM. TOTAL PLAYS																						
08	ACCUM. TOUR. PLAYS																						
09	ACCUM. EARNINGS																						
10	ACCUM. TOUR EARNINGS																						
		<table border="1" style="width: 100%; border-collapse: collapse;"> <tr><td style="width: 25%; text-align: center;">11</td><td>ACCUM. JACKPOT</td></tr> <tr><td style="text-align: center;">12</td><td># TOURNAMENTS</td></tr> <tr><td colspan="2"> </td></tr> <tr><td colspan="2"> </td></tr> <tr><td colspan="2"> </td></tr> </table>		11	ACCUM. JACKPOT	12	# TOURNAMENTS																
11	ACCUM. JACKPOT																						
12	# TOURNAMENTS																						

STARTING METER Reading :	STARTING METER Date (MM/DD/YR) :	AUDITOR'S NAME :	CURRENT VOLUME SETTING:																				
<input type="text"/>	<input type="text"/>		<input type="text"/>																				
CURRENT METER Reading :	AUDIT Date (MM/DD/YR) :	CPU Version :	DISPLAY Version :																				
<input type="text"/>	<input type="text"/>	<input type="text"/>	<input type="text"/>																				
<table border="1" style="width: 100%; border-collapse: collapse;"> <tr><td style="width: 25%; text-align: center;">01</td><td>TOTAL PLAYS</td></tr> <tr><td style="text-align: center;">02</td><td>TOURNAMENT PLAYS</td></tr> <tr><td style="text-align: center;">03</td><td>TOTAL GAME EARNINGS</td></tr> <tr><td style="text-align: center;">04</td><td>TOTAL TOUR. EARNINGS</td></tr> <tr><td style="text-align: center;">05</td><td>JACKPOT</td></tr> </table>		01	TOTAL PLAYS	02	TOURNAMENT PLAYS	03	TOTAL GAME EARNINGS	04	TOTAL TOUR. EARNINGS	05	JACKPOT	<table border="1" style="width: 100%; border-collapse: collapse;"> <tr><td style="width: 25%; text-align: center;">06</td><td>NET EARNINGS</td></tr> <tr><td style="text-align: center;">07</td><td>ACCUM. TOTAL PLAYS</td></tr> <tr><td style="text-align: center;">08</td><td>ACCUM. TOUR. PLAYS</td></tr> <tr><td style="text-align: center;">09</td><td>ACCUM. EARNINGS</td></tr> <tr><td style="text-align: center;">10</td><td>ACCUM. TOUR EARNINGS</td></tr> </table>		06	NET EARNINGS	07	ACCUM. TOTAL PLAYS	08	ACCUM. TOUR. PLAYS	09	ACCUM. EARNINGS	10	ACCUM. TOUR EARNINGS
01	TOTAL PLAYS																						
02	TOURNAMENT PLAYS																						
03	TOTAL GAME EARNINGS																						
04	TOTAL TOUR. EARNINGS																						
05	JACKPOT																						
06	NET EARNINGS																						
07	ACCUM. TOTAL PLAYS																						
08	ACCUM. TOUR. PLAYS																						
09	ACCUM. EARNINGS																						
10	ACCUM. TOUR EARNINGS																						
		<table border="1" style="width: 100%; border-collapse: collapse;"> <tr><td style="width: 25%; text-align: center;">11</td><td>ACCUM. JACKPOT</td></tr> <tr><td style="text-align: center;">12</td><td># TOURNAMENTS</td></tr> <tr><td colspan="2"> </td></tr> <tr><td colspan="2"> </td></tr> <tr><td colspan="2"> </td></tr> </table>		11	ACCUM. JACKPOT	12	# TOURNAMENTS																
11	ACCUM. JACKPOT																						
12	# TOURNAMENTS																						

MULTI-WEEK TOURNAMENT AUDIT TABLES

STARTING METER Reading :	STARTING METER Date (MM/DD/YR) :	AUDITOR'S NAME :	CURRENT VOLUME SETTING:
<input type="text"/>	<input type="text"/>		<input type="text"/>
CURRENT METER Reading :	AUDIT Date (MM/DD/YR) :	CPU Version :	DISPLAY Version :
<input type="text"/>	<input type="text"/>	<input type="text"/>	<input type="text"/>
			GAME LOCATION NAME :
			<input type="text"/>

01	TOTAL PLAYS	06	NET EARNINGS	11	ACCUM. JACKPOT
02	TOURNAMENT PLAYS	07	ACCUM. TOTAL PLAYS	12	# TOURNAMENTS
03	TOTAL GAME EARNINGS	08	ACCUM. TOUR. PLAYS		
04	TOTAL TOUR. EARNINGS	09	ACCUM. EARNINGS		
05	JACKPOT	10	ACCUM. TOUR EARNINGS		

STARTING METER Reading :	STARTING METER Date (MM/DD/YR) :	AUDITOR'S NAME :	CURRENT VOLUME SETTING:
<input type="text"/>	<input type="text"/>		<input type="text"/>
CURRENT METER Reading :	AUDIT Date (MM/DD/YR) :	CPU Version :	DISPLAY Version :
<input type="text"/>	<input type="text"/>	<input type="text"/>	<input type="text"/>
			GAME LOCATION NAME :
			<input type="text"/>

01	TOTAL PLAYS	06	NET EARNINGS	11	ACCUM. JACKPOT
02	TOURNAMENT PLAYS	07	ACCUM. TOTAL PLAYS	12	# TOURNAMENTS
03	TOTAL GAME EARNINGS	08	ACCUM. TOUR. PLAYS		
04	TOTAL TOUR. EARNINGS	09	ACCUM. EARNINGS		
05	JACKPOT	10	ACCUM. TOUR EARNINGS		

STARTING METER Reading :	STARTING METER Date (MM/DD/YR) :	AUDITOR'S NAME :	CURRENT VOLUME SETTING:
<input type="text"/>	<input type="text"/>		<input type="text"/>
CURRENT METER Reading :	AUDIT Date (MM/DD/YR) :	CPU Version :	DISPLAY Version :
<input type="text"/>	<input type="text"/>	<input type="text"/>	<input type="text"/>
			GAME LOCATION NAME :
			<input type="text"/>

01	TOTAL PLAYS	06	NET EARNINGS	11	ACCUM. JACKPOT
02	TOURNAMENT PLAYS	07	ACCUM. TOTAL PLAYS	12	# TOURNAMENTS
03	TOTAL GAME EARNINGS	08	ACCUM. TOUR. PLAYS		
04	TOTAL TOUR. EARNINGS	09	ACCUM. EARNINGS		
05	JACKPOT	10	ACCUM. TOUR EARNINGS		

STARTING METER Reading :	STARTING METER Date (MM/DD/YR) :	AUDITOR'S NAME :	CURRENT VOLUME SETTING:
<input type="text"/>	<input type="text"/>		<input type="text"/>
CURRENT METER Reading :	AUDIT Date (MM/DD/YR) :	CPU Version :	DISPLAY Version :
<input type="text"/>	<input type="text"/>	<input type="text"/>	<input type="text"/>
			GAME LOCATION NAME :
			<input type="text"/>

01	TOTAL PLAYS	06	NET EARNINGS	11	ACCUM. JACKPOT
02	TOURNAMENT PLAYS	07	ACCUM. TOTAL PLAYS	12	# TOURNAMENTS
03	TOTAL GAME EARNINGS	08	ACCUM. TOUR. PLAYS		
04	TOTAL TOUR. EARNINGS	09	ACCUM. EARNINGS		
05	JACKPOT	10	ACCUM. TOUR EARNINGS		



STANDARD & FEATURE ADJUSTMENT TABLES

STANDARD ADJUSTMENTS 01-51

Nr.	ADJUSTMENT NAME	USA DEFAULT	YOUR SETTING
01	REPLAY TYPE	AUTO	
02	REPLAY PERCENTAGE	10%	
03	REPLAY AWARD	CREDIT	
04	REPLAY LEVELS	1: 10,000,000	
05	REPLAY BOOST	YES	
06	SPECIAL AWARD	CREDIT	
07	SPECIAL PERCENTAGE	2%	
08	FREE GAME LIMIT	05	
09	EXTRA BALL LIMIT	09	
10	EXTRA BALL PERCENTAGE	25%	
11	GAME PRICING	USA 5	
12	MATCH AWARD	CREDIT	
13	MATCH PERCENTAGE	9%	
14	BALLS PER GAME	03	
15	TILT WARNINGS	01	
16	CREDIT LIMIT	30	
17	ALLOW HIGH SCORES	YES	
18	GRAND CHAMPION AWARDS	01	
19	HIGH SCORE #1 AWARDS	01	
20	HIGH SCORE #2 AWARDS	00	
21	HIGH SCORE #3 AWARDS	00	
22	HIGH SCORE #4 AWARDS	00	
23	GRAND CHAMPION SCORE	50,000,000	
24	DEFAULT HIGH SCORE #1	40,000,000	
25	DEFAULT HIGH SCORE #2	35,000,000	
26	DEFAULT HIGH SCORE #3	30,000,000	

Nr.	ADJUSTMENT NAME	USA DEFAULT	YOUR SETTING
27	DEFAULT HIGH SCORE #4	25,000,000	
28	HSTD RESET COUNT	2,000	
29	HIGH SCORE INITIALS	3 INITIALS	
30	FREE PLAY	NO	
31	CUSTOM MESSAGE	ON	
32	FLASH LAMP POWER	NORMAL	
33	COIL PULSE POWER	NORMAL	
34	KNOCKER VOLUME	NORMAL	
35	GAME RESTART	YES	
36	BILL VALIDATOR	NO	
37	BKGRND MUSIC VOLUME	01	
38	FREEZE TIME	OFF	
39	UK POST SAVE ENABLED	NO	
40	TIMED PLUNGER	OFF	
41	FLIPPER BALL LAUNCH	DISABLED	
42	COINDOOR BALL SAVER	NO	
43	COMPETITION MODE	NO	
44	CONSOLATION BALL	YES	
45	FAST BOOT	NO	
46	Q24 OPTION	COIN METER	
47	TICKET DISP. INSTALLED	NO	
48	ALLOW PLAYER COMP. MODE	YES	
49	TECH ALERT WARNING	NEVER	
50	LOCATION ID	00	
51	GAME ID	00	

Note: Shaded box around Standard & Feature Adjustment Number, indicates new Adjustments added and / or USA Default changes after Version 3.00. This Table reflects v4.00+ (CPU/Display) as of 08-14-03 printing.

Note: If Game & Display ROMs other than USA are installed, along with the proper Dip Switch Settings, different Defaults will appear. If changes are made (or your Defaults are not USA), enter them with pencil in the YOUR SETTING spaces provided for reference.

Sec. 3: Adjustments



Shortcut to Standard Adjustment 31.

FEATURE ADJUSTMENTS 01-36

Nr.	ADJUSTMENT NAME	USA DEFAULT	YOUR SETTING
01	3 BANK DIFFICULTY	HARD	
02	DAREDEVIL DIFFICULTY	MODERATE	
03	# OF RAMPS FOR 1ST EB	10	
04	# OF RAMPS NEXT EBS	50	
05	MAX EBS FROM RAMP	04	
06	RAMP EB MEMORY	YES	
07	1ST RAMP TREEHOUSE	05	
08	NEXT TREEHOUSE	10	
09	1ST COUCH LOCKS UNLIT	02	
10	COUCH MB DIFFICULTY	EXEASY	
11	TV LIGHTING DIFFICULTY	EASY	
12	MYSTERY LIGHTING DIFF.	MODERATE	
13	MYSTERY EB MEMORY	NO	
14	MYSTERY SPECIAL MEMORY	NO	
15	MAIN TIMER DIFFICULTY	MODERATE	
16	1ST I&S WITH DROPS	02	
17	1ST I&S DROPS RESET	03	
18	1ST I&S SHOT TWICE	01	

Nr.	ADJUSTMENT NAME	USA DEFAULT	YOUR SETTING
19	ENABLE REVERSED FLIPPERS	YES	
20	GARAGE DOOR DIFF	EASY	
21	OTTO LIGHTING DIFF	EASY	
22	SHOW UPPER FLIPPERS	YES	
23	CBG HURRY UP DIFFICULTY	MODERATE	
24	# OF NVS FOR 1ST EB	10	
25	# OF NVS NEXT EBS	50	
26	MAX EBS FROM NUCLEAR	04	
27	NUCLEAR EB MEMORY	YES	
28	COUCH EB DIFFICULTY	EASY	
29	COUCH EB MEMORY	NO	
30	CBG EB MEMORY	NO	
31	CBG SPECIAL MEMORY	NO	
32	SDMEWM SPECIAL MEMORY	NO	
33	MONORAIL INTERVAL	05	
34	ADULT CONTENT ENABLED	YES	
35	HOLD COUCH LOCKS	1-PLAYER GAMES	
36	ALLOW VOLUME EFFECTS	YES	

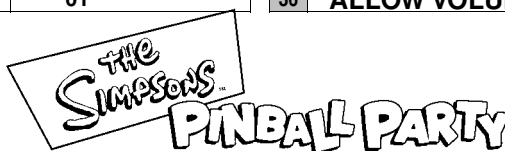

Go To Adjustments Menu

Overview

The Portals™ Service Menu System provides **87** Adjustments to vary Game Functions to customize for your particular needs. The Adjustments are divided into 2 groups: • **Standard Adjustments (01-51)** and • **Feature Adjustments (01-36)**. Game code may get upgraded during production; compare all Adjustments in the display with the manual and make any corrections to the Adjustment Table (*previous page*), as necessary. Adjustments are subject to change (*with or without notice*). To view Adjustments in the display, enter the **Portals™ Service Menu System**. When a change is made and then the next / previous Adjustment is selected (*or the Sub-Menu is exited*), the display will momentarily flash **REQUEST INSTALLED**. For **further customization of Game Play Difficulty or Game Play Type** or how to **RESET ONLY the Adjustments**, see **Section 3, Chapter 5, GO TO INSTALLS MENU**.



Important: The Coin Door must be **OPEN** allowing the **Memory Protect Switch** to be disabled, so any Adjustment changes can be made.



EXPLANATION & USAGE OF COMMON LARGE & MINI-ICONS USED IN VARIOUS MENUS & SUB-MENUS:



These **non-selectable** icons appear in the selected Menu only when there are **MORE** icons to the **LEFT** or to the **RIGHT** available for selection.



Select and activate to return to the **PREVIOUS** Menu.



Select and activate to **QUIT**, exits & returns to the **Attract Mode**.



Select and activate to view **HELP** Screens of the current Menu*.



Select and activate to: Move **LEFT** or **RIGHT**, select previous / next or move backwards / forwards.



DECREMENT (-) or **INCREMENT (+)** displayed value or select previous / next.

* **Help Note:** An explanation of each Mini-Icon at that menu level will cycle continuously. To exit a display where no Mini-Icons are available for selection, pressing any button will exit the display.



GO TO ADJUSTMENTS MENU

After entering **Portals™**, the **MAIN MENU** now appears. Select the "ADJ" icon in the **MAIN MENU** with either the **Red "LEFT"** or **Green "RIGHT"** Buttons (the **Flipper Buttons** operates in the same manner) and press the **Black "ENTER"** Button (the **Start Button** operates in the same manner). The **ADJUSTMENTS MENU** appears. Continue through this chapter for the explanation & usage of the *Icons* in the **ADJUSTMENTS MENU**.



Standard Adjustments (01-51)

To initiate, from the **ADJUSTMENTS MENU**, select the "S.P.I." icon with either the **Red "LEFT"** or **Green "RIGHT"** Buttons and press the **Black "ENTER"** Button. Select and activate either of the ">>" Mini-Icons to view the next or previous Adjustment in this group. Select and activate either of the "-" or "+" Mini-Icons to change the setting, if desired (*the Default Setting is noted in the definitions below*). The display will describe the **Adjustment Number**, **Adjustment Name** and the **Current Adjustment Setting**. The current Adjustment will remain in the display until the next Adjustment is view or when this Menu is exited.

WARNING: Changes made in any Adjustments will be lost after a **FACTORY RESET** or removal of the **CPU/Sound Board Batteries**.

Nr.

STANDARD ADJUSTMENT NAME: Definition

REPLAY TYPE: Set to **AUTO**, **DYNAMIC**, **FIXED** or **NONE**. Default is **AUTO**. Selecting **NONE** will make Standard Adjustments **2-5 NOT AVAILABLE**. Selecting **FIXED** will make Standard Adjustment **2 NOT AVAILABLE**. If selected **AUTO**, **DYNAMIC** or **FIXED**, you will need to then select the number of Replay Levels and Score Threshold (*in Standard Adj. 4*) desired for the player to receive a Replay Award (*select type in Standard Adj. 3*). The Default Score appears as a starting point after the Level amount is selected. **AUTO & DYNAMIC** will then get based on the Replay Percentage (*in Standard Adjustment 2*).

01

• Select **FIXED** to give the player a Replay Award as the Score Threshold is reached. This Score Threshold **will not** adjust up or down. • Select **AUTO** to give the player a Replay Award as the Score Threshold is reached. This Score Threshold **will automatically** adjust up or down based on the Replay Percentage chosen (*in Std. Adj. 2*). The game periodically adjusts based upon the Player Base Skill Level. • Select **DYNAMIC** to give the player a Replay Award as the Score Threshold is reached. This Score Threshold will go down every game based on the Replay Percentage selected. For (*Dynamic*) example, if the Score Threshold is 50,000,00 and the Replay Percentage selected is 10%, every game a player does not reach the Score Threshold, the score to reach will drop by 5,000,000 (10% of 50M). This will continue every game until the Threshold Score is reached. Thus, if the score then drops to 15,000,000 after 7 games and is then achieved, the Replay Award is given. The original Score Threshold is added to 15,000,000 and is now 65,000,000. It will then take the same player 10 games to reach 15,000,000.

02

REPLAY PERCENTAGE: Set between **01% - 50**. Default is **10%**. This Adjustment is required if Standard Adjustment 1 is set to **AUTO** or **DYNAMIC**.

Standard Adjustments 03-11 continued on the next page.





03 REPLAY AWARD: Set to EXTRA BALL, CREDIT, TICKET* or TOKEN*. Default is CREDIT. Select EXTRA BALL if awarding a CREDIT, TICKET/TOKEN is prohibited in your area.

*TICKET or TOKEN is selected, the game will require an optional Ticket or Token Dispenser If selected Token, then Standard Adjustment 46, Q24 Option, must be changed accordingly.

04 REPLAY LEVELS: Set between 1 - 4 for the number of Replay Levels to be active. Default is 1. A "Drop-Down" Table appears showing Replay Level 1. Adjust the Replay Level between 10M - 9.99B (Default Score appears as a starting point) using the "-" or "+" Mini-Icons, then use the ">>" Mini-Icon to go to next Level (if selected more than 1) and select the next highest Threshold Score(s) desired.

REPLAY BOOST: Set to YES or NO. Default is YES. This Adjustment works only when Standard Adjustment 1, Replay Type, is set to FIXED or AUTO.

05 When set to YES, while FIXED or AUTO maintains the Replay Levels, Replay Boost works as follows: If the Replay Level is 7,000,000 (regardless of the Replay Percentage), and the Player scores 20M, and receives the Replay Award, the next game the Current Replay Level is added to this base. Thus the next game, the Replay Level is 14,000,000. The Player agains scores 20M. The next game the Player will need to achieve 21,000,00 to earn the Replay Award. If the Player does not achieve 21,000,000, the next game reverts back to the original 7,000,000 or the new adjusted level maintained by the Fixed or Autopercentageing Feature.

06 SPECIAL AWARD: Set to EXTRA BALL, CREDIT, TICKET*, TOKEN* or POINTS. Default is CREDIT. Select EXTRA BALL or POINTS if awarding a CREDIT or TICKET/TOKEN is prohibited in your area.

07 SPECIAL PERCENTAGE: Set between 1% - 5%. Default is 2%. This adjustment allows the operator to adjust how frequently the Special Feature is made available to the player.

08 FREE GAME LIMIT: Set between 01 - 09, NO FREE GAMES or UNLIMITED. Default is 05. Set the maximum number of Free Games that may be accumulated per game.

09 EXTRA BALL LIMIT: Set between 01 - 09, NO EXTRA BALLS or UNLIMITED. Default is 09. Set the number of Extra Balls that may be accumulated per game.

10 EXTRA BALL PERCENTAGE: Set between 01% - 50%. Default is 25%. This adjustment allows the operator to adjust how frequently the Extra Ball Feature is made available to the player.

11 GAME PRICING: There are two (2) methods available for Coin Switch Programming: Standard & Custom. Set between USA 1 thru EURO 12 or CUSTOM. USA Factory Default Setting is USA 5.

Sec. 3: Adjustments

The Dip Switch Settings (Sw. 300) on the CPU/Sound Board for each Country must match with what is shown in the USA & Int'l. Standard Pricing Select Tables for your country to have correct operation (see the next page). For a Standard Selection (USA or International): Select & activate either the "-" or "+" Mini-Icons to move backward or forward in the Display; With your choice appearing in the display, select & activate the ">>" Mini-Icon to advance and "lock-in" the change (display will momentarily flash REQUEST INSTALLED).

If CUSTOM is selected (appears in display), after selecting & activating any Mini-Icon (except for "-" or "+"), the display will momentarily flash REQUEST INSTALLED with the display "LEFT COIN: 0 PULSE" appearing. Use the "<<" or ">>" Mini-Icons to select the next choice (see Table Examples below) and the "-" or "+" Mini-Icons to customize the PULSES, CREDITS & CLICKS from 0 to 99.

The prescribed number of PULSES required for 1 CREDIT must be set according to the Pricing Scheme desired. Some simple calculations are required to get the proper set-up. After customizing, test the set-up with appropriate Coins or Bills and adjust, if necessary. Note: Clicks can be changed if an optional Coin Meter is installed.

Table with 16 columns: LEFT COIN, CENTER COIN, RIGHT COIN, FOURTH COIN, ONE CREDIT, BONUS 1, BONUS 2, BONUS 1, BONUS 2, LEFT COIN, CENTER COIN, RIGHT COIN, FOURTH COIN. Includes Example 1 and Pricing Scheme Desired.

In Example 1, note the LEFT (and RIGHT) COIN: 3 PULSES and ONE CREDIT: 4 PULSES. Since every Coin inserted produces 3 Pulses & every Credit requires 4 Pulses, 2 Coins (50c) will produce 6 Pulses (4 Pulses for the 1st Credit + 2 Pulses remains in escrow). The 3rd Coin (75c) provides another 3 Pulses for a total of 5 Pulses (4 Pulses for the 2nd Credit + 1 Pulse remains in escrow). The 4th Coin (\$1.00) provides another 3 Pulses for a total of 4 Pulses (4 Pulses for the 3rd Credit + 0 Pulses remain). The CENTER COIN: 12 PULSES is set this way (with a Bill Validator attached); every \$1-Bill inserted produces 12 Pulses or 3 Credits.

Table with 16 columns: LEFT COIN, CENTER COIN, RIGHT COIN, FOURTH COIN, ONE CREDIT, BONUS 1, BONUS 2, BONUS 1, BONUS 2, LEFT COIN, CENTER COIN, RIGHT COIN, FOURTH COIN. Includes Example 2 and Pricing Scheme Desired.

In Example 2, similar to Example 1, however, BONUS CREDITS are implemented. In addition to receiving 3 plays for every \$1.00, the player is awarded an extra Credit for every 2nd dollar inserted before game start.

Table with 16 columns: LEFT COIN, CENTER COIN, RIGHT COIN, FOURTH COIN, ONE CREDIT, BONUS 1, BONUS 2, BONUS 1, BONUS 2, LEFT COIN, CENTER COIN, RIGHT COIN, FOURTH COIN. Includes Example 3 and Pricing Scheme Desired.

In Example 3, a Pricing Scheme for a cheaper game is shown. An extra Pulse is put in escrow for every 25c, thus at 4X 25c inserted, another Credit is given, and the BONUS 1: 20 PULSES threshold is also met, so 6/ \$1.00 is achieved. BONUS 2: 40 PULSES is set, so when this threshold is met with \$2.00, 13 Credits are produced.

Table with 16 columns: LEFT COIN, CENTER COIN, RIGHT COIN, FOURTH COIN, ONE CREDIT, BONUS 1, BONUS 2, BONUS 1, BONUS 2, LEFT COIN, CENTER COIN, RIGHT COIN, FOURTH COIN. Includes Example 4 and Pricing Scheme Desired.

In Example 4, a Pricing Scheme using a different currency (i.e. British Sterling) is shown to provide another way coins (or tokens) can be utilized to custom tailor to your own needs.

Standard Adjustment 11, Custom Pricing, continued on the next page.





USA & International Standard Pricing Select Tables

Main table with columns: CPU/SOUND BOARD DIP SWITCH 300 SETTING, COUNTRY SETTING OPTION(S), COIN MECHANISMS (SWITCHES) COINS THRU ... SLOT: LEFT CENTER RIGHT 4TH, PRICING SCHEME, Requires SPI Coin Card(s) Part Number. Includes settings for USA, Austria, Australia, Belgium, Canada, Denmark, Finland, France, Germany, Greece, Italy, Netherlands, New Zealand, Norway, Portugal, Spain, Sweden, Switzerland, and UK.

Sec. 3: Adjustments

Note: The Country Setting Option above noted with "«" & "»" denotes the Factory Default Setting (subject to change).

Standard Adj. 11, Custom Pricing, and Std. Adj. 12-32 continued on the next page.

Go To Adjustments Menu





Euro Summary Pricing Select Table

Pos.	1	2	3	4	5	6	7	8	Alternate Settings	LEFT	CENTER	RIGHT	4TH			
ON	S	E	E	A	B	O	V	E	Euro 1					1 / €50		755-5401-01
OFF	S	E	T	T	I	N	G	S	Euro 2					1 / €50	5 / €2.00	755-5401-02
									Euro 3					1 / €50	3 / €1.00	755-5401-03
									Euro 4					1 / €50	6 / €2.00	755-5401-04
									Euro 5					1 / €50	3 / €1.00	755-5401-05
									Euro 6	€50	€1.00	€2.00	optional	2 / €50		755-5401-06
									Euro 7				optional	1 / €1.00	5 / €4.00	755-5401-07
									Euro 8					1 / €1.00	3 / €2.00	755-5401-08
									Euro 9					1 / €1.00	2 / €1.50	755-5401-09
									Euro 10					1 / €1.00	3 / €2.00	755-5401-10
									Euro 11					1 / €1.00	4 / €2.00	755-5401-11
									Euro 12					2 / €1.00	9 / €4.00	755-5401-12

12 **MATCH AWARD:** Set to **CREDIT**, **TICKET*** or **TOKEN***. Default is **CREDIT**. *read note under Std. Adjustment 3.

13 **MATCH PERCENTAGE:** Set between **0%** - **10%** or **OFF**. Default is **9%**. At **0%** the match display occurs at the end of the game but never awards a Credit. Set to **OFF**, no **Match Animation Feature** is shown.

14 **BALLS PER GAME:** Set between **02** - **05**. Default is **03**. Set the number of balls per game.

15 **TILT WARNINGS:** Set to **00**, **01** or **03**. Default is **01**. Set the number of Plumb Bob Tilt Switch closures before the ball in play is tilted.

16 **CREDIT LIMIT:** Set between **04** - **50**. Default is **30**. Set the maximum credits allowed.

17 **ALLOW HIGH SCORES:** Set to **YES** or **NO**. Default is **YES**. When set to **YES** if a player exceeds any 1 of the 4 High Scores, the player may receive an award (depending on Standard Adjustment 03, **Replay Award**). Set to **NO** to disable this feature. There are 5 High Scores that will allow the player to enter their initials (or name) (see Standard Adjustment 29, **High Score Initials**).

18 **GRAND CHAMPION AWARDS:** Set between **00** - **05**. Default is **01**. Set the number of awards, awarded for exceeding Level 1 (the highest of the five (5) Levels).

19 **HIGH SCORE #1 AWARDS:** Set between **00** - **03**. Default is **01**. Set the number of awards, awarded for exceeding Level 2.

20 **HIGH SCORE #2 AWARDS:** Set between **00** - **02**. Default is **00**. Set the number of awards, awarded for exceeding Level 3.

21 **HIGH SCORE #3 AWARDS:** Set between **00** - **01**. Default is **00**. Set the number of awards, awarded for exceeding Level 4.

22 **HIGH SCORE #4 AWARDS:** Set between **00** - **01**. Default is **00**. Set the number of awards, awarded for exceeding Level 5.

23 **GRAND CHAMPION SCORE:** Set between **1,000,000** - **9,999,000,000** or **00** (increments of 1M). Default is **50,000,000**. Set the desired **High Score Level** to which Level 1 may be achieved. A score higher than the default, cannot be reset by Standard Adjustment 28, **HSTD Reset Count**. The High Score will revert to the Default Score **ONLY** if a **Factory Reset** is done or the batteries are removed from the CPU/Snd. Bd.

24 **DEFAULT HIGH SCORE #1:** Set between **1,000,000** - **9,999,000,000** or **00** (increments of 1M). Default is **40,000,000**. Set the desired **High Score Level** to which Level 2 may be achieved. Read Std. Adj. 28.

25 **DEFAULT HIGH SCORE #2:** Set between **1,000,000** - **9,999,000,000** or **00** (increments of 1M). Default is **35,000,000**. Set the desired **High Score Level** to which Level 3 may be achieved. Read Std. Adj. 28.

26 **DEFAULT HIGH SCORE #3:** Set between **1,000,000** - **9,999,000,000** or **00** (increments of 1M). Default is **30,000,000**. Set the desired **High Score Level** to which Level 4 may be achieved. Read Std. Adj. 28.

27 **DEFAULT HIGH SCORE #4:** Set between **1,000,000** - **9,999,000,000** or **00** (increments of 1M). Default is **25,000,000**. Set the desired **High Score Level** to which Level 5 may be achieved. Read Std. Adj. 28.

28 **HSTD RESET COUNT:** Set between **100** - **9,900** or **OFF** (increments of 100). Default is **2,000**. **HSTD (High Score To Date)**. Set the number of games between "automatic resets of High Score Levels" to "Default Scores" for **ONLY** Standard Adj. 24-27, **Default High Score #1-#4**.

29 **HIGH SCORE INITIALS:** Set to **3 INITIALS** or **10 LETTER**. Default is **3 INITIALS**. When set to **3 INITIALS**, the player is allowed only 3 initials to input. When set to **10 LETTER NAME**, the player is allowed to enter 10 initials to input.

30 **FREE PLAY:** Set to **YES** or **NO**. Default is **NO**. When set to **YES**, no coins are required for **Game Play**.

31 **CUSTOM MESSAGE:** Set to **ON**, **CHANGE** or **OFF**. Default is **ON**. When set to **CHANGE**, a new message can be set or the old one can be edited (select the "+" Mini-Icon to change settings until "CHANGE" appears in the display, then select the ">>" Mini-Icon to access.). This adjustment can be accessed in two (2) ways by either selecting the "S.P.I." Icon and advancing to this Adjustment, or can be directly accessed by selecting the "ABCD CUST MSG" Icon in the **ADJUSTMENTS MENU**.

View the Custom Message Shortcut summary (end of this chapter) for how to enter text or symbols.

32 **FLASH LAMP POWER:** Set to **NORMAL**, **DIM** or **OFF**. Default is **NORMAL**. When set to **DIM**, the Flash Lamps impulse power is reduced by **25%** and when set to **OFF** the Flash Lamps will not flash.

Standard Adjustments 33-51 continued on the next page.





STANDARD ADJUSTMENT NAME: Definition

- 33 **COIL PULSE POWER:** Set to **NORMAL, HARD** or **SOFT**. Default is **NORMAL**. When set to **HARD**, the coil pulse power is **increased** by 12.5% of the normal pulse rate. When set to **SOFT** the coil pulse power is **decreased** by 12.5% of the normal pulse rate. This adj. is provided to compensate for *Low Line* or *High Line* voltage conditions where the solenoids (coils) appear to *kicking too weak or too hard*. Adjust as required.

- 34 **KNOCKER VOLUME:** Set to **NORMAL, LOW** or **OFF**. Default is **NORMAL**. When set to **LOW**, the volume is decreased 50%. When set to **OFF**, no sound is heard when the "knocker" is sounded.

- 35 **GAME RESTART:** Set to **YES** or **NO**. Default is **YES**. When set to **YES**, a new game may be started during any ball after the first ball is completed (*if credits are available*). Pressing the **Start Button** during the first ball will add additional players. When set to **NO**, the game disables the **Start Button** after the first ball until the final ball is in play. *Review Sec. 2, Chp. 1, GAME OPERATIONS & FEATURES, for details.*

- 36 **BILL VALIDATOR:** Set to **YES** or **NO**. Default is **NO**. When set to **YES**, in *Game Attract Mode* the Display will show an "Insert Bill Animation." When set to **NO**, the Display will show an "Insert Coin Animation."

- 37 **BKGRND (BACKGROUND) MUSIC VOLUME:** Set between **01 - 15**. Default is **01**. After volume is set via Portals Service Buttons (*see Section 3, Chapter 1, PORTALS™SERVICE MENU INTRODUCTION*) this adjustment can be utilized to adjust the background music (*1 all the way on, 15 all the way off*) while keeping the Special Sound FX the same level.

- 38 **FREEZE TIME (BALL SAVE):** Set to **OFF, 0:01-0:15** or **AUTO**. Default is **OFF**. When set to **OFF** this feature is unavailable. Set between **0:01** through **0:15** (*single increments*) for the ball to be sent back into play if the time set is not met (*per ball*). Set to **AUTO** to automatically adjust the Freeze Timer based on the average ball time.

- 39 **////// UK ONLY //// Dip Switch Must Be Set //// UK POST SAVE ENABLED:** Set to **YES** or **NO**. Default is **NO**, (*UK Default is YES*). When set to **YES** this feature is available when lit. Set to **NO** to disable this feature. (*UK Games have Outlane/Center Post Save Devices which are accessed in differently; Non-UK Games cannot adjust this setting.*)

- 40 **TIMED PLUNGER:** Set to **OFF** or **0:15 - 1:00**. Default is **OFF**. When set to **0:15** to **1:00**, the plunger will "Autoplunge" the ball (*at the time set*) when the ball is at the beginning of play, awaiting the skill shot by the player.

- 41 **FLIPPER BALL LAUNCH:** Set to **DISABLED, LEFT FLIPPER, RIGHT FLIPPER, EITHER FLIPPER** or **BOTH FLIPPERS**. Default is **DISABLED**. This feature allows the player to operate the *Auto Ball Launch* with the **FLIPPER BUTTON(S)** depending on which setting is chosen.

- 42 **COINDOOR BALL SAVER:** Set to **YES** or **NO**. Default is **NO**. When set to **NO**, this feature is not available. When set to **YES**, this feature allows the Coin Door to be opened during game play; the ball will drain but the game will be placed "on hold". When the Coin Door is closed, the pinball will return to the Shooter Lane, and the game will resume.

- 43 **COMPETITION MODE:** Set to **YES** or **NO**. Default is **NO**. When set to **NO**, this feature is not available. If an Install of either \$.50 or Free Play Competition was made (*changing the default to YES*), and was changed back to **NO**, the **COMPETITION MODE** will be turned **OFF** (*see Section 3, Chapter 5, GO TO INSTALLS MENU, \$. 50 or Free Play Competition*). Set to **YES**, this feature is available (*required for Competition Modes*); this feature will equalize random game features and global score values during multi-player games.

- 44 **CONSOLATION BALL:** Set to **YES** or **NO**. Default is **YES**. When set to **YES**, the **EXTRA BALL** (*Playfield Light Insert, location varies*) will be lit on the last ball in play, if certain programming criteria is met.

- 45 **FAST BOOT:** Set to **YES** or **NO**. Default is **NO**. When set to **NO**, this feature is not available and will display all normal Power-Up screens. When set to **YES**, the game will not display the normal informative Power-Up screens, specifically the CPU Version screen and the Location/Game ID screen. Regardless of the setting, normal Power-Up safety checks are still performed.

- 46 **Q24 OPTION:** Set to **COIN METER, TOKEN DISPENSER** or **KNOCKER**. Default is **COIN METER**. This Coil (Solenoid) Location is left "open" at the Factory to allow for these optional Mechanisms to be added to the game. If selecting **TOKEN DISPENSER**, Standard Adjustments 03, 06 & 12 should be changed to **TOKEN**. *Call Technical Support at 1-800-542-5377 if more information is required on this option.*

- 47 **TICKET DISP. INSTALLED:** Set to **YES** or **NO**. Default is **NO**. *This adjustment is required only for games which have an optional Deltronics (DL-1275 PCB Style) Ticket Dispenser Installed. Unique CPU Sound Board Dip Switch (Sw. 300) Setting required, which also changes the Default to YES.*

- 48 **ALLOW PLAYER COMP. MODE:** Set to **YES** or **NO**. Default is **YES**. **Competition Mode** unrandomizes feature events, and standardizes game play and rule sets (*varies from game to game*) for fair competitions. With adequate credit, to enter **Competition Mode**, hold the **Flipper Button** in while pressing the **Start Button**. **Watch the Dot Display for more details** (*rules and operation are subject to change*). General rules are covered in the Instruction Card. Other *Hints and/or Rules* can be made known on this game either visually (*the Dot Display or Flashing Light Inserts*) or can be audible.

- 49 **TECH ALERT WARNING:** A Portals™ Function. *Review Sec. 3, Chp. 2, GO TO DIAGNOSTICS MENU, Page 25, regarding Technician Alerts and its' functions.* Set to **NEVER, POWERUP, COIN DOOR** or **POWERUP AND COIN DOOR**. Default is **NEVER**. When set to **NEVER**, the *Tech Report Alert display will not appear upon Power-Up or opening the Coin Door, if the game detects any problems*. When set to **POWERUP**, the display will appear only upon Power-Up (*if problems detected*). When set to **COIN DOOR**, the display will appear only when the Coin Door is opened (*if problems detected*). When set to **POWERUP AND COIN DOOR**, the display will appear upon Power-Up and if the Coin Door is opened (*if problems detected*).

- 50 **LOCATION ID:** Set between **00** to **9999**. Default is **00**. This adjustment allows the operator to assign a location identification number to the audit print-out sheet. (*Will not be affected by Factory Reset.*)

- 51 **GAME ID:** Set between **00** to **9999**. Default is **00**. This adjustment allows the operator to assign a game identification number to the audit print-out sheet. (*Will not be affected by Factory Reset.*)

Sec. 3: Adjustments





Feature Adjustments (01-36)

To initiate, from the **ADJUSTMENTS MENU**, select the "SPP" *Icon* with either the **Red "LEFT"** or **Green "RIGHT" Buttons** and press the **Black "ENTER" Button**. Select and *activate* either of the ">>" *Mini-Icons* to view the next or previous Adjustment in this group. Select and *activate* either of the "-" or "+" *Mini-Icons* to change the setting, if desired (*the Default Setting is noted in the definitions below*). The display will describe the **Adjustment Number**, **Adjustment Name** and the **Current Adjustment Setting**. The current Adjustment will remain in the display until the next Adjustment is view or when this Menu is exited.

Nr.	FEATURE ADJUSTMENT NAME: Definition
01	3 BANK DIFFICULTY: Set to EASY, MODERATE or HARD . Default is HARD . Determines how this Feature is started and played. Adjusts the difficulty of the Captive Ball spotting 3-Bank Targets. EASY will cause the Captive Ball to always spot a target. HARD will cause the Captive Ball to spot a target only when it can not advance the <i>Daredevil Feature</i> . MODERATE will cause EASY behavior the first time through Captive Ball Awards, then HARD behavior after that.
02	DAREDEVIL DIFFICULTY: Set to EXEASY, EASY, MODERATE, HARD or EXHARD . Default is MODERATE . Determines how this Feature is started and played. Adjusts how <i>Daredevil Modes</i> are lit. EXTRA EASY will light all <i>Modes</i> with each ball. EASY will light all <i>Modes</i> once, then light additional <i>Modes</i> at Ball Start if none are already lit. MODERATE will light one <i>Mode</i> at Ball Start if none are already lit. HARD will light one <i>Mode</i> one time. EXTRA HARD will never light a <i>Mode</i> for free.
03	# OF RAMPS FOR 1ST EB: Set between 06 to 14 . Default is 10 . Sets the maximum number of <i>Right Ramp Shots</i> required to light the Extra Ball (EB) for the first time.
04	# OF RAMPS NEXT EBS: Set between 20 to 90 . Default is 50 . Sets the maximum number of <i>additional Ramp Shots</i> required to light the Extra Ball (EB) for <i>subsequent</i> EBs (e.g. <i>Setting of 50 cause EBs to be lit at the initial 10 Ramps, then 60, 110, etc.</i>).
05	MAX EBS FROM RAMP: Set between 00 to 10 . Default is 04 . Sets the maximum number of Extra Balls (EBs) that may be earned from the Right Ramp.
06	RAMP EB MEMORY: Set to YES or NO . Default is YES . When set to YES , this feature bonus (<i>Extra Ball (EB) lit from the Right Ramp</i>) will be retained in memory from <i>ball-to-ball</i> for the same player. When set to NO , this feature will go out at the end of each ball.
07	1ST RAMP TREEHOUSE: Set between 02 to 10 . Default is 05 . Sets the number of <i>Right Ramp Shots</i> required to light the <i>Treehouse of Horror Mode</i> for the first time.
08	NEXT TREEHOUSE: Set between 05 to 20 . Default is 10 . Sets the number of <i>Right Ramp Shots</i> required to light the <i>Treehouse of Horror Mode</i> <i>subsequent</i> times (e.g. <i>Default settings cause Treehouse of Horror Mode to be lit at 5 Ramps, then 15 Ramps, then 25 ..., etc.</i>)
09	1ST COUCH LOCKS UNLIT: Set between 01 to 05 . Default is 02 . Sets the first <i>Couch Multiball</i> where <i>Locks</i> start off unlit (i.e. <i>the player must earn locks; setting of 2 means the "2nd" Multiball</i>).
10	COUCH MB DIFFICULTY: Set to EXEASY, EASY, MODERATE, HARD or EXHARD . Default is EXTRA EASY . Determines how this Feature is started and played. Sets the difficulty of lighting <i>Locks</i> for <i>Couch Multiball (MB)</i> . EXTRA EASY means targets can be hit in any order, and the <i>Locks</i> are stackable. EASY means targets can be hit in any order, but balls must be <i>Locked</i> before the next <i>Lock</i> can be lit (unstackable). MODERATE means the targets must be hit in order (<i>LIGHT then LOCK</i>), unstackable. HARD means targets must be hit 2 times each, any order, unstackable. EXTRA HARD means targets must be hit <i>LIGHT</i> twice, then <i>LOCK</i> twice, unstackable.
11	TV LIGHTING DIFFICULTY: Set to EXEASY, EASY, MODERATE, HARD or EXHARD . Default is EASY . Determines how this Feature is started and played. Sets how hard it is to start <i>TV Modes</i> . EXTRA EASY means the <i>TV Mode</i> is <i>ALWAYS</i> lit. EASY means the <i>TV Mode</i> is always lit at Ball Start. MODERATE means the <i>TV Mode</i> starts off lit, but <i>does not automatically relight</i> at Ball Start. HARD means the <i>TV Mode</i> starts off unlit. EXTRA HARD means the <i>TV Mode</i> will start off at Ball Start <i>regardless if it was lit before or not</i> .
12	MYSTERY LIGHTING DIFF.: Set to EXEASY, EASY, MODERATE, HARD or EXHARD . Default is MODERATE . Determines how this Feature is started and played. Sets how hard the <i>Mystery Feature (clean the garage)</i> is. The settings are the identical to Feature Adjustment 11, TV Light Difficulty .
13	MYSTERY EB MEMORY: Set to YES or NO . Default is NO . When set to YES , this feature bonus (<i>Extra Ball (EB) Lit from the Mystery Award</i>) will be retained in memory from <i>ball-to-ball</i> for the same player. When set to NO , this feature will go out at the end of each ball.
14	MYSTERY SPECIAL MEMORY: Set to YES or NO . Default is NO . When set to YES , this feature bonus (<i>Special Lit from the Mystery Award</i>) will be retained in memory from <i>ball-to-ball</i> for the same player. When set to NO , this feature will go out at the end of each ball.
15	MAIN TIMER DIFFICULTY: Set to EXEASY, EASY, MODERATE, HARD or EXHARD . Default is MODERATE . Determines how this Feature is started and played. Sets how much time the player gets for every <i>Scoring Mode</i> as well as how much time is added when MORE TIME is hit. <i>Range: EXEASY provides more time... EXHARD provides less time. Time allotment may vary.</i>
16	1ST I&S WITH DROPS: Set between 01 to 05 . Default is 02 . Sets the first <i>Itchy & Scratchy (I&S) Multiball</i> where all Drop Targets must be knocked down before the <i>I&S Saucer Shots</i> count (<i>setting of 2 means the "2nd" Multiball</i>).
17	1ST I&S DROPS RESET: Set between 01 to 05 . Default is 03 . Sets the first <i>Itchy & Scratchy Multiball</i> where the Drop Targets will reset after a period of time, if they are not all knocked down (<i>setting of 3 means the "3rd" Multiball</i>).
18	1ST I&S SHOT TWICE: Set between 01 to 05 . Default is 01 . Sets the first <i>Itchy & Scratchy Multiball</i> where the Saucer must be <i>shot first</i> in order to light <i>I&S Multiball (setting of 1 means the "1st" Multiball)</i> .

Sec. 3: Adjustments

Feature Adjustments 19-36 continued on the next page.





FEATURE ADJUSTMENT NAME: Definition

- 19 **ENABLE REVERSED FLIPPERS:** Set to **YES** or **NO**. Default is **YES**. When set to **YES**, the game is allowed to reverse flipper control during Springfield Mystery Spot.
- 20 **GARAGE DOOR DIFF:** Set to **EXEASY, EASY, MODERATE, HARD** or **EXHARD**. Default is **EASY**. Determines when the garage door will automatically reopen when the player is leaving the *Upper Mini-Playfield*, either by locking a ball in the *couch* or by exiting onto the *Monorail Ramp*. **EXTRA EASY** means the door will continue to open until Couch Multiball is achieved. **EASY** means the door will continue to open until a ball has been locked in the couch. **MODERATE** means the door will continue to open until a ball has been locked in the couch or a TV Award has been given. **HARD** means the door will continue to open until a ball has been locked in the couch or a TV Award has been given or the Mystery has been relit. **EXTRA HARD** means the door will never automatically reopen.
- 21 **OTTO LIGHTING DIFF:** Set to **EXEASY, EASY, MODERATE, HARD** or **EXHARD**. Default is **EASY**. Determines how this Feature is started and played. Sets how hard it is to start *Otto 2X Scoring Modes*. *The settings are the identical to Feature Adjustment 11, TV Light Difficulty*.
- 22 **SHOW UPPER FLIPPERS:** Set to **YES** or **NO**. Default is **YES**. When set to **YES**, the game will *flip (actuate the coils)* the Upper Flippers in an attempt to get players to notice them when they are being fed for the first time. If the player is about to have a ball kicked out of the Upper Right Saucer, the game will *flip* the Lower Playfield Mid Right Flipper 5 times. If the player is about to have a ball kicked up to the living room, the game will *flip* the Upper Playfield Left Flipper 5 times. *This will not occur if the first feed to a Flipper is during any Multiball Mode*.
- 23 **CBG HURRY UP DIFFICULTY:** Set to **EXEASY, EASY, MODERATE, HARD** or **EXHARD**. Default is **MODERATE**. Determines how this Feature is started and played. Controls the speed at which the *Comic Book Guy (CBG) Hurry-Up Feature* counts down. *Difficulty will vary*.
- 24 **# OF NVS FOR 1ST EB:** Set between **05** to **20**. Default is **10**. Sets the number of *Nuclear Values (NVs)* required to light the Extra Ball (EB) for the first time.
- 25 **# OF NVS NEXT EBS:** Set between **20** to **90**. Default is **50**. Sets the number of *additional Nuclear Values (NVs)* required to light the Extra Ball (EB) for *subsequent EBs (e.g. Setting of 50 cause Extra Balls to be lit at the initial 10 NVs, then 60, 110 ..., etc.)*.
- 26 **MAX EBS FROM NUCLEAR:** Set between **00** to **10**. Default is **04**. Sets the maximum number of Extra Balls (EBs) that may be earned from the *Nuclear Value*.
- 27 **NUCLEAR EB MEMORY:** Set to **YES** or **NO**. Default is **YES**. When set to **YES**, this feature bonus (*Extra Ball (EB) lit from Nuclear Value*) will be retained in mem. from *ball-to-ball* for the same player. ... **NO**, this feature will go out at the end of each ball.
- 28 **COUCH EB DIFFICULTY:** Set to **EASY, MODERATE** or **HARD**. Default is **EASY**. Determines how this Feature is started and played. Sets how hard it is to earn an Extra Ball (EB) from *Couch Multiball*. **EASY** means only a *Couch Super Jackpot* is required. **MODERATE** means all *Jackpots* must be completed before the *Super Jackpot* to light the Extra Ball. **HARD** means all *Jackpots* must be shot perfectly (*singles then doubles then triple*) before the *Super Jackpot* to light the Extra Ball (EB).
- 29 **COUCH EB MEMORY:** Set to **YES** or **NO**. Default is **NO**. When set to **YES**, this feature bonus (*Extra Ball (EB) lit from Couch Multiball*) will be retained in memory from *ball-to-ball* for the same player. ... **NO**, this feature will go out at the end of each ball.
- 30 **CBG EB MEMORY:** Set to **YES** or **NO**. Default is **NO**. When set to **YES**, this feature bonus (*Extra Ball (EB) lit from Comic Book Guy (CBG) Hurry-Up Feature*) will be retained in memory from *ball-to-ball* for the same player. When set to **NO**, this feature will go out at the end of each ball.
- 31 **CBG SPECIAL MEMORY:** Set to **YES** or **NO**. Default is **NO**. When set to **YES**, this feature bonus (*Special lit from Comic Book Guy (CBG) Hurry-Up Feature*) will be retained in memory from *ball-to-ball* for the same player. When set to **NO**, this feature will go out at the end of each ball.
- 32 **SDMEWM SPECIAL MEMORY:** Set to **YES** or **NO**. Default is **NO**. When set to **YES**, this feature bonus (*Special lit from Super Duper Mega Extreme Wizard Mode (SDMEWM)*) will be retained in memory from *ball-to-ball* for the same player. When set to **NO**, this feature will go out at the end of each ball.
- 33 **MONORAIL INTERVAL:** Set between **03** to **07**. Default is **05**. Sets the max. number of *Monorail Rides* required to earn awards.
- 34 **ADULT CONTENT ENABLED:** Set to **YES** or **NO**. Default is **YES**. Set to **NO** to disable "adult content" in both audible (sounds and/or words). Visual (dot display graphics) may be included, if present.
- 35 **HOLD COUCH LOCKS:** Set to **NEVER, 1-PLAYER GAMES** or **ALWAYS**. Default is **1-PLAYER GAMES**. Set to **NEVER** means the couch will never hold locks between games and will kick balls out at the Game End. **1-PLAYER GAMES** means the couch will hold locks between games and allow players to "steal" locks from previous games, but only in a *1-Player Game (so there isn't an advantage in Multiplayer Games)*. **ALWAYS** means the couch will always hold locks between games **AND** players, and allow players to "steal" locks even in *Multiplayer Games*. (*This adjustment is ignored when Competition Mode is on (treated as NEVER)*). In *Tournament Games*, players must always earn Couch Multiball by making 3 locks. In the case that a *Tournament Game Player* is starting a game with 1 or more balls already in the lock, balls will be passed-through as in a *Multiplayer Game* when the couch is full (*or the Installed number of balls is maxed out*).
- 36 **ALLOW VOLUME EFFECTS:** Set to **YES** or **NO**. Default is **YES**. Set to **NO** to disable this feature. Set to **YES**, the volume will automatically adjust louder and softer, depending on which feature (or certain events) is being played and/or how well the player is performing (or awards received). *Note: If the game volume is set to 0, this adjustment will be treated as if set to NO.*

For further customization of Game Play Difficulty or Game Play Type or how to RESET ONLY the Adjustments, see Section 3, Chapter 5, GO TO INSTALLS MENU.

Sec. 3: Adjustments





Custom Message

To go directly to **Standard Adjustment 31, Custom Message**, from the **ADJUSTMENT MENU**, select the "CUST MSG" *Icon* with either the **Red "LEFT"** or **Green "RIGHT"** Buttons and press the **Black "ENTER"** Button. At the top left corner of the Display, the letter **A** is indicated (*blinking*) in the first available position (*Thirty-Six (36) characters including spaces are available*). Vary the letter(s) by operating the Left and Right Flipper Buttons (or **"RED"** or **"GREEN"** Buttons). With the desired letter indicated, depress the **Start Button** to lock in the letter and advance to the next character. Repeat this procedure until the desired message is completed in the display. Select the "<" or ">" characters to back-space (*erase*) and/or to move forward in an already typed message. After completion, press the **"BLACK"** Button, "REQUEST INSTALLED" is indicated and then exits this sub-menu.

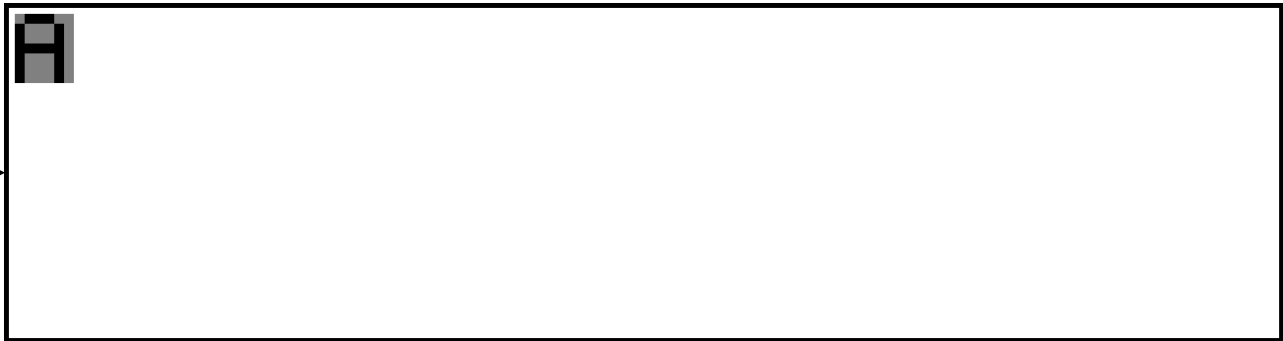
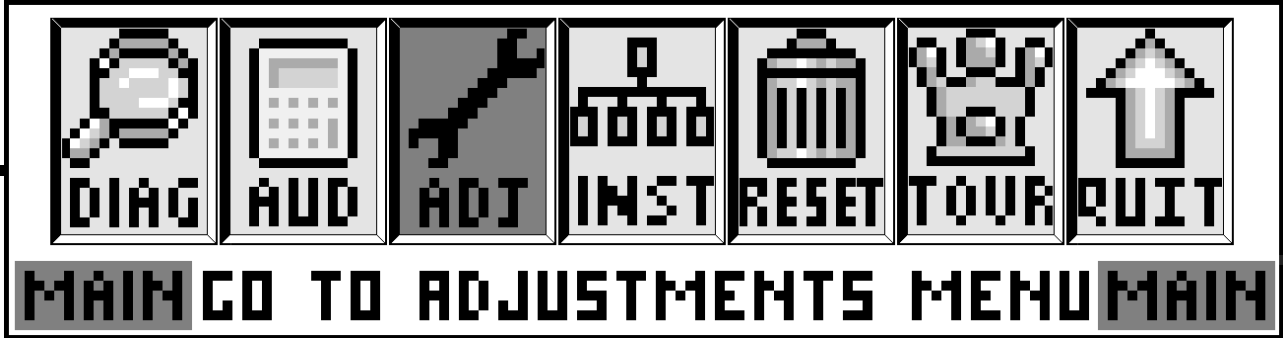

Sec. 3: Adjustments



For further customization of Game Play Difficulty or Game Play Type or how to **RESET ONLY** the Adjustments, see Section 3, Chapter 5, **GO TO INSTALLS MENU**.



Go To Installs Menu

Overview

The Portals™ Service Menu System provides **14 Installs** to vary **Game Play Difficulty** or **Game Play Type** and **Install Factory**.



Important: The **Coin Door** must be **OPEN** allowing the **Memory Protect Switch** to be disabled, so any **Install** changes can be made.



For **detailed customization** or to check current **Adjustments Defaults** (either changed by **YOU** in the **Adjustments Menu** or by this **Installs Menu** or for **Factory Default Settings**), see **Section 3, Chapter 4, GO TO ADJUSTMENTS MENU**. **Important: Before preceding**, write down any **previously changed Adjustment Defaults**. After completing one or more of the **Installs** in this Chapter, go back to the **ADJUSTMENTS MENU** to see which **Standard and/or Feature Adjustments** have changed (*Feature Adjustments and/or settings are subject to change during production, and may differ than what is described in the tables at the end of this chapter*). If the settings are not to your liking, perform **one** of the following:

- 1.: **Manually** change the **Standard & Feature Adjustments** Settings (perform task in the **ADJUSTMENTS MENU**, see **Section 3, Chapter 4, GO TO ADJUSTMENTS MENU**).
- 2.: **Install Factory** (see **Page 49, end of this chapter**) to reset all of the **Standard & Feature Adjustments** back to the **Factory Default Settings**.

Multiple **Installs** can be set to vary game play; however, for **Installs** that have *one or more* Adjustments in common, the **last** "Install" selected & **activated**, will **supersede** any previously changed Adjustment(s) from any prior **Installs**. Any adjustments which you changed and are not affected by the Install will remain as set.

For example, if you want a **5-BALL Game** set to **EXTRA EASY**: Select and **activate** the "5BAL" **Icon** first (which will typically change any **Feature** Difficulty Adjustments to **HARD**), then select & **activate** the "X.EZ" **Icon** to **change back** the Difficulty Adjustments to **EXTRA EASY**. However, if the "X.EZ" **Icon** was selected & **activated** first, then the "5BAL" **Icon** was selected & **activated**, the game will be set to a **5-BALL Game** set to **HARD**.

EXPLANATION & USAGE OF COMMON LARGE ICONS USED IN THIS MENU:



These **non-selectable** icons appear in the selected Menu only when there are **MORE** icons to the **LEFT** or to the **RIGHT** available for selection.



Select and activate to return to the **PREVIOUS** Menu.



Select and activate to **QUIT**, exits & returns to the **Attract Mode**.



Select and activate to view **HELP** Screens of the current Menu*.

WARNING:
Selection & activation of the "Install Factory" Icon, will change all Adjustments & Installs to the Factory Default!

* **Help Note:** An explanation of each Icon at that menu level will cycle continuously. To exit a display where no icons are available for selection, pressing any button will exit the display.



GO TO INSTALLS MENU

After entering **Portals™**, the **MAIN MENU** now appears. Select the "INST" **Icon** in the **MAIN MENU** with either the **Red "LEFT"** or **Green "RIGHT"** Buttons (the **Flipper Buttons** operates in the same manner) and press the **Black "ENTER"** Button (the **Start Button** operates in the same manner). The **INSTALLS MENU** appears. Continue through this chapter for the explanation & usage of the **Icons** in the **INSTALLS MENU**.



Install Extra Easy

To initiate, from the **INSTALLS MENU**, select the "X.EZ" **Icon** with either the **Red "LEFT"** or **Green "RIGHT"** Buttons and press the **Black "ENTER"** Button. **Game Play Difficulty** is set to **EXTRA EASY**. "REQUEST INSTALLED" is indicated and returns to the **INSTALLS MENU** with the "X.EZ" **Icon** flashing. *Only the Feature Adjustments which changed, are listed in the Overview of Feature Adjustment Changes (Pg. 50).*



Install Easy

To initiate, from the **INSTALLS MENU**, select the "EASY" **Icon** with either the **Red "LEFT"** or **Green "RIGHT"** Buttons and press the **Black "ENTER"** Button. **Game Play Difficulty** is set to **EASY**. "REQUEST INSTALLED" is indicated and returns to the **INSTALLS MENU** with the "EASY" **Icon** flashing. *Only the Feature Adjustments which changed, are listed in the Overview of Feature Adjustment Changes (Page 50).*





Install Normal (Factory Default Settings)

To initiate, from the **INSTALLS MENU**, select the "FACT" *Icon* with either the **Red "LEFT"** or **Green "RIGHT"** Buttons and press the **Black "ENTER"** Button. **Game Play Difficulty** is set to **MODERATE**. "REQUEST INSTALLED" is indicated and returns to the **INSTALLS MENU** with the "FACT" *Icon* flashing. *Only the Feature Adjustments which changed, are listed in the Overview of Feature Adjustment Changes (Page 50).*



Install Hard

To initiate, from the **INSTALLS MENU**, select the "HARD" *Icon* with either the **Red "LEFT"** or **Green "RIGHT"** Buttons and press the **Black "ENTER"** Button. **Game Play Difficulty** is set to **HARD**. "REQUEST INSTALLED" is indicated and returns to the **INSTALLS MENU** with the "HARD" *Icon* flashing. *Only the Feature Adjustments which changed, are listed in the Overview of Feature Adjustment Changes (Page 50).*



Install Extra Hard

To initiate, from the **INSTALLS MENU**, select the "X.HD" *Icon* with either the **Red "LEFT"** or **Green "RIGHT"** Buttons and press the **Black "ENTER"** Button. **Game Play Difficulty** is set to **EXTRA HARD**. "REQUEST INSTALLED" is indicated and returns to the **INSTALLS MENU** with the "X.HD" *Icon* flashing. *Only the Feature Adjustments which changed, are listed in the Overview of Feature Adjustment Changes (Page 50).*



Install 3-Ball

To initiate, from the **INSTALLS MENU**, select the "3BAL" *Icon* with either the **Red "LEFT"** or **Green "RIGHT"** Buttons and press the **Black "ENTER"** Button. **Game Play Type** is set to **3-BALL PLAY**. "REQUEST INSTALLED" is indicated and returns to the **INSTALLS MENU** with the "3BAL" *Icon* flashing. *Only the Standard & Feature Adjustments which changed, are listed in the Overview of Standard & Feature Adjustment Changes (Pages 49 & 50).*



Install 5-Ball

To initiate, from the **INSTALLS MENU**, select the "5BAL" *Icon* with either the **Red "LEFT"** or **Green "RIGHT"** Buttons and press the **Black "ENTER"** Button. **Game Play Type** is set to **5-BALL PLAY**. "REQUEST INSTALLED" is indicated and returns to the **INSTALLS MENU** with the "5BAL" *Icon* flashing. *Only the Standard & Feature Adjustments which changed, are listed in the Overview of Standard & Feature Adjustment Changes (Pages 49 & 50).*



\$.50 Competition (a.k.a. IFPA)

To initiate, from the **INSTALLS MENU**, select the "PAY" *Icon* with either the **Red "LEFT"** or **Green "RIGHT"** Buttons and press the **Black "ENTER"** Button. **Game Play Type** is set to **TOURNAMENT PAY MODE**. "REQUEST INSTALLED" is indicated and returns to the **INSTALLS MENU** with the "PAY" *Icon* flashing. *Only the Standard Adjustments which changed, are listed in the Standard Adjustment Changes (Page 49).*



Free Play Competition (a.k.a. EXPO or PAPA)

To initiate, from the **INSTALLS MENU**, select the "FREE" *Icon* with either the **Red "LEFT"** or **Green "RIGHT"** Buttons and press the **Black "ENTER"** Button. **Game Play Type** is set to **TOURNAMENT FREE MODE**. "REQUEST INSTALLED" is indicated and returns to the **INSTALLS MENU** with the "FREE" *Icon* flashing. *Only the Standard Adjustments which changed, are listed in the Overview of Standard Adjustment Changes (Page 49).*



Install Home Play

To initiate, from the **INSTALLS MENU**, select the "HOME" *Icon* with either the **Red "LEFT"** or **Green "RIGHT"** Buttons and press the **Black "ENTER"** Button. **Game Play Type** is set to **NORMAL HOME PLAY**. "REQUEST INSTALLED" is indicated and returns to the **INSTALLS MENU** with the "HOME" *Icon* flashing. *Only the Standard Adjustments which changed, are listed in the Overview of Standard Adjustment Changes (Page 49).*





Film Star Reset

To initiate, from the **INSTALLS MENU**, select the "STAR" *Icon* with either the **Red "LEFT"** or **Green "RIGHT" Buttons** and press the **Black "ENTER" Button**. **Game Play Type** is set to **EASY HOME PLAY**. "REQUEST INSTALLED" is indicated and returns to the **INSTALLS MENU** with the "STAR" *Icon* flashing. *Only the Standard & Feature Adjustments which changed, are listed in the Overview of Standard Adjustment Changes (below) and in the Overview of Feature Changes (next page).*



Install Novelty

This setting is recommended where **local laws restrict certain game features**.

To initiate, from the **INSTALLS MENU**, select the "NOV" *Icon* with either the **Red "LEFT"** or **Green "RIGHT" Buttons** and press the **Black "ENTER" Button**. **Game Play Type** is set to **RESTRICTED PLAY**. "REQUEST INSTALLED" is indicated and returns to the **INSTALLS MENU** with the "NOV" *Icon* flashing. *Only the Standard Adjustments which changed, are listed in the Overview of Standard Adjustment Changes (below).*



Install Add-A-Ball

This setting is recommended where **local laws restrict certain game features**.

To initiate, from the **INSTALLS MENU**, select the "A.A.B" *Icon* with either the **Red "LEFT"** or **Green "RIGHT" Buttons** and press the **Black "ENTER" Button**. **Game Play Type** is set to **RESTRICTED PLAY**. "REQUEST INSTALLED" is indicated and returns to the **INSTALLS MENU** with the "A.A.B" *Icon* flashing. *Only the Standard Adjustments which changed, are listed in the Overview of Standard Adjustment Changes (below).*



Install Factory (ONLY affects all Adjustments/Installs)

To initiate, from the **INSTALLS MENU**, select the "FACT" *Icon* with either the **Red "LT"** or **Green "RT" Buttons** and press the **Black "ENT" Button**. **▲ All Installs will be reset to the Factory Default Settings.** "REQUEST INSTALLED" is indicated and the **Service Menu** is exited, returning to the **Attract Mode**. All Standard & Feature Adjustments which were changed in the **INSTALLS** or **ADJUSTMENTS MENU** are returned to the **Factory Defaults** (see the **Adjustment Tables in Sec. 3, Chp. 4, GO TO ADJUSTMENTS MENU**).



Overview of Standard Adjustment Changes with selection of these Installs:



Nr.	STANDARD ADJUSTMENT NAME	INSTALL 3-BALL	INSTALL 5-BALL	\$.50 COMPETITION *	FREE PLAY COMP. *	INSTALL HOME PLAY	FILM STAR RESET	INSTALL NOVELTY	INSTALL ADD-A-BALL
01	REPLAY TYPE							NONE	
03	REPLAY AWARD								EX. BALL
08	FREE GAME LIMIT							NO FREE...	NO FREE...
09	EXTRA BALL LIMIT					UNLIMITED	UNLIMITED	NO EXTRA...	UNLIMITED
10	EXTRA BALL PERCENTAGE					30%			
11	GAME PRICING			USA 5					
13	MATCH PERCENTAGE					10%		OFF	OFF
14	BALLS PER GAME	03	05						
15	TILT WARNINGS			02	02				
18	GRAND CHAMPION AWARDS							00	00
19	HIGH SCORE #1 AWARDS							00	00
20	HIGH SCORE #2 AWARDS							00	00
21	HIGH SCORE #3 AWARDS							00	00
22	HIGH SCORE #4 AWARDS							00	00
30	FREE PLAY			NO	YES	YES	YES		
35	GAME RESTART			NO	NO				
42	COINDOOR BALL SAVER**			YES	YES	YES	YES		
43	COMPETITION MODE***			YES	YES				

* If Competition Mode was set, it is suggested to "Install Factory" to restore all Adjustments (Factory Default); then to recustomize, if desired.
** Note 1: Adjustment 42 Default will not change; Installing \$.50 Competition will override this Adjustment regardless of the setting.
*** Note 2: If Adjustment 43 is changed back to NO after this Install, the Competition Mode Install will be canceled (turned off).

Overview of Feature Adjustment Changes ... on the next page.

Go To
Installs Menu



Overview of Feature Adjustment Changes with selection of these Installs:



Nr.	FEATURE ADJUSTMENT NAME *	INSTALL EXTRA EASY	INSTALL EASY	INSTALL NORMAL (FACTORY)	INSTALL HARD	INSTALL EXTRA HARD	INSTALL 3-BALL **	INSTALL 5-BALL **	FILM STAR RESET **
01	3 BANK DIFFICULTY	EASY	MODERATE	HARD	HARD	HARD	HARD	HARD	EASY
02	DAREDEVIL DIFFICULTY	EX. EASY	EASY	MODERATE	HARD	EX. HARD	MODERATE	HARD	EX. EASY
03	# OF RAMPS FOR 1ST EB	06	08	10	12	14	10	12	06
04	# OF RAMPS NEXT EBS	30	40	50	60	70	50	60	30
05	MAX EBS FROM RAMP	10	06	04	03	02	04	03	10
06	RAMP EB MEMORY	YES	YES	YES	YES	NO	YES	YES	YES
07	1ST RAMP TREEHOUSE	03	04	05	06	07	05	06	03
08	NEXT TREEHOUSE	06	08	10	12	14	10	12	06
09	1ST COUCH LOCKS UNLIT	03	02	02	01	01	02	01	03
10	COUCH MB DIFFICULTY	EX. EASY	EX EASY	EX EASY	EX EASY	EASY	EX EASY	EX EASY	EX. EASY
11	TV LIGHTING DIFFICULTY	EX. EASY	EASY	EASY	MODERATE	MODERATE	EASY	MODERATE	EX. EASY
12	MYSTERY LIGHTING DIFF.	EASY	MODERATE	MODERATE	MODERATE	HARD	MODERATE	MODERATE	EASY
13	MYSTERY EB MEMORY	YES	YES	NO	NO	NO	NO	NO	YES
14	MYSTERY SPECIAL MEMORY	YES	NO	NO	NO	NO	NO	NO	YES
15	MAIN TIMER DIFFICULTY	EX. EASY	EASY	MODERATE	HARD	EX. HARD	MODERATE	HARD	EX. EASY
16	1ST I&S WITH DROPS	04	03	02	01	01	02	01	04
17	1ST I&S DROPS RESET	06	04	03	02	01	03	02	06
18	1ST I&S SHOT TWICE	02	02	01	01	01	01	01	02
20	GARAGE DOOR DIFF	EX. EASY	EX. EASY	EASY	MODERATE	HARD	EASY	MODERATE	EX. EASY
21	OTTO LIGHTING DIFF	EX. EASY	EASY	EASY	MODERATE	MODERATE	EASY	MODERATE	EX. EASY
23	CBG HURRY UP DIFFICULTY	EX. EASY	EASY	MODERATE	HARD	EX. HARD	MODERATE	HARD	EX. EASY
24	# OF NVS FOR 1ST EB	05	08	10	12	15	10	12	05
25	# OF NVS NEXT EBS	25	40	50	60	75	50	60	25
26	MAX EBS FROM NUCLEAR	10	06	04	03	02	04	03	10
27	NUCLEAR EB MEMORY	YES	YES	YES	YES	NO	YES	YES	YES
28	COUCH EB DIFFICULTY	EASY	EASY	EASY	MODERATE	MODERATE	EASY	MODERATE	EASY
29	COUCH EB MEMORY	YES	YES	NO	NO	NO	NO	NO	YES
30	CBG EB MEMORY	YES	YES	NO	NO	NO	NO	NO	YES
31	CBG SPECIAL MEMORY	YES	NO	NO	NO	NO	NO	NO	YES
32	SDMEWM SPECIAL MEMORY	YES	NO	NO	NO	NO	NO	NO	YES
33	MONORAIL INTERVAL	03	04	05	06	07	05	06	03
35	HOLD COUCH LOCKS	1-PLAYER...	1-PLAYER...	1-PLAYER...	NEVER	NEVER	1-PLAYER...	NEVER	1-PLAYER...

* Feature Adjustments and/or settings are subject to change. **Feature Adjustments which are not affected by any Installs are: 19 & 22.**
 ** Install 3-Ball, Install 5-Ball & Film Star Reset have Standard Adjustment(s) which change (see table on previous page).

Sec. 3: Go To Installs

For how to RESET Audits (also can RESET High Scores, Credits or Reset All Adjustments), see Section 3, Chapter 6, GO TO RESET MENU.



Go To Reset Menu

Overview

The Portals™ Service Menu System provides five (5) functions to reset **Coin & Game Audits, High Scores, Credits** or to reset **ALL AUDITS, ADJUSTMENTS & INSTALLS** back to the **Factory Default Settings**.



Important: The **Coin Door** must be **OPEN** allowing the **Memory Protect Switch** to be disabled, so any **Reset** changes can be made.



EXPLANATION & USAGE OF COMMON LARGE ICONS USED IN THIS MENU:



These **non-selectable** icons appear in the selected Menu only when there are **MORE** icons to the **LEFT** or to the **RIGHT** available for selection.



Select and activate to return to the **PREVIOUS** Menu.



Select and activate to **QUIT**, exits & returns to the **Attract Mode**.



Select and activate to view **HELP** Screens of the current Menu*.

⚠ WARNING: ⚠

As soon as any **Reset Icon** is selected & activated, the information associated with the **Reset Icon**, is lost!

* **Help Note:** An explanation of each icon at that menu level will cycle continuously. To exit a display where no icons are available for selection, pressing any button will exit the display.



GO TO RESET MENU

After entering **Portals™**, the **MAIN MENU** now appears. Select the **"RESET"** icon in the **MAIN MENU** with either the **Red "LEFT"** or **Green "RIGHT"** Buttons (the **Flipper Buttons** operates in the same manner) and press the **Black "ENTER"** Button (the **Start Button** operates in the same manner). The **RESET MENU** appears. Continue below for the explanation & usage of the **Icons** in the **RESET MENU**.



Reset Coin Audits

To initiate, from the **RESET MENU**, select the **"COIN"** icon with either the **Red** or **Green Buttons** and press the **Black Button**. ⚠ **ONLY** the **Coin Audits (05-13)** will be reset to zero (0), **Factory Default Settings**. **"REQUEST INSTALLED"** is indicated and returns to the **RESET MENU** with the **"COIN"** icon flashing.



Reset Game Audits

To initiate, from the **RESET MENU**, select the **"AUD"** icon with either the **Red** or **Green Buttons** and press the **Black Button**. ⚠ **ONLY** the **Game Audits (01-04)** & **Standard Audits (01-67)** will be reset to zero (0), **Factory Default Settings**. **Note:** **Coin Audits (05-13)** & **Software Meter Audit (14)** will not be reset. **"REQUEST INSTALLED"** is indicated and returns to the **RESET MENU** with the **"AUD"** icon flashing.



Reset High Scores

To initiate, from the **RESET MENU**, select the **"HSTD"** icon with either the **Red** or **Green Buttons** and press the **Black Button**. ⚠ **ONLY** the **High Scores** will be reset to the current values. **Note:** If these five (5) adjustments were not personally changed by you, the **Factory Default Settings** will be used (see **Section 3, Chapter 4, GO TO ADJUSTMENTS MENU, Standard Adjustments 18-22**). **"REQUEST INSTALLED"** is indicated and returns to the **RESET MENU** with the **"HSTD"** icon flashing.



Reset Credits

To initiate, from the **RESET MENU**, select the **"CRED"** icon with either the **Red** or **Green Buttons** and press the **Black Button**. ⚠ All **Credits** will be reset to zero (0), **Factory Default Settings**. **"REQUEST INSTALLED"** is indicated and returns to the **RESET MENU** with the **"CRED"** icon flashing.



Factory Reset

To initiate, from the **RESET MENU**, select the **"FACT"** icon with either the **Red** or **Green Buttons** and press the **Black Button**. ⚠ All **Audits (except for Audit 14, Software Meter)**, all **Adjustments** and **Installs** will be reset to the **Factory Default Settings**. **Note:** To **RESET ONLY** the **ADJUSTMENTS & INSTALLS** (leaving all the Audits alone), see **Section 3, Chapter 5, GO TO INSTALLS MENU, Install Factory**. **"REQUEST INSTALLED"** is indicated and the **Service Menu** is exited, returning to the **Attract Mode**.

Sec. 3: Go To Reset



Example:

After entering **Portals™**, the **MAIN MENU** now appears. Use the Red "LEFT" or Green "RIGHT" Buttons to select the "RESET" *Icon* (**GO TO RESET MENU**).

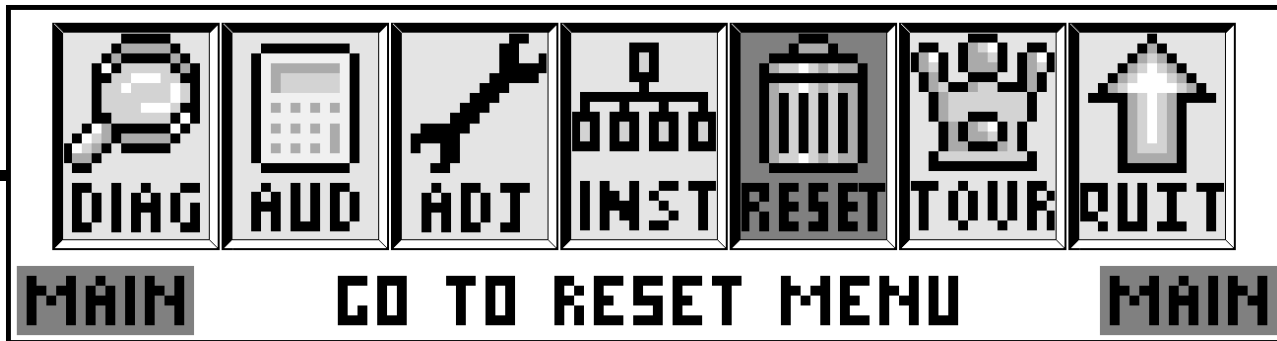

Press the **Black "ENTER" Button** to *activate* this **ICON**. The **RESET MENU** now appears with the "COIN" *Icon* (**RESET COIN AUDITS**) flashing:

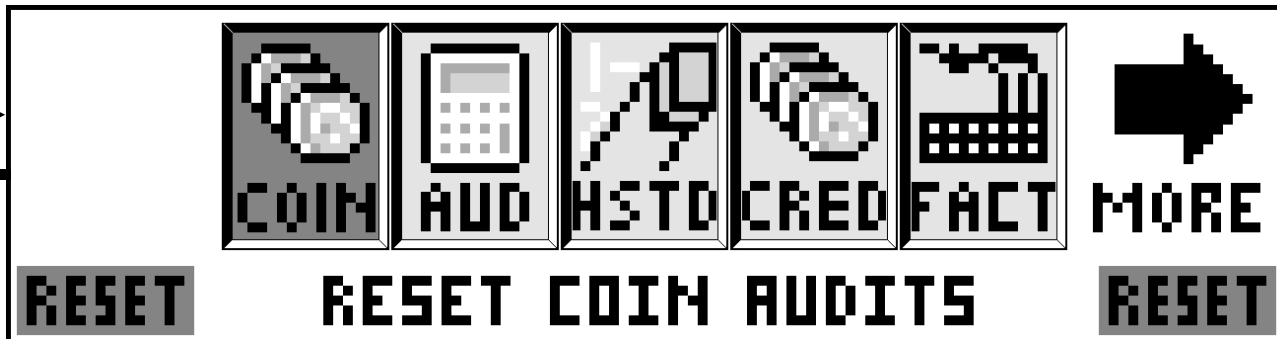

From the **RESET MENU**, select any of the *Icons* ("COIN", "AUD", "HSTD", "CRED") with either the **Red or Green Buttons** and press the **Black Button** to *activate* the **ICON** chosen. After the **ICON** is selected & *activated*, "**REQUEST INSTALLED**" is indicated and is returned to the **RESET MENU** with the previously selected *Icon* flashing.

Important:



AT THIS TIME, **DO NOT** PRESS THE **START BUTTON** OR **BLACK BUTTON** AFTER SELECTING ANY OF THE FIVE (5) **ICONS** UNLESS THIS IS WHAT IS DESIRED. **THE INFORMATION ASSOCIATED WITH THE RESET ICON WILL BE LOST!** PLEASE READ THE PREVIOUS PAGE FOR EXACTLY WHAT WILL HAPPEN IF ANY OF THESE FIVE (5) **ICONS** ARE **SELECTED & ACTIVATED**.



Before performing any **RESET**, write down your **last Audit Totals** (see **Section 3, Chapter 3, GO TO AUDITS MENU**) and any **personalized Adjustment changes** you may have made (see **Section 3, Chapter 4, GO TO ADJUSTMENTS MENU**).

**REQUEST
INSTALLED**

If the "FACT" *Icon* is select and *activated*, "**REQUEST INSTALLED**" is indicated and the **Service Menu** is exited, returning to the **Attract Mode**. See the previous page for explanation & usage of the *Icons* in the **RESET MENU**.

Sec. 3: Go To Reset

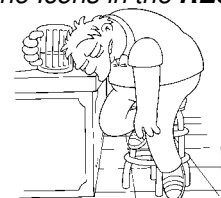



Go To Tournament Menu

Overview

The **Portals™ Service Menu System** provides **6 Steps** necessary to **SET-UP, START, MONITOR** and **END** Pinball Tournaments on your *Tournament Pinball System Ready Pinball Game*. **OPTIONAL EQUIPMENT & HARDWARE (SOLD SEPARATELY) ARE REQUIRED FOR PROPER OPERATION AND USE OF THIS MENU.**

Game code may get upgraded during production; compare all Tournament Adjustments & Audits in the display with the manual and make any corrections to the Tournament Adjustments and/or Audits Tables (*next page*), as necessary. Tournament Adjustments & Audits are subject to change (*with or without notice*). To view Tournament Adjustments & Audits in the display, enter the **Portals™ Service Menu System**. When any change is made and then the next / previous item is selected (*or the Sub-Menu is exited*), the display will momentarily flash **REQUEST INSTALLED**. For details on **Earnings, Standard & Feature Audits**, see Section 3, Chapter 3, **GO TO AUDITS MENU**. For details on **Standard & Feature Adjustments**, see Section 3, Chapter 4, **GO TO ADJUSTMENTS MENU**.

For more details on the equipment & hardware required, Installation and Set-up, read the **ToPS™ Tournament Pinball System Kit Installation Manual** (SPI Part Number: 780-6011-00) provided in the **Optional Tournament Kit** (SPI Part Number: 502-5011-00), not included with this *ToPS™ Ready Pinball Game*.

The equipment & hardware consists of: **BETAbrite™ Electronic 7 X 80 Multi-Color Dot Display** (secured above the Backbox), **Tournament Serial Interface (TSI) Board** (secured in the Backbox), **Tournament Button + Lamp** (secured onto the Front Molding) and all necessary wiring, hardware and documentation (*which also provides suggestions and Tips for ToPS™*).

To order, contact your local Distributor (*view Pages DR. 8 & 9 in the Find-It-In-Front: Dr. Pinball*). You can also call Technical Support or visit our website (*details on the back cover of this manual*).



Important: The **Coin Door** must be **OPEN** allowing the **Memory Protect Switch** to be disabled, so any **Tournament changes** can be made.



EXPLANATION & USAGE OF COMMON LARGE & MINI-ICONS USED IN VARIOUS MENUS & SUB-MENUS:



These **non-selectable** icons appear in the selected Menu only when there are **MORE** icons to the **LEFT** or to the **RIGHT** available for selection.



Select and activate to return to the **PREVIOUS** Menu.



Select and activate to **QUIT**, exits & returns to the **Attract Mode**.



Select and activate to view **HELP** Screens of the current Menu*.



Select and activate to: Move **LEFT** or **RIGHT**, select previous / next or move backwards / forwards.



DECREMENT (-) or **INCREMENT (+)** displayed value or select previous / next.

* **Help Note:** An explanation of each **Mini-Icon** at that menu level will cycle continuously. To exit a display where no **Mini-Icons** are available for selection, pressing any button will exit the display.



GO TO TOURNAMENT MENU (OPTIONAL USE ONLY)

After entering **Portals™**, the **MAIN MENU** now appears. Select the **"TOUR"** icon in the **MAIN MENU** with either the **Red "LEFT"** or **Green "RIGHT"** Buttons (the **Flipper Buttons** operates in the same manner) and press the **Black "ENTER"** Button (the **Start Button** operates in the same manner). The **TOURNAMENT MENU** appears. Continue through this chapter for the explanation & usage of the **Icons** in the **TOURNAMENT MENU**.



Tournament Adjustment & Audit Tables on the next page.

Go To
Tournament Menu



Sec. 3: Tournament ...





TOURNAMENT ADJUSTMENT TABLES

TOURNAMENT ADJUSTMENTS 01-10

Nr.	ADJUSTMENT NAME	USA DEFAULT	YOUR SETTING
01	CREDITS PER PLAY	02	
02	JACKPOT BASE	\$20.00	
03	JACKPOT INCREMENT	\$00.50	
04	JACKPOT MAX.	\$2,500.00	
05	CURRENT DATE/TIME	JANUARY...	

Nr.	ADJUSTMENT NAME	USA DEFAULT	YOUR SETTING
06	START DATE	JANUARY 1	
07	END DATE	FEBRUARY 1	
08	# OF PRIZES	03	
09	AWARD TYPE	CASH	
10	SHOW PLAYER'S CASH	YES	

Note: The above adjustments must be set just before selecting and activating the "START" icon (START TOURNAMENT). See the following pages for explanation and more details.



SIGN MESSAGES A-B (ADJUSTMENTS 11-12)

Nr.	ADJUSTMENT NAME	USA DEFAULT	YOUR SETTING
11	LOCATION MESSAGE	ON	

Nr.	ADJUSTMENT NAME	USA DEFAULT	YOUR SETTING
12	PRIZE MESSAGE	ON	

Sec. 3: Tournament ...



STARTING METER Reading :

STARTING METER Date (MM/DD/YR) :

AUDITOR'S NAME :

CURRENT VOLUME SETTING:

CURRENT METER Reading :

AUDIT Date (MM/DD/YR) :

CPU Version :

DISPLAY Version :

GAME LOCATION NAME :

See Adj. 06 & 07 above >>

TOURNAMENT START DATE :

TOURNAMENT END DATE :

TOURNAMENT AUDIT TABLE



TOURNAMENT AUDITS 01-12

Audit definitions follow in this Chapter.

01	TOTAL PLAYS
02	TOURNAMENT PLAYS
03	TOTAL GAME EARNINGS
04	TOTAL TOUR. EARNINGS
05	JACKPOT

06	NET EARNINGS
07	ACCUM. TOTAL PLAYS
08	ACCUM. TOUR. PLAYS
09	ACCUM. EARNINGS
10	ACCUM. TOUR EARNINGS

11	ACCUM. JACKPOT
12	# TOURNAMENTS





Tournament Adjustments (01-10)

To initiate, from the **TOURNAMENT MENU**, select the "SET UP" *Icon* with either the **Red "LEFT"** or **Green "RIGHT" Buttons** and press the **Black "ENTER" Button**. Select and *activate* either of the ">>" *Mini-Icons* to view the next or previous Tournament Adjustment in this group. Select and *activate* either of the "-" or "+" *Mini-Icons* to change the setting, if desired (*the Default Setting is noted in the definitions below*). The display will describe the **Tournament Adjustment Number**, **Tournament Adjustment Name** and the **Current Tournament Adjustment Setting**. The current Tournament Adjustment will remain in the display until the next Tournament Adjustment is viewed or when this Menu is exited.

IMPORTANT FOR TOURNAMENT USERS: *Select the settings carefully. For Tips for ToPS™ (different Tournament Sample Set-Ups, etc.), view the ToPS™ Tournament Pinball System Kit Installation Manual (SPI Part Number: 780-6011-00) provided in the Optional Tournament Kit (SPI Part Number: 502-5011-00). Before allowing players to begin after you've started a Tournament, double-check the Normal Mono-Color Dot Display and Top Multi-Color Dot (Beta Brite®) Display to ensure everything you want is displayed correctly. Once a Tournament is started, no adjustments can be made until you end the Tournament (by selecting the "END" Icon). Allowing players to qualify, then ending a Tournament prematurely to make corrections will affect the outcome of the Tournament. View the ToPS™ Manual for more details.*

WARNING: Changes made in any Adjustments will be lost after a FACTORY RESET or removal of the CPU/Sound Board Batteries.

Nr.	TOURNAMENT ADJUSTMENT NAME: Definition
01	CREDITS PER PLAY: Set between 01 - 10 . Default is 02 . Set the maximum number of <i>Credits</i> that may be accumulated per game.
02	JACKPOT BASE: Set between \$00.00 - \$999,999.00 (<i>increments of \$1</i>). Default is \$20.00 . Set the initial <i>Prize Pool Amount</i> to be offered for the Tournament. Note: <i>The displays will present the words "PRIZE POOL" in lieu of the word "JACKPOT".</i>
03	JACKPOT INCREMENT: Set between \$00.00 - \$999,999.99 (<i>increments of 1¢</i>). Default is \$00.50 . Set the <i>Prize Pool Increment</i> which will increase the <i>Prize Pool Amount</i> with each Tournament Game played.
04	JACKPOT MAX.: Set between \$00.00 - \$999,999.00 (<i>increments of \$1</i>). Default is \$2,500.00 . Set the maximum cap to be placed on the <i>Prize Pool</i> during a Tournament. Note: <i>The displays will present the words "PRIZE POOL" in lieu of "JACKPOT".</i>
05	CURRENT DATE/TIME: Set the current date and time. After setting the Start and End Dates in Tournament Adjustments 6 & 7, the Tournament will then start automatically*. <i>*Requires the TIMEKEEPER™ IC (included in the kit) installed in Location U212 on the CPU/Sound Board.</i>
06	START DATE: Set between JANUARY through DECEMBER . Default is JANUARY . After the month desired is set, a valid day must be set. To Start a Tournament , go back to the TOURNAMENT MENU and select the "STRT" <i>Icon</i> (<i>see the next page</i>).
07	END DATE: Set between JANUARY through DECEMBER . Default is FEBRUARY . After the month desired is set, a valid day must be set. To End a Tournament , go back to the TOURNAMENT MENU and select the "END" <i>Icon</i> (<i>see the next page</i>).
08	# OF PRIZES: Set between 01 - 05 . Default is 03 . Set the maximum number of <i>Prize Positions</i> to be awarded during a Tournament. Selections (<i>cannot be changed</i>) are as follows: Set to 01 , the Tournament Winner is awarded 100% of the Prize Pool. Set to 02 , the 1st & 2nd place winners are awarded 70% / 30% , respectively. Set to 03 , the 1st, 2nd & 3rd place winners are awarded 50% / 30% / 20% , respectively. Set to 04 , the 1st, 2nd, 3rd & 4th place winners are awarded 50% / 25% / 15% / 10% , respectively. Set to 05 , the 1st, 2nd, 3rd, 4th & 5th place winners are awarded 50% / 20% / 15% / 10% / 5% , respectively.
09	AWARD TYPE: Set to CASH, POINTS, TICKET, NONE or PRIZE . Default is CASH . <i>This adjustment determines how the Prize Pool is to be represented in the Attract Mode on both the Normal and top Beta-Brite® Displays.</i> Select CASH for the displays to represent the Prize Pool amount (<i>based on Jackpot Base and Max.</i>) in \$Dollars . Select POINTS for the displays to represent the Prize Pool amount in Points . Select TICKET for the display to represent the Prize Pool amount in Tickets . Select NONE NOT TO represent the Prize Pool amount (<i>if prize(s) to be awarded are not Cash, Points or Tickets</i>). Select PRIZE , if applicable.
10	SHOW PLAYER'S CASH: Set to YES or NO . Default is YES . When set to YES , both the Beta-Brite® Multi-Color Dot Display and the Normal Mono-Color Display exhibit the Cash amount in the Attract Mode .

Sec. 3: Tournament ...

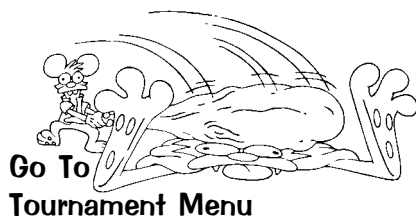



Start Tournament (select only after Set-Up is completed)

To initiate, from the **TOURNAMENT MENU**, select the "STRT" *Icon* with either the Red "LEFT" or Green "RIGHT" **Buttons** and press the Black "ENTER" **Button**. The "START TOURNAMENT?" MENU appears with the "NO" *Mini-Icon* flashing.

If **Set-Up (Tournament Adjustments)** was not completed **OR** the **Tournament Audits were not recorded from the prior Tournament**, exit this Menu by activating the "NO" *Mini-Icon*. If **Set-Up** was completed and the **Tournament Audits** were recorded, select and activate the "YES" *Mini-Icon*.

The Pinball Game is set to **Tournament Ready Mode**

(the **Flashing Tournament Button** must be depressed for a **Tournament Game** after the proper credit is inserted). "REQUEST INSTALLED" is indicated and returns to the **TOURNAMENT MENU** with the "STRT" *Icon* flashing. **Note:** If the "STRT" *Icon* appears to be non-functioning, it is because a **Tournament** is in progress. The **Tournament** must first be stopped (select and activate the "END" *Icon* in the **TOURNAMENT MENU**).



Stop Tournament (select only after a Tournament is started)

To initiate, from the **TOURNAMENT MENU**, select the "END" *Icon* with either the Red "LEFT" or Green "RIGHT" **Buttons** and press the Black "ENTER" **Button**. The "END TOURNAMENT?" MENU appears with the "NO" *Mini-Icon* flashing. If the

Tournament was not completed, exit this Menu by activating the "NO" *Mini-Icon*. If the **Tournament** was completed (the **End Date** set has passed), select and activate the "YES" *Mini-Icon*. The Pinball Game is taken out of **Tournament Ready Mode** (to readjust any **Tournament Adjustments**, the **Tournament** must be "stopped"). "REQUEST INSTALLED" is indicated and returns to the **TOURNAMENT MENU** with the "END" *Icon* flashing.

Record your Tournament Audits at this time as they will be reset (except for the "Accumulative Audits") if another Tournament is started!



Sec. 3: Tournament ...



Tournament Prizes

To initiate, from the **TOURNAMENT MENU**, select the "PRIZ" *Icon* with either the Red "LEFT" or Green "RIGHT" **Buttons** and press the Black "ENTER" **Button**. Select and *activate* either of the ">>" *Mini-Icons* to view the next or previous Leader in this group. The display will describe the **Leader Placement (1st, 2nd, 3rd, 4th & 5th), Leader Name, 4-Digit Pin-Code,** and **Prize Pool** portion for the **Current and Previous Tournaments**. The current Leader (*and related information*) will remain in the display until the next Leader is chosen or when the Sub-Menu is exited.



Tournament Audits (01-12)

To initiate, from the **TOURNAMENT MENU**, select the "AUD" *Icon* with either the Red "LEFT" or Green "RIGHT" **Buttons** and press the Black "ENTER" **Button**. Select and *activate* either of the ">>" *Mini-Icons* to view the next or previous **Tournament Audit** in this group. The display will describe the **Tournament Audit Number, Tournament Audit Name** and the **Current Tournament Audit Total (Value)**. The current **Tournament Audit** will remain in the display until the next **Tournament Audit** is viewed or when this Menu is exited.

IMPORTANT FOR TOURNAMENT USERS: >>>> **A L L** of the **Tournament Audits 01-12** are **RESET O N L Y** if a **Factory Reset is done** (see **Section 3, Chapter 6, GO TO RESET MENU**). >>>> **Tournament Audits 01-06** are **RESET ONLY** if a **new Tournament is started**. >>>> **Tournament Audits 07-12** are **NOT RESET***, they're **accumulative (totals accumulate since the first Tournament was played)**. *if no **Factory Reset is done**.

Nr.	TOURNAMENT AUDIT NAME: Definition
01	TOTAL PLAYS: Provides the total number of <i>Regular and Tournament Games</i> played while a <i>Tournament is active (in progress)</i> . This total is derived by adding Tournament Audit 02, TOURNAMENT PLAYS , with Regular Plays .
02	TOURNAMENT PLAYS: Provides the total number of <i>Tournament Games</i> played while a <i>Tournament is active (in progress)</i> .
03	TOTAL GAME EARNINGS: Provides the total <i>Gross Earnings accepted</i> , while a <i>Tournament is active (in progress)</i> .
04	TOTAL TOUR. EARNINGS: Provides the total <i>Tournament Earnings (Audit 03 less Regular Game Earnings)</i> while a <i>Tournament is active (in progress)</i> .
05	JACKPOT (PRIZE POOL TOTAL): Provides the total <i>Prize Pool (Jackpot) Amount</i> to be paid out while a <i>Tournament is active (in progress)</i> .
06	NET EARNINGS: Provides the total <i>Net Earnings (Gross Earnings less Prize Pool)</i> while a <i>Tournament is active (in progress)</i> .

Tournament Audits 07-12 continued on the next page.





The following Tournament Audits **WILL NOT BE RESET** if a new Tournament is started. **ALL AUDITS** can be reset if a Factory Reset is done!

- 07 **ACCUM. TOTAL PLAYS:** Provides the accumulative total amount of *Regular & Tournament Games* played since the first Tournament was played.
- 08 **ACCUM. TOUR. PLAYS:** Provides the accumulative total amount of *Tournament Games* played since the first Tournament was played.
- 09 **ACCUM. EARNINGS:** Provides the total Gross Earnings *accepted*, since the first Tournament was played.
- 10 **ACCUM. TOUR EARNINGS:** Provides the accumulative total Tournament Game Earnings since the first Tournament was played.
- 11 **ACCUM. JACKPOT:** Provides the accumulative total of Prize Pool (*Jackpot*) Amounts paid out since the first Tournament was played.
- 12 **# TOURNAMENTS:** Provides the number of Tournaments (*not individual Tournament Games*) since the first Tournament was played.



Sign Messages A-B (Tournie Adj. 11-12)

To initiate, from the **TOURNAMENT MENU**, select the "A-B TEXT" *Icon* with either the **Red "LEFT"** or **Green "RIGHT"** Buttons and press the **Black "ENTER" Button**. Select and *activate* either of the ">>" *Mini-Icons* to view the next or previous Tournament Adjustment in this group. Select and *activate* either of the "-" or "+" *Mini-Icons* to change the setting, if desired (*the Default Setting is noted in the definitions below*). The display will describe the **Tournament Adjustment Number**, **Tournament Adjustment Name** and the **Current Tournament Adjustment Setting**. The current Tournament Adjustment will remain in the display until the next Tournament Adjustment is viewed or when this Menu is exited.

Nr. **TOURNAMENT ADJUSTMENT NAME: Definition**

- 11 **LOCATION MESSAGE:** Set to **ON, CHANGE** or **OFF**. Default is **ON**.
When set to **CHANGE**, a new message can be set or the old one can be edited (*select the "+" Mini-Icon to change settings until "CHANGE" appears in the display, then select the ">>" Mini-Icon to access.*). At the top left corner of the Display, the letter **A** is indicated (*blinking*) in the first available position. Vary the letter(s) by operating the Left and Right Flipper Buttons (*or "RED" or "GREEN" Buttons*). With the desired letter indicated, depress the **Start Button** to lock in the letter and advance to the next character. Repeat this procedure until the desired message is completed in the display. Select the "<" or ">" characters to back-space (*erase*) and/or to move forward in an already typed message. After completion, press the **"BLACK" Button**, "REQUEST INSTALLED" is indicated and then exits this sub-menu.
- 12 **PRIZE MESSAGE:** Set to **ON, CHANGE** or **OFF**. Default is **ON**.
Procedure identical to Tournament Adjustment 11, Location Message.

The **DEFAULT LOCATION MESSAGE** is:

STERN PINBALL PROUDLY PRESENTS...

The **DEFAULT PRIZE MESSAGE** is:

YOU CAN BE THE NEXT BIG WINNER!



IMPORTANT FOR TOURNAMENT USERS: 2 additional messages can be added by using the **Beta Brite® Remote**. More details in the **ToPS™ Tournament Pinball System Kit Installation Manual** (SPI Part Number: 780-6011-00) provided in the **Optional Tournament Kit** (SPI Part Number: 502-5011-00).

HOW TO ENTER A MESSAGE:
 1. POINT THIS REMOTE CONTROL (UPBOARD) AT THE DISPLAY.
 2. PRESS THE [PROGRAM] KEY. THE WORDS "PROG TEXT" WILL APPEAR ON THE DISPLAY.
 3. ENTER THE MESSAGE YOU WANT TO BE DISPLAYED. (USE THE [L] AND [SELECT] KEYS FOR PUNCTUATION).
 4. PRESS THE [RUN] KEY TWICE.
 SEE YOUR PROGRAMMING MANUAL FOR ADDITIONAL INSTRUCTIONS AND DISPLAY FEATURES.

BETA Brite

Go To
Tournament Menu



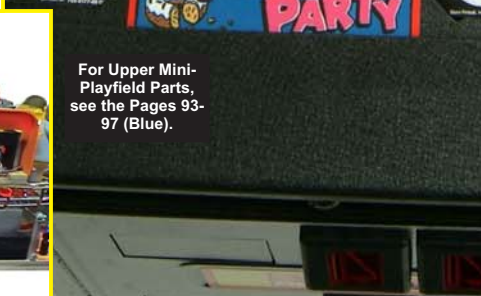

Sec. 4: Parts Id. ...

For Upper Mini-Playfield Parts, see the Pages 93-97 (Blue).

Parts Identification & Location (The Pink Pages)

Overview

This section provides the Part N^os and locations of all the components in this Pinball Machine. The parts are arranged in three groups: **BACKBOX**, **CABINET** and **MAIN PLAYFIELD**. Generic parts which may change as production continues (quantity and/or size) are listed together. Quantities greater than 0 indicates that the part is used in this game. Since quantity changes may occur, an item indicating "0" may be used. Compare the item which needs to be replaced with the drawings provided (*the Posts, Sockets, Bulbs & Rubber Rings are drawn actual size*). Major Assemblies (including the 2nd Level Playfield) & Ramps are detailed in the *Blue Pages*, Pages 75-98.

Important: Read all "Take Note:" items.

For 2nd Level (Upper) Playfield, see the Blue Pages (94-97)



Pinball Rejuvenation Kit Available
502-5013-77
This kit consists of 8 oz. Novus Wax #2 Fine (Red) (675-0003-01), cloth and all Rubber Rings & Bulbs used in this Pinball Machine.



Section 4, Table of Contents

Chapter 1: The Pink Pages

Overview..... 59

BACKBOX:

The Simpsons™ Pinball Party Backbox Assy. 60
Speaker Panel Assy. for the Backbox & Assoc. Parts: ... 61

CABINET:

Cabinet -General Parts & Switches 62-63

PLAYFIELD:

Main Playfield - General Parts, Metal Rails/Ball Guides & Switches (Above) 64-65
Main Playfield - General Parts & Switches (Below) 66
Main Playfield & Mini-Playfield Plastics (Screened & Clear) & Decals 67
Main Playfield - Rubber Parts Red and Black 68
Main Playfield & Mini-Playfield - Metal Posts (Screws) and Nuts 69
Main Playfield & Mini-Playfield - Hex Spacers 70
Main Playfield & Mini-Playfield - Posts and Spacers 71
Main Playfield & Mini-Playfield - Small Bayonet Type Bulbs & Sockets 72
Main Playfield & Mini-Playfield - Large Bayonet Type Bulb and Sockets 73
Main Playfield & Mini-Playfield - Wedge Base Bulbs and Sockets 74

Chapter 2: The Blue Pages

Overview..... 75
Drawings for Major Assemblies & Ramps (includes the 2nd Level Mini-Playfield) 76-98

Sec. 4: Parts Id. ...

Not sold as an assembly, order the individual part(s) actually required.



PINBALL PARTY Backbox Assembly, 505-6002-77-77 (Items 1-27)

‡ Item 20, Button Hole Plug (Black) is the optional ToPS™ Access Hole; if removing for the Optional ToPS™ Kit, save with the game.

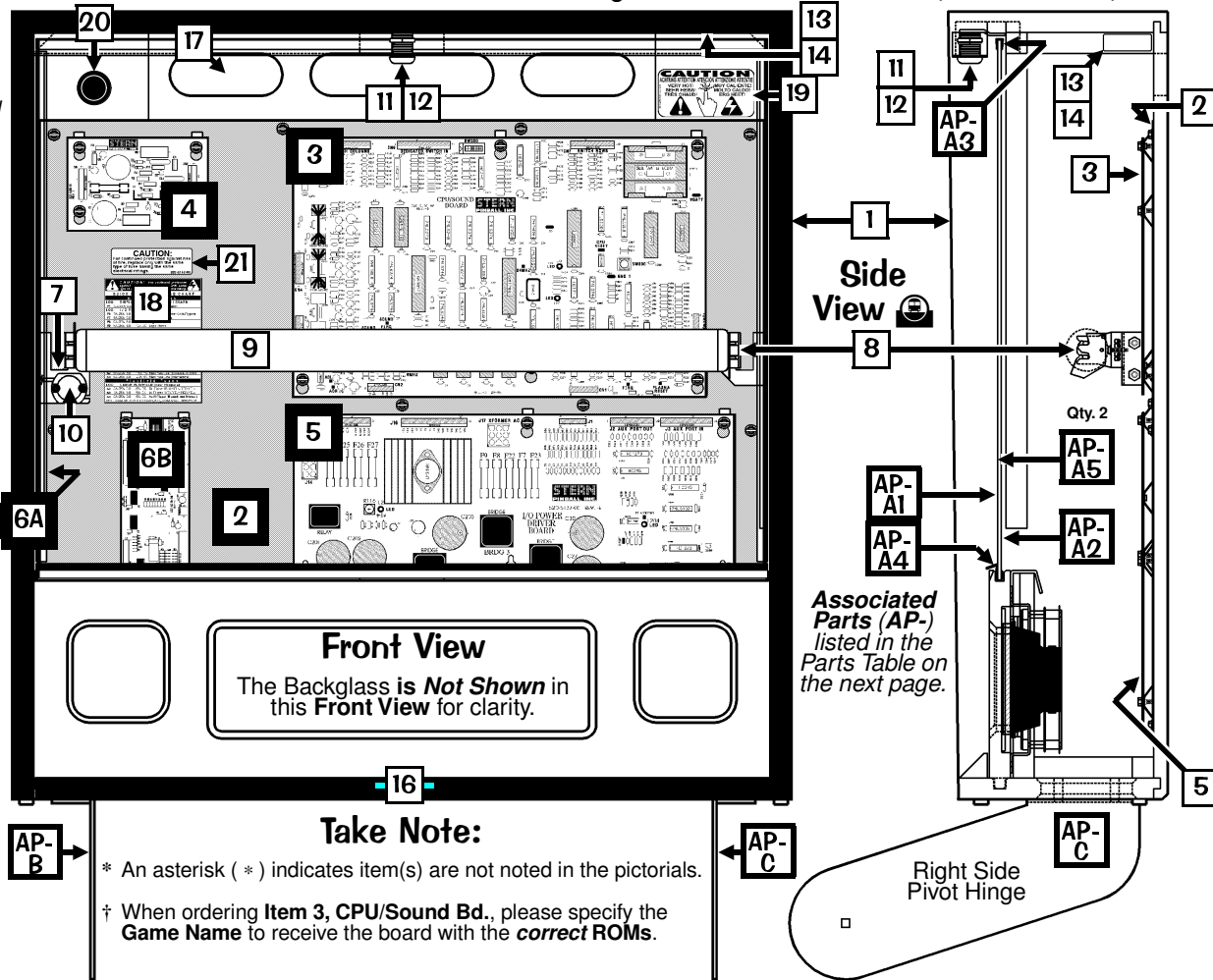

Front View
The Backglass is **Not Shown** in this Front View for clarity.

Associated Parts (AP-) listed in the Parts Table on the next page.

Take Note:

- * An asterisk (*) indicates item(s) are not noted in the pictorials.
- † When ordering Item 3, CPU/Sound Bd., please specify the Game Name to receive the board with the correct ROMs.

Sec. 4: Parts Id. ...

Nº	BACKBOX PART NAME	QTY.	SPI PART Nº	Nº	BACKBOX PART NAME	QTY.	SPI PART Nº
1	Backbox SPP Screened No Parts	1	525-5631-00-77	13	Ballast Mounting Plate	1	535-8657-00
<i>Item 1 Note: Black Textured T-Molding is installed and cannot be ordered separately.</i>							
2	PCB Metal Mounting Plate	1	535-5809-14	14	Ballast CU45Z-W 1/2" Core 120v 60 Hz 13W	1	010-5015-00
<i>Item 2 is secured to Item 1 by: #8 X 1/2" HWH AB (Zinc) (Qty. 13) (234-5101-00) and #10 Washer 7/32" I.D. X .5" O.D. X 1/16" Thick (Qty. 4) (242-5003-00)</i>							
3	† CPU/Snd. Bd. w/ATMEL Sound Processor	1	520-5300-00	<i>Ballast, EU / UK Only 5/8" Core 50/60 Hz 010-5015-01</i>			
4	Display Power Supply Board	1	520-5138-00	<i>Items 13 & 14 are secured to Item 1 by: #6 X 5/8" HWH AB (Zinc) (Qty. 2) (234-5102-04)</i>			
5	I/O Power Driver Board	1	520-5137-01	15*	#1 Roto Lock Male (on Cabinet)	1	355-5006-01
<i>Items 3, 4 & 5 are secured to Item 2 by: #8-32 X 3/8" HWH MS (Qty. 19) (237-5903-00)</i>							
6A	3X Trans. Drvr. Bd. (UK/Special Apps.Only)	1	520-5068-01	16	#1 Roto Lock Female (R2-0002-02)	1	355-5006-02
6B	Tournament Serial Interface (TSI) Bd. ToPS™	1	520-5220-00	<i>Item 16 is secured by: #10-24 X 1-3/4" CBSN (Qty. 2) (231-5022-00), #10-24 Keps Nut (Qty. 2) (240-5207-00) and #10 Washer 7/32" ID X .5" OD X 1/16" (Qty. 2) (242-5003-00)</i>			
<i>Item 6A is required for UK Games to support Auxiliary assemblies listed under the Coil Matrix of Q1-Q32; also used for Special Applications such as Ticket / Coin Dispensers used in conjunction with Item 6B ToPS™ Tournament Serial Board.</i>							
7	Fluorescent Light Bracket Assy. Left	1	515-6545-00	17	Back Vent Grill 2-1/2" X 18"	1	545-5072-02
<i>For Individual Items use : Fluorescent Light Bracket Left (535-7739-00), Lamp Holder** (Self-Locking) (077-5214-00) and Starter Base (with Leads)*** (077-5213-00).</i>							
8	Fluorescent Light Bracket Assy. Right	1	515-6545-01	18	Fuse Description Decal (Generic)	1	820-6152-01
<i>For Individual Items use : Fluorescent Light Bracket Right (535-7739-01), Lamp Holder** (Self-Locking) (077-5214-00) and Starter Base (with Leads)*** (077-5213-00).</i>							
<i>** secured by: #6-32 X 5/8" PPH MS (Sems) Zinc (Qty. 1) (232-5203-00)</i>							
<i>*** secured by: #4-40 X 1/2" PPH MS (Sems) Zinc (Qty. 2) (237-5813-00)</i>							
<i>Items 7 & 8 are secured to Item 1 by: #10-24 X 1-1/4" Carriage Bolt Sq. Neck (Qty. 2/per) (231-5012-00), #10-24 Keps Nut (Qty. 2/per) (240-5207-00) and 3/4" X 3" Reinforced Strapping Tape (Qty. 1, Sold in 12" Lengths only) (626-5040-00)</i>							
9	Fluorescent Tube 24" (F18T8CW)	1	165-5061-00	19	"CAUTION - VERY HOT" Decal	1	820-6266-00
10	Starter - Fluorescent (FS2 Light)	1	165-5011-01	20‡	Button Hole Plug (Blk) (Happ #52-6214-00)	1	500-6566-00
11	Lock Mounting Plate	1	535-8128-01	21	Fuse Label (UL)	1	820-6143-00
12	Lock 5/8" Barrel, 3/4"ø, 1.5" Flat Cam	1	355-5055-00	22*	Backbox Date Label	1	820-5091-00
<i>Items 11-12 are secured by: #8 X 5/8" TP Torx T20 (Qty. 4) (237-5947-00)</i>							
				23*	Ribbon Cable, 20-Pin (4")	1	036-5000-04
<i>Item 23 (20-Pin) connects the CPU/Sound Board to the I/O Power Driver Board.</i>							
				24*	Ribbon Cable, 26-Pin (40")	1	036-5001-40
<i>Item 24 (26-Pin) connects the CPU/Sound Board to the Display Controller Board.</i>							
				25*	1/4" Clamp (Double)	2	040-5000-23
				26*	1/2", 3/4" & 1" Clamp (Single)	9	040-5000-XX
<i>Items 25-26 are secured to Item 1 by: #8 X 1/2" HWH AB (Zinc) (Qty. 13) (234-5101-00) -XX Note: for 1/2" use -06 (Qty. 1); for 3/4" use -08 (Qty. 2); for 1" use -09 (Qty. 6)</i>							
				27*	Ground Strap (5") (by Item 12)	1	600-5006-05



Not sold as an assembly, order the individual part(s) actually required.



PINBALL PARTY Speaker Panel Assy. for the Backbox, 515-6888-03 (Items 1-15) and Assoc. Parts: Backglass Assembly & Pivot Hinges (Left & Right) (Items AP-A - AP-C)

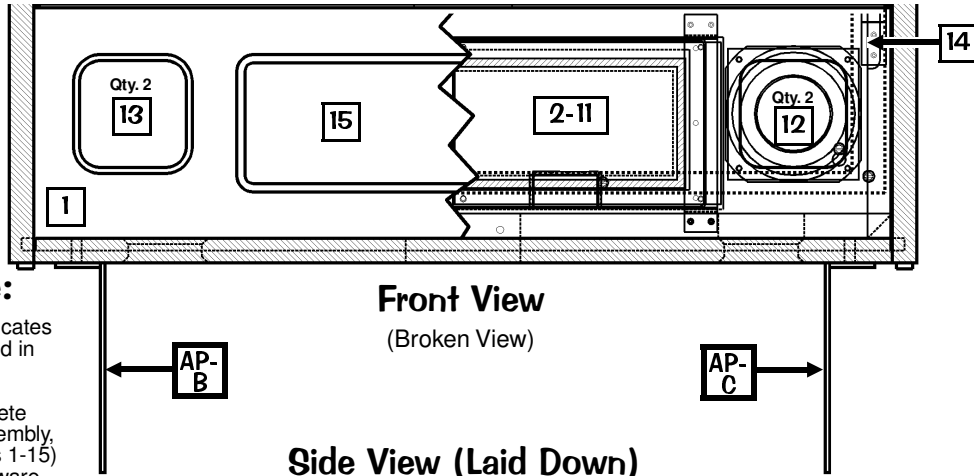

Take Note:

* An asterisk (*) indicates item(s) are not noted in the pictorials.

1. Ordering the complete Speaker Panel Assembly, 515-6888-03 (Items 1-15) will include all hardware.

For clarity, the below drawing **does not show** the speaker(s).

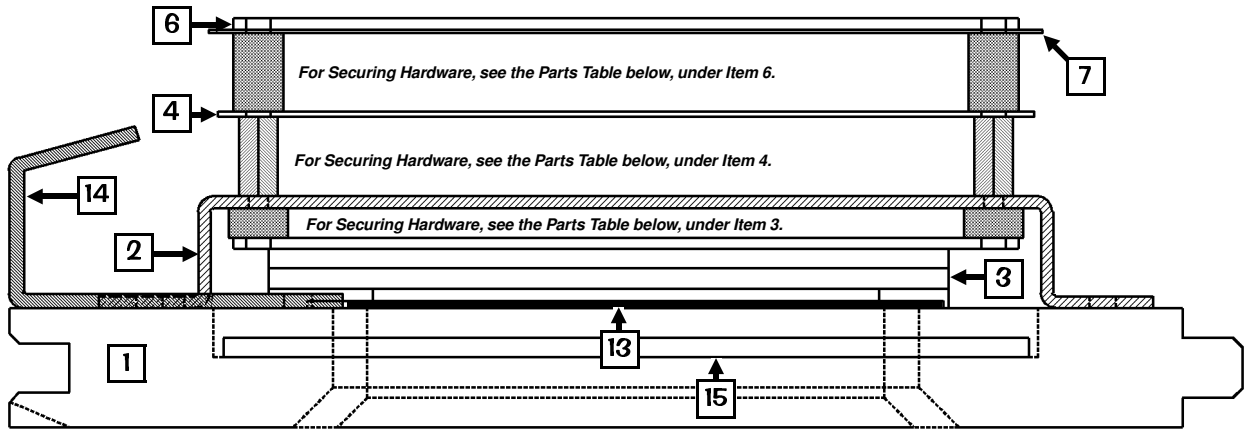

Nº	SPEAKER PANEL PART NAME	QTY.	SPI PART Nº
1	Speaker Panel (Black Wood)	1	525-5515-00
2	Dot Matrix Disp. Bd. Mounting Bracket	2	535-8368-01
Item 2 is secured to Item 1 by: #8 X 3/4" HWH AB (Zinc) (Qty. 4/per) (234-5103-00)			
3	Dot Matrix Display Board 128 X 32	1	520-5052-00
Item 3 is secured to Item 2 by (at corners): 3/16" X 3/8" Spacer Gray (Qty. 4) (254-5000-18) and #6-32 X 1/2" HWH Swage (Serr) Zinc (Qty. 4) (237-5976-03)			
Item 3 is secured to Item 4 (at the top center) by: 3/4" X 1/4" Hex Spacer #6-32 Tap (Qty. 1) (254-5008-04) and #6-32 X 1/4" PPH MS (Sems) Zinc (Qty. 1) (232-5200-00)			
4	Static Shield (Steel Plate)	1	535-6437-00
Item 4 is secured to Item 2 by: 1/2" X 1/4" Hex Spacer #6-32 Tap (Qty. 4) (254-5008-03) and #6-32 X 1/2" PPH MS (Sems) Zinc (Qty. 2, on Left Side only) (232-5202-00)			
5*	Edge Protector (on Item 4)	2	545-5592-01
6	Display Controller Board FCC-FEB98	1	520-5055-03
Item 6 is secured to Item 4 by: 1/2" X 5/16" X .144 ID Spacer Tap (Qty. 3) (254-5014-00), #6-32 X 3/4" PPH MS (Sems) Zinc (Qty. 3) (237-5504-00), 1/2" X 1/4" Hex Spacer #6-32 Tap (Qty. 1) (254-5008-03) and #6-32 X 1/4" PPH MS (Sems) Zinc (Qty. 2) (232-5200-00)			
7	RF Shield	1	820-5092-00
Item 7 is secured inbetween: "Item 6" and its' mounting hardware described.			
8*	Ground Strap (25") (on Items 4, 6, 12)	4	600-5006-25
9*	1/2" Clamp (Single) (on Item 4)	1	040-5000-06
10*	Ribbon Cable, 14-Pin	1	036-5260-00
Item 10 Note: The 14-Pin cable connects the Dot Matrix Disp. Bd. to the Disp. Controller Bd.			
11*	Foam 3/16" Thk. X 1/4" X 36"	6	626-5026-00
Above Item 11 is self-adhesive. Located between Items 3 & 17. Sold in 12" Lengths only.			
12	Speaker (Shld.) 4" 8Ω MG Elec #4060SH	2	031-5004-01
13	Speaker Grill (Black w/no Artwork)	2	535-8081-01
14	Speaker Panel Hook Bracket	2	535-7009-02
Items 12, 13 & 14 are secured by: #8 X 3/4" HWH AB (Zinc) (Items 12/13: Qty. 4/per; Item 14: Qty. 2/per) (234-5103-00)			

Nº	INDIVIDUAL PART NAME	QTY.	SPI PART Nº
15	Plastic Shield (Display Cover)	1	545-5884-00
Item 15 is secured to Item 2 by: #6 X 3/8" HWH AB (Zinc) (Qty. 8) (234-5000-00)			

The Associated Parts AP-A thru AP-C are also noted in the Backbox Assembly drawings on the previous page.

ASSOC. PARTS ARE NOT INCLUDED WITH BACKBOX/SPKR. PANEL ASSY'S.

Nº	ASSOC. BACKBOX PART NAME	QTY.	SPI PART Nº
AP-A	Backglass Assembly (Game Nº XX)	1	See Parts Below
ORDER ONLY INDIVIDUAL PART(S) NEEDED:			
AP-A1	Clear Backglass 25.906" X 19.187"	1	660-5038-02
AP-A2	The Simpsons™ P.P. Film Art (#77)	1	830-5277-00
AP-A3	Top Plastic Channel - 26"	1	545-5018-15
AP-A4	Bottom Plastic Lift Channel - 26-1/16"	1	545-5021-01
AP-A5	Plastic Edging (Left/Right) - 18-1/8"	2	545-5018-14
AP-A6*	Tape (double-sided) (12" Length)	1	626-5005-00
Note: AP-A6 secures AP-A3--A5 to AP-A1 (only 6" required)			
AP-B	Pivot Hinge Left	1	535-7999-00
AP-C	Pivot Hinge Right	1	535-7999-01
Items AP-B & AP-C are secured to Backbox by: 1/4"-20 X 1-1/4" C.B. Sq. Neck (Qty. 4) (231-5003-00), 1/4"-20 Flange Nut (Qty. 4) (240-5300-00) and Fend Washer 1/4" I.D. X 1" O.D. (Qty. 1) (242-5009-00)			
Items AP-B & AP-C are secured to Cabinet by: 1/4"-20 X 7/8" Carriage Bolt Sq. Neck (Qty. 2) (231-5014-00), Hinge Spacer (Qty. 2) (530-5099-00), Washer 1/4" I.D. X 7/8" O.D. X 1/8" Yellow (Qty. 1/per) (242-5016-01), Fend Washer 1/4" I.D. X 1" O.D. (Qty. 1/per) (242-5009-00) and 1/4"-20 Flange Nut (Qty. 1/per) (240-5300-00)			
Note: Inside cabinet holes are covered by BLACK MYLAR COVER DISCS (QTY. 2) (820-5041-00) to hide securing hardware (AP-B & AP-C above) from player view.			



Cabinet - General Parts & Switches

For Backbox Parts see the previous two pages.

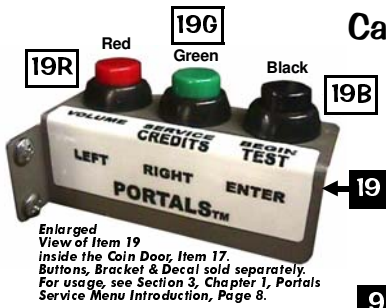

Enlarged View of Item 19 inside the Coin Door, Item 17. Buttons, Bracket & Decal sold separately. For usage, see Section 3, Chapter 1, Portals Service Menu Introduction, Page 8.

Take Note:

Item 11, Button Hole Plug (Blk) is the Optional Tourne Button Access Hole. If removing for the Optional Tournament Button, save with the game.

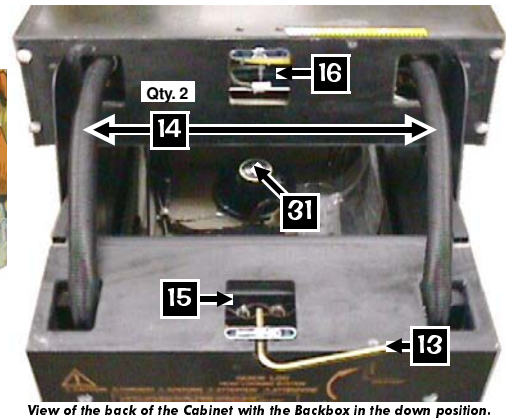

View of the back of the Cabinet with the Backbox in the down position.

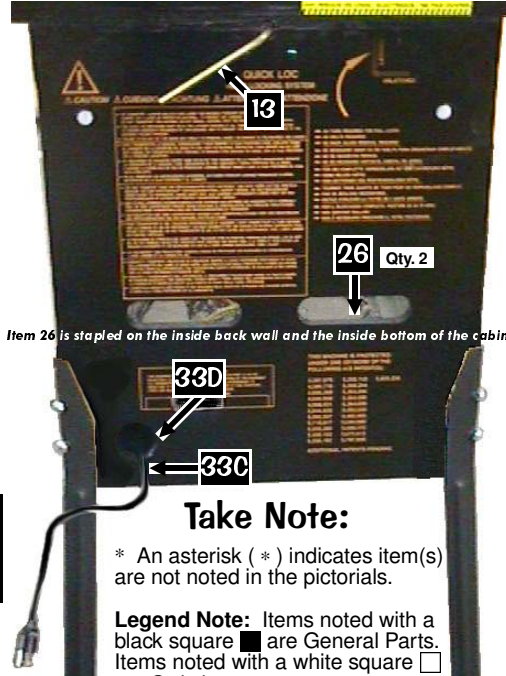

Item 26 is stapled on the inside back wall and the inside bottom of the cabinet.

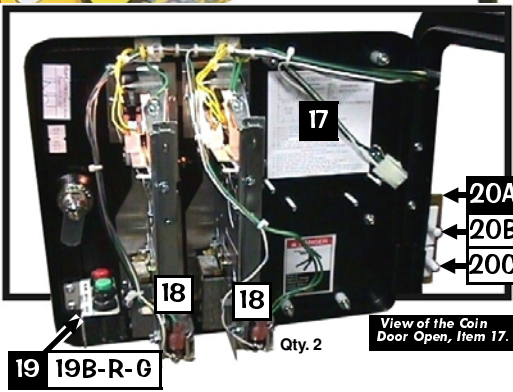

View of the Coin Door Open, Item 17.

Take Note:

* An asterisk (*) indicates item(s) are not noted in the pictorials.

Legend Note: Items noted with a black square are General Parts. Items noted with a white square are Switches.

Sec. 4: Parts Id. ...

Nº	CABINET PART NAME	QTY.	SPI PART Nº	Nº	CABINET PART NAME	QTY.	SPI PART Nº
1	T.S.P.P. Screened Cabinet (No Parts)	1	525-6000-77	13	Hex Key Allen Wrench 5/16"	1	777-0001-00
2	Black Leg & Leveler Assembly	4	500-5921-50	14	Corrugated Tubing Black 1 1/4"ø X 2.6' Lg.	2	605-5008-00
Item 2 is secured by: Leg Bolt Back Plate (535-5703-00) and Leg Bolt 3/8" X 16 X 2-1/2" Hex 5/8" Hd. (2/per) (231-5001-01). To order just a Leg Leveler (3/8" - 16 X 3") use SPI Nº: 500-5017-00. A Leg "without" a Leg Leveler is not available.							
3	Start Button (Red) + Lamp Assembly	1	500-6388-02	15	#1 Roto Lock Male (R2-0055-02)	1	355-5006-01
Item 3 includes the Switch. FOR SWITCH ONLY see Item 25 on the Next Page.							
4*	#555 Wedge Base Bulb (Clear)	1	165-5002-00	16	#1 Roto Lock Female (on Backbox)	1	355-5006-02
Item 4 is included with Item 3, for just a replacement Bulb use the above number.							
5	Ball Shooter (Plunger) Assembly	1	500-6146-00-04	17	Coin Door (with Validator) USA only	1	500-5018-172
Item 5 is secured by: Support Plate (Qty. 1) (535-5027-00), #10-32 X 3/8" SHWH (Serr) Swage (Qty. 3) (237-5985-00) and #6 X 5/8" HWH AB (Zinc) (Qty. 2) (234-5002-00). FOR A BREAKDOWN OF PARTS SEE: Sec. 4, Chp. 2, Drawings for ... Assemblies...							
6	Flipper Button (Red) Assembly	2	500-5026-32	18	Coin Door Switch (USA)	2	180-5024-00
Item 6 is secured by: Pal Nut for Flipper Button (Metal) (Qty. 2) (240-5003-01) and is fitted with: O-Ring 11/32" X 7/32" X 1/16" (Qty. 1/per) (545-5850-00) Item 6 DOES NOT include the Switch. FOR SWITCHES ONLY see Items 23A/B on the Next Page.							
7	Rear Glass Channel 20-3/8" Length	1	545-5038-00	18	FYI: Coin Door Switch (¥ Japan)	0	180-5091-00
8	Plastic Channel 42-5/8" Lg. (Left/Rt.)	2	545-5017-00	19	Bracket for below Portals™ Switches	1	535-6860-03
9	Side Armor "with holes" (Left & Right)	2	535-7297-02	19B	Push-Button Portals™ Switch (Black)	1	180-5192-00
Item 9 is secured by: Pem Stud 1/4 X 1" FH (Qty. 2/per) (237-6116-01), 1/4-20 Flange Nut (Qty. 2/per) (240-5300-00) and #8 X 5/8" T20 Tamper Proof (Qty. 2/per) (237-5947-00)							
10	Front Molding - Black	1	500-5757-02-00	19R	Push-Button Portals™ Switch (Red)	1	180-5192-02
Item 10 requires: Self-Adhesive Foam Rubber 3/8" X 3/16" X 20-3/8" (626-5001-00).							
11‡	Button Hole Plug (Blk) (Happ #52-6214-00)	1	500-6566-00	19G	Push-Button Portals™ Switch (Green)	1	180-5192-04
12	P/F Glass (Tmprd.) 21" X 43" X 3/16"	1	660-5001-00	20	Dual Switch Assembly	1	500-5808-00
ORDERING ABOVE (ITEM 20) ASSEMBLY PART Nº WILL INCLUDE:							
20A Mounting Bracket 1 535-6958-00							
20B Playfield Power Interlock Sw. (Top) 1 180-5136-00							
20C Memory Protect Switch (Bottom) 1 180-5000-01							
Item 20 is secured to Cabinet by: #8 X 1/2" HWH AB (Zinc) (Qty. 2) (234-5101-00)							

Parts Table & Views continue on the next page.

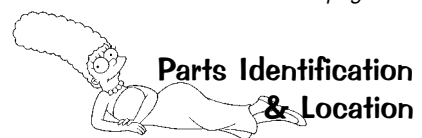

Cabinet - General Parts ■ & Switches □ Continued

Cabinet Back Lights are on the Playfield Back Panel.
Wood Back Panel:
 See Main Playfield - General Parts ■ Metal Rails/Ball Guides ■ & Switches □ (Above), Pages 64-65.
Bulbs & Sockets:
 Playfield - Small Bayonet Type Bulbs and Sockets, Page 72 for Sockets & Bulbs.

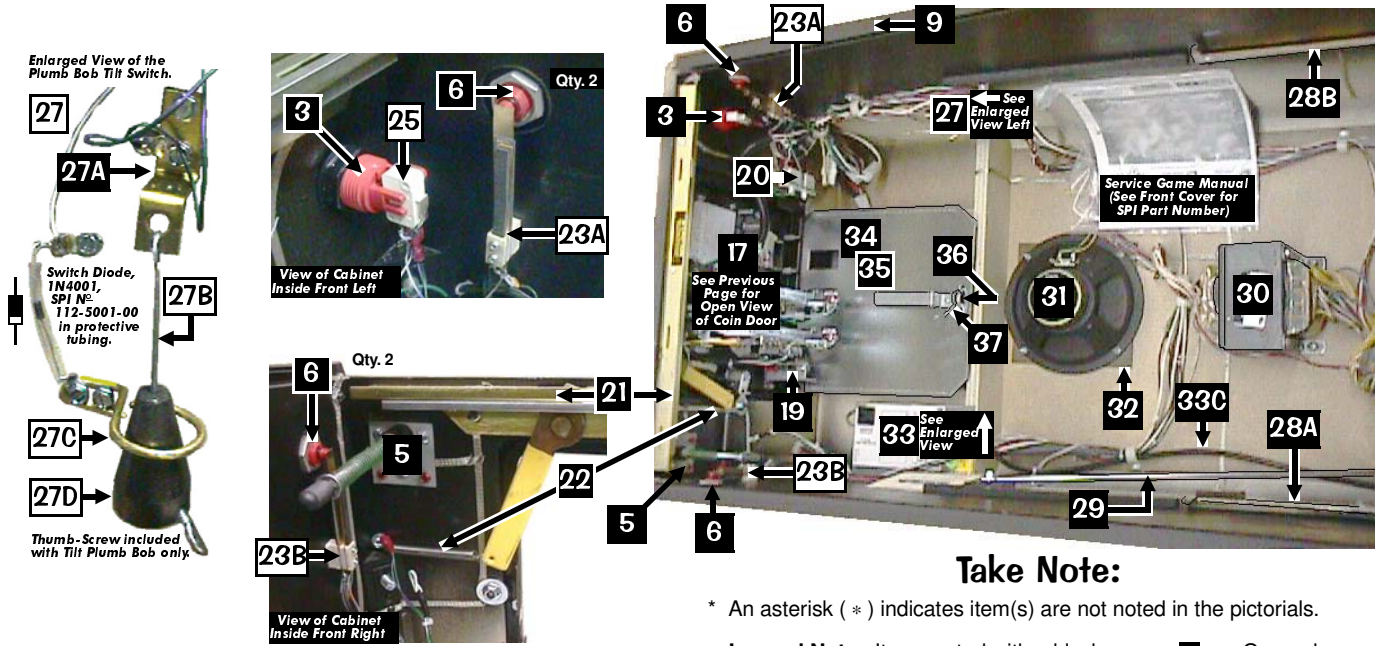
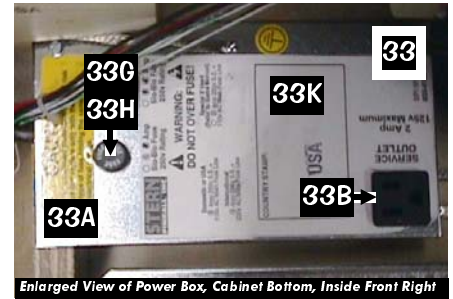

Take Note:

* An asterisk (*) indicates item(s) are not noted in the pictorials.

Legend Note: Items noted with a black square ■ are General Parts. Items noted with a white square □ are Switches.

Nº	INDIVIDUAL PART NAME	QTY.	SPI PART Nº	Nº	INDIVIDUAL PART NAME	QTY.	SPI PART Nº
<i>Parts Table & Views continue on the previous page.</i>							
21	Front Molding Lockdown Assembly	1	500-6509-00	29	Prop Rod	1	535-7553-00
Item 21 is secured by: #10-24 X 1-1/4" Carr. Bolt (Qty. 2) (231-5012-00), #10-24 Keps Nut (Qty. 2) (240-5207-00), #8 X 5/8" HWH AB Zinc (Qty. 4) (234-5102-04) and #10 Washer 7/32" ID X 1/2" OD X 1/16" (Qty. 2) (242-5003-00)				Item 29 is secured by: #10-24 X 1-3/4" Carriage Bolt Sq. Neck (Qty. 1) (231-5022-00), Washer #10 7/32" ID X .5" OD X 1/16" Thk (Qty. 1) (242-5003-00) and #10-24 Nylon Stop Nut (Qty. 1) (240-5206-00)			
22	Lockdown Spring (connected to handle)	1	265-5008-00	30	Transformer 5.7v AC (with Ballast Winding)	1	010-5012-01
23A	Flipper Switch - Self-Cleaning	1	180-5160-00	Item 30 is secured by: 1/4"-20 X 5/8" PPH MS (Zinc) (Qty. 4) (237-5854-00) and 1/4" Split Lock Washer (Qty. 4) (244-5000-00)			
23B	Flipper Sw. - X2 Stack for Lwr./Upr. Flipper(s)	1	180-5164-00	31	Speaker 8" ø Rd. 8010 4Ω	1	031-5007-00
24*	Foam Strip (2 on 23A; 1 on 23B)	3	626-5042-00	32	Speaker Grill 7" X 7"	1	545-5072-03
25	Start Button Switch (ONLY)	1	180-5174-00	Items 31 & 32 are secured by: #6-32 X 1-1/4" Fin Shank Screw (Qty. 4) (237-5883-00) and #6-32 Keps Nut (Qty. 4) (240-5008-00)			
26	Grills 2-1/2" X 18" (on Back & Bottom)	2	545-5072-02	33	Power Input Box Sub-Assy.	1	515-5360-07
27	Cabinet Plumb Bob Tilt Switch	1	See Parts Below	ORDERING ABOVE (ITEM 33) SUB-ASSY. PART Nº WILL INCLUDE:			
ORDER ONLY INDIVIDUAL PART(S) NEEDED:							
27A	Bracket for Hanger Wire	1	535-5221-00	33A	Power Box (Plain)	1	535-5932-00
27B	Hanger Wire	1	535-5319-00	33B	Service Outlet (for USA)	1	180-5008-01
27C	Contact Wire Form	1	535-7563-01	33C	Line Cord 10' ROJ 3" Max.	1	034-5000-10
27D	Plumb Bob Weight (includes Thumb-Screw)	1	535-5029-00	33D	Recessed Cup for Line Cord	1	545-5122-00
Items 27A & 27C are secured by: #8 X 1/2" HWH AB (Zinc) (Qty. 4) (234-5101-00)				33E*	Line Filter	1	150-5000-00
28A	Slide & Pivot Support Bracket - Right	1	535-5990-00	33F*	Varistor TNR159211KM	1	150-5001-00
28B	Slide & Pivot Support Bracket - Left	1	535-5989-00	33G	Fuse 8 Amp 250v Slo-Blo (Domestic)	1	200-5000-05
Items 28A & 28B are secured by: #10-24 X 1-1/4" Carriage Bolt Sq. Neck (3/per) (231-5012-00) and #10-24 KEPS Nut (3/per) (240-5207-00)				33H	Fuse Holder	1	205-5001-00
Pinball Rejuvenation Kit Available: 502-5013-77 This kit consists of 8 oz. Novus Wax #2 Fine (Red) (675-0003-01), cloth and all Rubber Rings & Bulbs used in this Pinball Machine.							
				33I*	On/Off Switch Bracket	1	535-8318-00
				33J	On/Off Rocker Sw. (APEM R2101C5NBB)	1	180-5001-03
				33K	Power Box Decal	1	820-6123-03
				34	Cash Box Plastic Bottom	1	545-5090-00
				35	Cash Box Cover (Validator)	1	535-5013-03
				36	Cash Box Lock Bracket (wire)	1	535-7562-00
				37	Large Hair-Pin Clip	1	535-7772-00
				Optional Meter (+12v DC w/Diode & Bracket)		G-0053-013-102	
				Optional Meter (+12v DC w/Diode, No Bracket)		G-0053-013-102A	

Sec. 4: Parts Id. ...



Main Playfield - General Parts ■, Metal Rails/Ball Guides ■ & Switches (Above)

Nº	ABOVE PLAYFIELD PART NAME	QTY.	SPI PART Nº
PF	P/F Screened w/ Inserts & NO Parts	1	830-5177-00
	P/F Complete w/ Inserts & ALL Parts	1	505-6004-77-77

General Items

1	Arch (Black Metal) no Forks	1	535-8392-01
<p>Item 1 is secured to the playfield by Item 16 and : #10-32 X 5/16" PH FL U/C MS STL Zinc (Qty. 2) (237-6013-00). Usage Note: When replacing the Arch, order new replacement Nelson Protect Strips (not included) (Qty. 2) (545-5212-02).</p>			
2	Instruction Card (USA) ...Simpsons™...	1	755-5177-00
<p>Note: Visit www.sternpinball.com for a PDF copy of the Game Instruction Card which will also have any translated Instruction Cards made for this game. Find Game Link or Archives. Spanish 755-5177-02; German 755-5177-03; Italian 755-5177-04; French 755-5177-05.</p>			
3	Coin Card (2-Sided)	1	755-5400-00
<p>Usage Notes: Use Item 3 (Back: 1 Play 50¢ - 5 Plays \$2) for Adj. 6, Game Pricing, USA 5 Setting, or (Front: 1 Play 50¢ - 3 Plays \$1) for Adj. 6, Game Pricing, USA 8 Setting.</p>			
4	Coin Card (2-Sided)	1	755-5400-02
<p>Usage Notes: Use Item 4 (Front: 1 Play 50¢) for Adj. 6, Game Pricing, USA 2-7 Setting, (Back: is Blank) for Custom Settings. Availability: See Appendix J (back of manual) for all current Coin Cards (USA, Canada, Euro & other International). If this is a non-US Game, Coin Card(s) provided will differ.</p>			
5	Light Reflector (Silver Color Plastic)	5	545-5409-01
6	Mini-Mars Lite Cover (Snap-In) (see Note)	6	550-5030-XX
<p>Item 6 come in various colors, replace XX with the following 2-Digit Numbers: -01 Clear (Qty. 3), -02 Red (Qty. 1), -03 Amber (Qty. 1) & -06 Yellow (Qty. 1). (Note: Additional 1 of each on 2nd Level Playfield: -02 Red, -03 Amber & -06 Yellow)</p>			
7	Itchy with Axe Figurine	1	880-5059-00
8	Scratchy with Hammer Figurine	1	880-5059-01
<p>Items 7-8 are secured by: #8-32 X 3/8" HWH AB (Zinc-Yellow) (Qty. 2/per) (234-5100-00)</p>			
9	Level Assembly	1	515-7214-00
<p>For Individual Items use : .882" 8MM Vial Mtg. Flange (545-6027-00), Level .8mm Empire #0224 (545-6001-01) or Level Bracket (535-9010-00). Flange secured by: #6-32 X 1/4" PPH MS (no Sems) Zinc (237-5500-00) and #6-32 Keps Nut (240-5008-00)</p>			
<p>Item 9 is secured to the wood rail by: #6 X 1/2" HWH AB Zinc Red (Qty. 2) (234-5001-02)</p>			
10	Pinball (Steel) 1 1/8" Ø (1 isaptive)	6	260-5000-00
11*	Plug-Cap (3/16") Black Plastic	0	545-5232-01
<p>Note: Item 11 should plug hole if a Center Post (@ Drain) is used, then removed.</p>			

Brackets with Spinner or Wire Gates

12	Spinner Bracket (Narrow)	1	535-8684-00
<p>Item 12 is secured by: #6 X 1/2" HWH AB Zinc (Red) (Qty. 2) (234-5001-02)</p>			
13	1-Way Gate Mounting Bracket (Large)	1	535-5269-02
	Wire Gate (for above)		535-5307-02
14	1-Way Gate Mounting Bracket (Small)		535-5269-03
	Wire Gate (for above)		535-5307-03

Brackets for Mounting

15	Playfield Hanger Bracket	2	535-8385-00
<p>Item 15 is secured to the P/F by: #8-32 X 7/8" HWH MS Zinc (Qty. 2/per) (237-5890-00)</p>			
16*	Bracket, Back Panel Support	2	535-8964-00
<p>Item 16 is shown in the General Parts (Below) on the opposite of the next Page (66).</p>			
17	Arch Retaining (Hold-Down) Brackets	2	535-8394-00
<p>Item 17 is secured to the P/F by: #8 X 1/2" HWH AB (Zinc) (Qty. 3/per) (234-5101-00)</p>			
18	Switch Base Plate (Black)	1	535-5195-00
<p>Item 18 is secured by: #8-32 X 1/2" HWH AB (Zinc) (Qty. 2) (234-5101-00)</p>			
19	Bracket, Back Panel Front Guide	1	535-6896-00
20	Bracket (Black), LED Mode Sign	1	535-6896-00
<p>Items 19 & 20 are secured by: #8-32 X 3/4" HWH Swage (Ser) Zinc (Qty. 5) (237-5975-02)</p>			
21	Platform (Black), Monorail Support	1	535-9112-01
<p>Item 21 is secured by: #6-32 X 3/8" PPH MS Sems (Zc) (Qty. 1) (232-5201-00), #6 Washer (Qty. 1) (242-5001-00) and 1-3/4" X 1/4" Hex Spacer #6-32 Tap (Qty. 1) (254-5008-10)</p>			
22	Ramp Mounting Bracket	3	515-6508-00
<p>Item 22 is secured by: #6 X 1/2" PTH AB (Zinc) (Qty. 2/per) (237-5809-00)</p>			

Brackets for Ball Stops, Traps or Protect

23	Snubber Bracket	1	535-8250-01
<p>Item 23 is secured by: #8-32 X 1-1/4" HWH MS (Qty. 2) (237-6137-00), #8 Washer .170" ID X 1/2" OD X .042" (Qty. 2) (242-5015-00) and #8-32 Nylon Stop Nut (Qty. 2) (240-5102-00)</p>			
24	Bracket, Plastic Piece -16 Protect	1	535-9219-00
25	Bracket, Plastic Piece -18 Protect	1	535-9220-00
<p>Items 24 & 25 are secured by: Washer 1/4" ID X 1/2" OD X 1/16" (Qty. 2/per) (242-5008-00) and #6-32 Nylon Stop Nut (Qty. 2/per) 240-5005-00</p>			
26	Bracket, Ball Drop Guide (Rt. Return)	1	535-9259-00
27	Bracket, VUK Channel (Top Left)	1	535-9263-00
<p>Item 27 is secured by: #8 X 1/2" HWH AB (Zinc) (Qty. 7) (234-5101-00)</p>			

Nº	ABOVE PLAYFIELD PART NAME	QTY.	SPI PART Nº
----	---------------------------	------	-------------

Wood Back Panel & Wood Rails

28	Back Panel (Blue Wood)	1	525-5618-00
<p>Item 28 is secured by: #8 X 1/2" HWH AB (Zinc) (Qty. 4) (234-5101-00)</p>			
29	Wood Rail 8" (Bottom Left Side P/F Edge)	1	525-5007-07
30	Wood Rail 12" (Top Left Side P/F Edge)		525-5007-44
31	Wood Rail 15" (Bot. Right Side P/F Edge)	1	525-5007-12
32	Wood Rail 21-3/16" (Top Rt. Side P/F Edge)	1	525-5007-50
33	Wood Rail (Shooter Lane, Chamfered)	1	525-5619-01
<p>Items 29-33 are secured by: #6 X 1-1/4" PPH A (Zinc) (Qty. 13 total) (237-5804-00)</p>			

Metal Flat Rails, Wire Forms & Ball Guides

34	Metal Rail (Center Drain under Arch)	1	535-8393-00
35	Metal Rail (Entrance)	1	535-9080-00
36	Metal Rail (Main Loop)	1	535-9082-00
37	Metal Rail (Main Loop Inside)	1	535-9083-00
38	Metal Rail (Mini Loop)	1	535-9084-00
39	Metal Rail (Mini Loop Inside)	1	535-9085-00
40	Metal Rail (Top Middle)	1	535-9086-00
41	Metal Rail (Mini Inner Loop)	1	535-9206-00
<p>Items 34-37, 39-40 are secured at Tabs by: #8 X 1/2" HWH AB (Zinc) (Qty. 1/per tab) (234-5101-00) Item 35 is also secured at Tabs by: #6 X 3/8" HWH AB (Zinc) (Qty. 4) (234-5000-00) Items 37 & 39 are also secured at Tabs by: #8 Washer (Qty. 1/per) (242-5005-00) and #8-32 Nylon Stop Nut (Qty. 1/per) (240-5102-00) Items 38 & 41 are secured at Tabs by: #8 X 1/2" HWH AB (Zinc) Black (Qty. 1/per tab) (234-5101-01)</p>			
42	Metal Wire Form 2.25" (Ø .092")	1	535-5300-12
43	Metal Ball Guide 2-5/16" (Ø .162")	1	535-6492-10
44	Metal Ball Guide 3-3/4" (Ø .12")	1	535-5356-03
45	Metal Ball Guide (Return - Left)	1	535-7560-00 or -9278-00
46	Metal Ball Guide (Return - Right)	1	535-7560-01
47	Metal Ball Guide (Left Drain)	1	535-9092-00
48	Metal Ball Guide (Right Drain)	1	535-9092-01
<p>Items 42-48 are secured by the ends tapped into the playfield. Take care if removing.</p>			
49	Metal Ball Guide Wire (back of Homer)	1	535-9264-00

Miscellaneous Metal & Plastic Ramps

50	Steel Ramp (Monorail)	1	535-9111-00
51	Wire Ramp (Monorail to Rt. Return)	1	515-7235-00
52	Wire Ramp (... to Left Return)	1	515-7234-00
<p>Items 51 & 52 are secured by: #8 Washer .170" ID X 1/2" OD X .042" (Qty. 12) (242-5015-00) and #6-32 X 3/8" PPH MS Sems (Qty. 7) (232-5201-00) onto various Hex Spacers: Item 51 2-1/4" X 1/4" H.S. (254-5008-18) + 1" X 1/4" H.S. (254-5008-06) and Item 52 1-3/4" X 1/4" H.S. (Qty. 2) (254-5008-10) + 1/2" X 1/4" H.S. (254-5008-03) + 5/8" X 1/4" H.S. (254-5008-02)</p>			
53	Steel Ramp with Ramp Flap	1	515-7271-00
<p>Item 53 is secured by: #4 X 5/8" PPH (Black) (Qty. 2) (237-5833-00) For Individual Items use : Ramp (Steel, No Parts) (535-9201-00), Ramp Flap (535-9095-00), Rivet, 1/8" Ø X 3/16" Lg. (Qty. 2) (249-5001-00) and #6 Lock Washer (Qty. 2) (246-5000-00)</p>			
54	Plastic Ramp, Middle	1	545-6045-00
<p>Item 54 is secured by: #6-32 X 3/8" PPH MS Sems (Zinc) (Qty. 5) (232-5201-00), #6 Washer (Qty. 5) (242-5001-00) and 2-5/8" X 1/4" Hex Spacer #6-32 (Qty. 5) (254-5008-08)</p>			

Switches & Misc. PC Board

A	Micro Switch (X1 Left Ramp; X2 Right Ramp)	3	180-5190-28
B	Micro Switch, Spinner (1 -1/4")	1	180-5010-04
<p>Items A/B require a Switch Body Protect Plate (Qty. 1/ea.) (535-6539-00) & is secured by: #2-56 X 1/2" HWH Sr (Qty. 2) (237-5937-02) and #2-56 Hex Nut (Qty. 2) (240-5301-00).</p>			
C	Micro Switch (Roller Actuator, Lite Force)	1	180-5119-02
<p>Item C is sandwiched between 2 Switch Mounting Plates (535-9194-00) which is secured thru Item 17 by: #6-32 X 5/8" HWH Swage (Serr) Zinc (Qty. 2) (237-5976-04)</p>			
D	LED PCB (Mode Signifier)	1	520-5225-00
<p>Item D is secured to Item 20 by: #6-32 X 5/8" PEM Stud-FH-632-10 Zinc (Qty. 3) (237-6131-10), #6-32 Keps Nut (Qty. 3) (240-5008-00) and #6-32 Nylon Stop Nut (Qty. 3) (240-5005-00). More information and views in Sec. 5, Chp. 4, on Pages 142-143.</p>			

Pinball Rejuvenation Kit Available: 502-5013-77

This kit consists of 8 oz. Novus Wax #2 Fine (Red) (675-0003-01), cloth and all Rubber Rings & Bulbs used in this Pinball Machine.

For Assemblies, Ramps, Individual Parts, Figurines and 2nd Level Playfield General Parts not listed on this page, view the Blue Pages (75-98).



Main Playfield - General Parts ■, ...Rails... ■ & Switches □ (Above) Continued

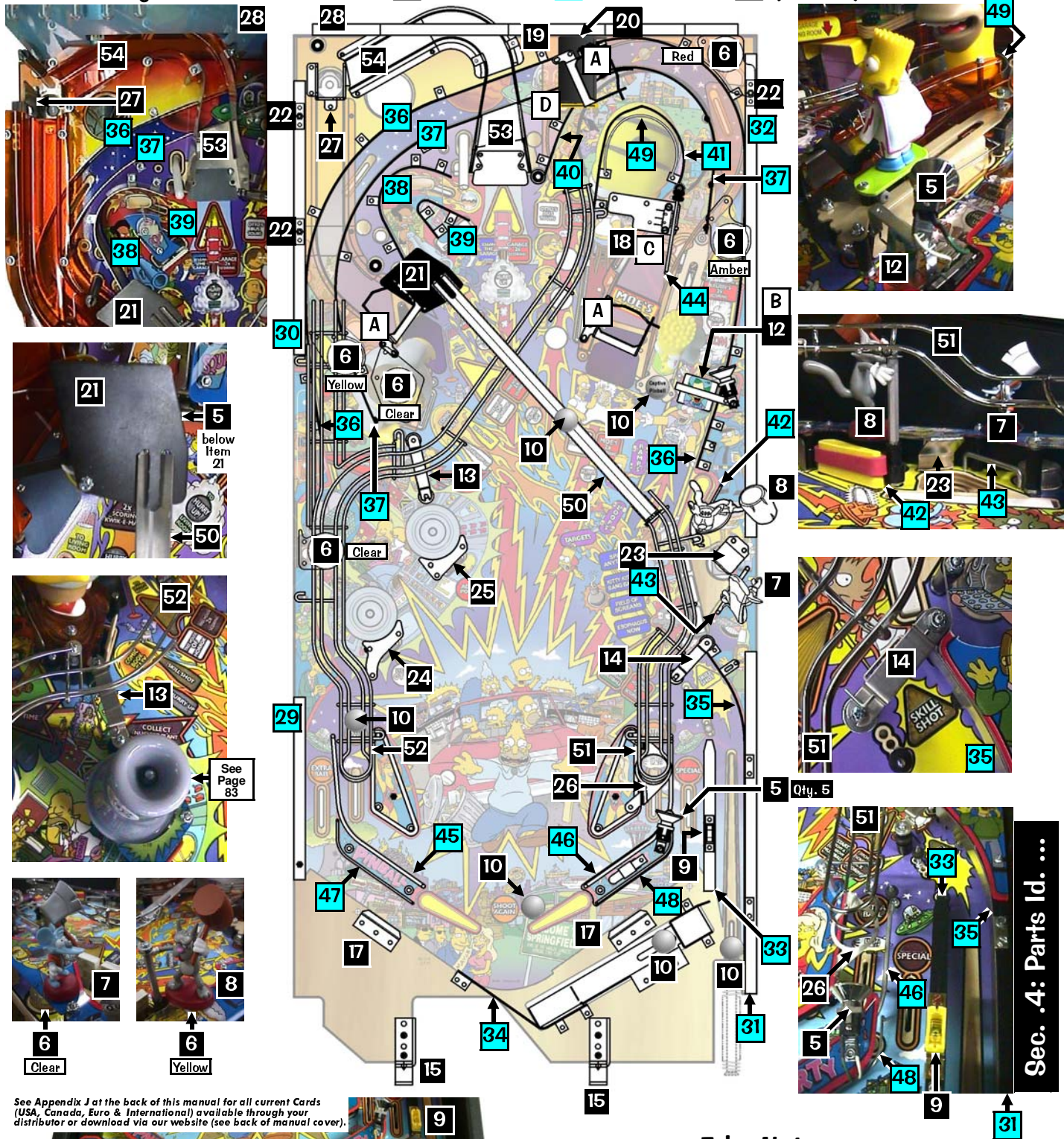

See Appendix J at the back of this manual for all current Cards (USA, Canada, Euro & International) available through your distributor or download via our website (see back of manual cover).

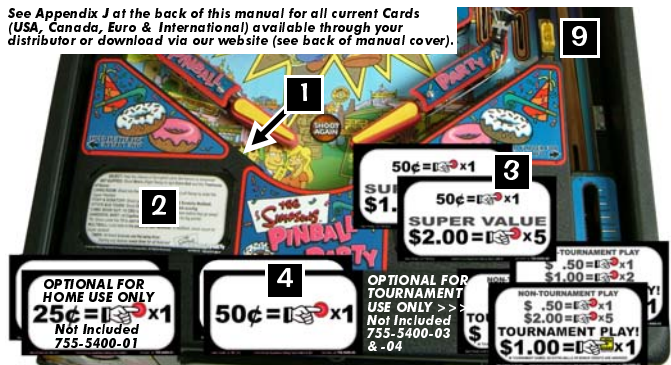

Take Note:

1. Some items or parts may be included with or associated with a Major Assembly or Ramp Assembly; see the Blue Pages, Sec. 4, Chp. 2. for parts required not appearing on this page. If you still cannot find the part required, Call Stern Pinball, Inc. © Technical Support, 1-800-542-5377 or 1-708-345-7700 (Opt. 1).
2. Items 1, 12, 24, 25, 27 & D have associated **Individual Plastics and/or Decals**. These pieces are not available individually. For the Plastic and/or Decal Kits (or views), see the page after next, **Main Playfield & Mini-Playfield - Plastics & Decals, Page 67**.
3. **Legend Note:** Items noted with a black square ■ are General Parts. Items noted with a cyan square ■ are Rails. Items noted with a white square □ are Switches and Misc. PC Board(s).

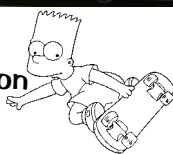

Main Playfield - General Parts & Switches (Below)

Nº BELOW PLAYFIELD PART NAME QTY. SPI PART Nº

General Items

1	Insulation Fiche Paper (under Top Rt. Flip)	1	545-5721-00
2	Diode Terminal Strip 2-Lug (810) Isolated	2	055-5203-00
<i>Note: Item 2 (Qty. 1) is located in the Cabinet on the Coin Door.</i>			
3	Diode Terminal Strip 3-Lug (813) Isolated	1	055-5204-03
4	Diode Terminal Strip 5-Lug (824) Isolated	1	055-5204-05
5	Diode Terminal Strip 7-Lug Isolated	3	055-5204-07
<i>Items 2-5 are secured by: #6 X 3/8 HWH AB Zinc (Qty. 1-2/per) (234-5000-00).</i>			
<i>Note: 1N4004 Diodes (112-5003-00) are used in all Diode applications. 1N4001 Diodes can be used for Switches and/or Lamps. See Sec. 5, Chp. 2, P/F Diode Terminal Strip...</i>			
6	3A 250v Slo-Blo Fuse	6	200-5000-08
	Fuse Clip Holder (Socket)	6	205-5000-01
<i>Item 6 is secured by: #6 X 1/2" PPH AB (Qty. 1/per) (237-5805-00)</i>			
<i>Note: Item 6, Fuse Clip Holder (Socket) 205-5000-01 is part of a set of 12 (205-5000-12). You can order them as individuals (...-01) or a set of 12 (...-12).</i>			
7*	Diode Terminal Strip/Fuse Decals A-F		820-6221-77
<i>Note: For Decal Descriptions & Locations, see Sec. 5, Chp. 2, Playfield Wiring, Page 105.</i>			
8	Wood Spacer (VUK)	1	525-5548-00

Brackets for Mounting

9	Playfield Support Slide Bracket	2	535-6862-02
<i>Item 9 is secured by: #8 X 1/2" HWH AB (Zinc) (Qty. 2/per) (234-5101-00) and #8-32 X 5/8" HWH Swage (Serr) Zinc (Qty. 1/per) (237-5975-03)</i>			
10	Edge Slide Bracket (Extended)	2	535-5988-01
<i>Item 10 is secured by: #4 X 1/2" PFH (Zinc) (Qty. 5/per) (237-5840-00)</i>			
11	Pivot Pin Bracket Welded Assembly	2	500-5329-03
12	Switch Mounting Plate (Black)	2	535-9194-00
13	Switch Base Plate (Black)	1	535-9195-00
<i>Items 12 & 13 are secured by: #6-32 X 5/8" HWH Swage (Ser) Zinc (Qty. 2) (237-5976-04) and #6-32 Nylon Stop Nut (Qty. 2) (240-5005-00)</i>			
14	Switch Bracket (Shooter Lane & Eject Hole)	2	535-6173-00
<i>Item 14 is secured by: #6 X 3/8" HWH AB (Zinc) (Qty. 2/per) (234-5000-00)</i>			
15	Switch Back Plate (Stand-Up Target)	8	535-6452-00
	Target (Stand-Up) Bracket	8	535-6896-00
<i>Item 15 requires: Foam Pad (Qty. 1/per) (626-5029-00) on Target Bracket.</i>			
16	Bracket, Back Panel Support	2	535-8964-00
<i>Item 16 secures Item 28 (prev. page) by: #8 X 1/2" HWH AB (Zinc) (Qty. 3) (234-5101-00)</i>			

Switches & Misc. PC Boards

A	Micro Sw. (Roller Actuator, Lite Force)	4	180-5119-02
B	Micro Switch (at Shooter Lane)	1	180-5157-00
C	EOS Switch Flipper (on Flippers)	2	180-5149-00
D	Stack (Blade) Switch (on Slingshots)	4	180-5054-00
E	Micro Sw. Roll-Over Right Brkt. Assy.	7	500-6227-02
<i>Item E is secured by: #8 X 1/2" HWH AB (Zinc) (Qty. 2/per) (234-5101-00)</i>			
F	Micro Sw. (Heavy Duty "Y" Flat Actuator)	2	180-5116-01
G	Micro Switch (Long Flat+ Bent End Actuator)	1	180-5186-00
<i>Items A-B / G-F require a Switch Body Protect Plate (535-6539-00) which is secured by: #2-56 X 1/2" HWH Serr (Qty. 2) (237-5937-02) and #2-56 Hex Nut (Qty. 2) (240-5301-00).</i>			
H	Micro Switch (on Pop Bumpers)	3	180-5015-03
i	Micro Switch (for Bart Skateboard)	2	180-5190-48
<i>Item i is secured with Items 12 & 13 above.</i>			
J	Micro Switch (on Drop Target)	3	180-5158-00
K	Switch & Target Assy. Rect. (White)	6	515-6027-08
L	Switch & Target Assy. 1" Round (Wht.)	1	515-5966-08
M	Switch & Target Assy. 1" Round (Org.)	1	515-5966-07
<i>Items K-M are secured by: #8 X 1/2" HWH AB (Zinc) (Qty. 2) (234-5101-00)</i>			
N	Modular S-U Target Narrow (Clear)	1	500-6138-01R
<i>Item N is secured by: #6 X 3/4" PPH (Zinc) (Qty. 2) (232-5003-00)</i>			
<i>Note Items K-N: For better view(s) or entire assembly, see Appdx. I, Pg. 11 (end of manual).</i>			
O	Dual OPTO TRANS Bd. (on Ball Trough)	1	520-5173-00
	Dual OPTO REC Board (on Ball Trough)	1	520-5174-00
<i>Note: For how Items A, C, D, F, H-J, O are secured or for a better view, see Section 4, Chapter 2, Drawings for Major Assemblies & Ramps, on the individual assemblies noted.</i>			
<i>Note: For more details on Item O and a break-down of parts, see Section 5, Chapter 4, Printed Circuit Boards, Page 109.</i>			

Pinball Rejuvenation Kit Available: 502-5013-77

This kit consists of 8 oz. Novus Wax #2 Fine (Red) (675-0003-01), cloth and all Rubber Rings & Bulbs used in this Pinball Machine.

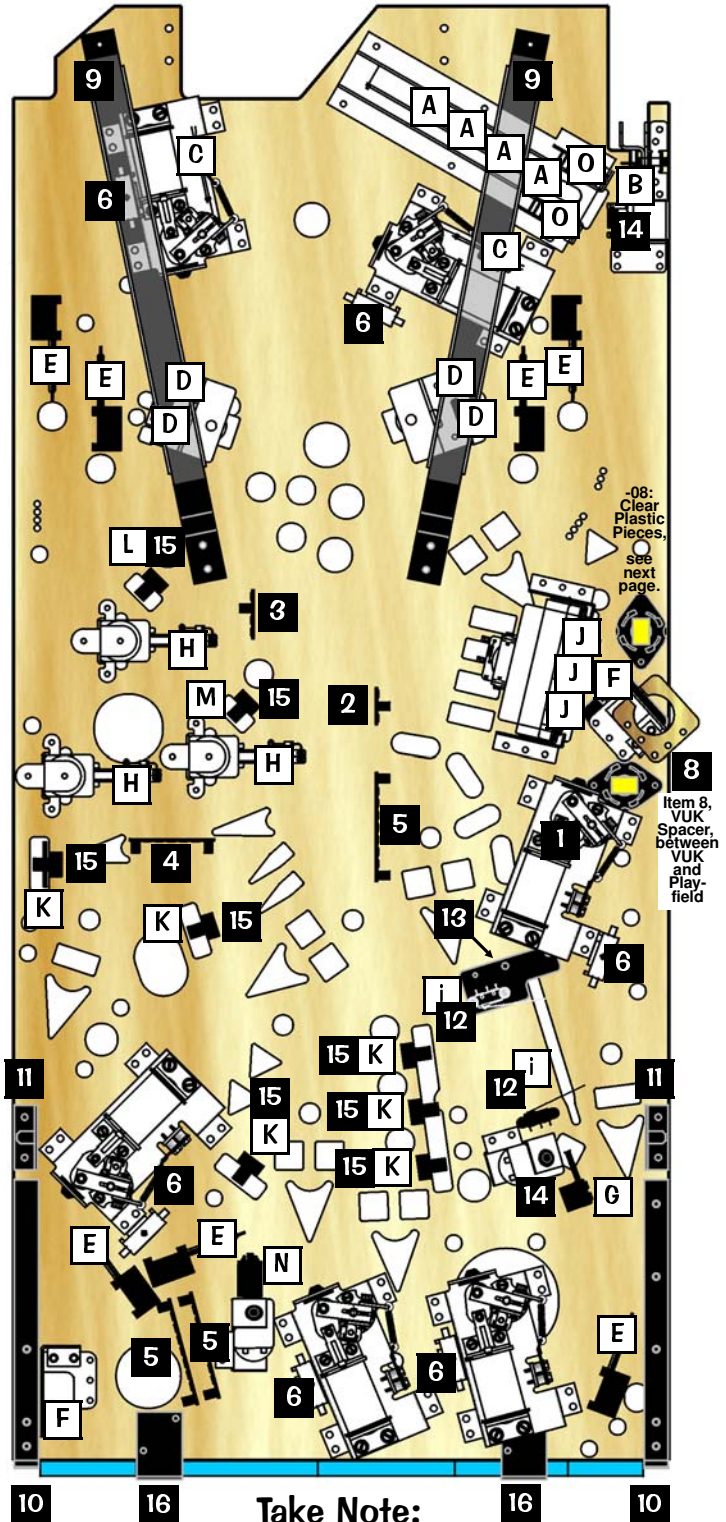

* An asterisk (*) indicates item(s) are not noted in the pictorials.

- For Sockets & Bulbs (drawings & part numbers) see Pgs. 72-74.
- Some items or parts may be included with or associated with a Major Assembly or Ramp Assembly; see the Blue Pages, Sec. 4, Chp. 2. for parts required not appearing on this page. If you still cannot find the part required, Call Stern Pinball, Inc. ® Technical Support, 1-800-542-5377 or 1-708-345-7700 (Opt. 1).
- Legend Note:** Items noted with a black square are General Parts. Items noted with a white square are Switches and Miscellaneous PC Board(s).

Sec. 4: Parts Id. ...



Main Playfield & Mini-Playfield - Plastics (Screened & Clear) & Decals

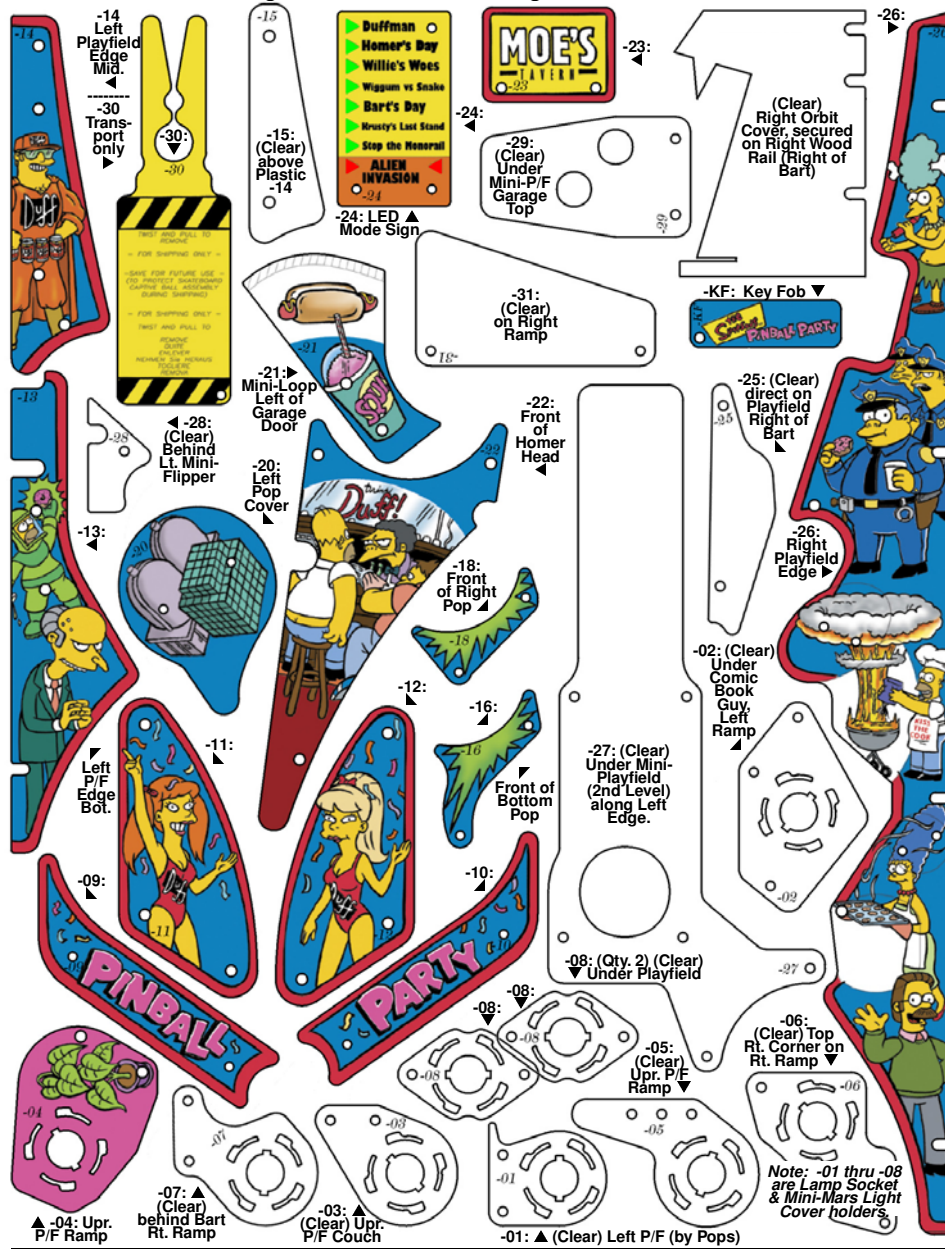

PLASTICS KIT SPI PART N^o
 Kit: Plastics (Screened & Clear)
 (Shown Above the Black Line)
803-5000-77

DECALS KIT SPI PART N^o
 Kit: Game Specific Decals
 (Shown Below the Black Line)
802-5000-77

Attention: No individual Plastic or Decal can be ordered separately, unless noted otherwise*. The individual decals listed on this page which are not included in either Kit are described below.

Some duplicate plastics or decals pieces can be found in the Spare Parts Bag included with this Pinball Machine.

For location purposes, most pieces are identified by a sequential 2-digit number or letter (some numbers may be skipped or not apparent).

Other miscellaneous plastics and/or decals can be found on the Backbox & Speaker Panel Assemblies (Pages 60-61), Cabinet - General Parts (Pages 62-63) and Main Playfield - General Parts & Switches (Below) (Page 66).

- * Not included in the Decals Kit (must be ordered separately):**
- * **Garage Door Cover**
 (Material : Suede Lexan)
*** 820-6329-00**
 - * **Full Playfield Clear Mylar Sheet (Click to View)**
*** 820-5887-00**

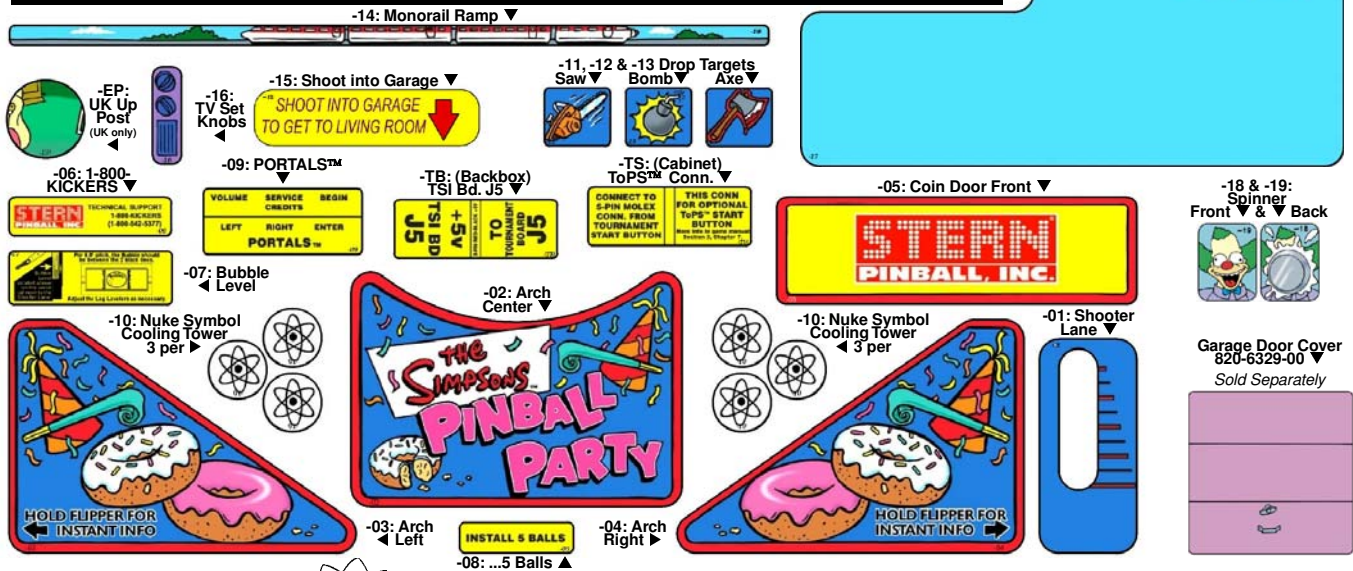
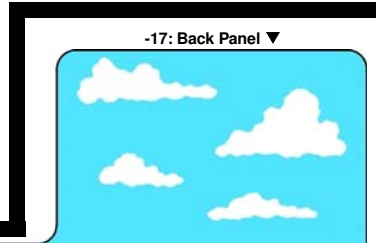

Parts Identification & Location

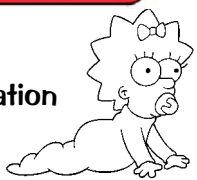

Sec. 4: Parts Id. ...

Main Playfield - Rubber Parts Red & Black (Rings Actual Size) †

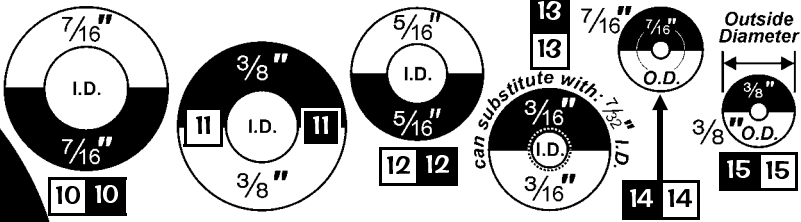
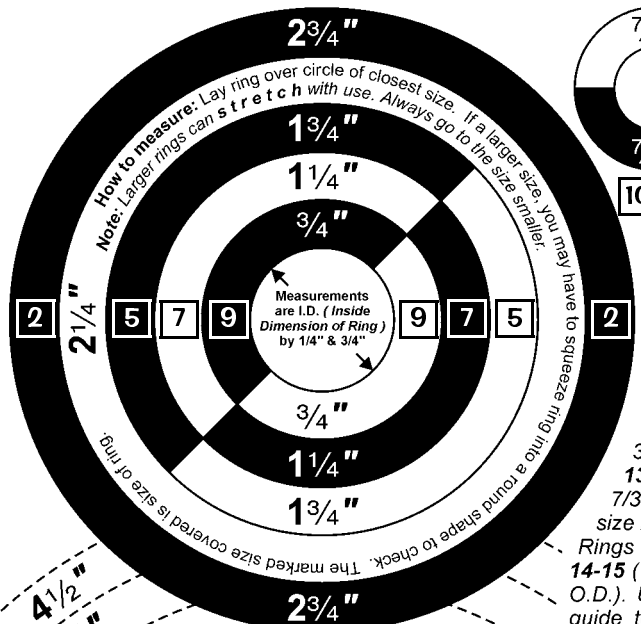

Items 1-13 are measured by the Inside Diameter (I.D.). Items 1-9 and 11 are approximately 1/4" thick. Items 10, 12-15 are approximately 3/16" thick. Item 13 can also be a 7/32" I.D. Ring. The size is imprinted on all Rings except for Items 14-15 (7/16" O.D. & 3/8" O.D.). Use this page as a guide to measure rings where the size imprint or mark does not exist. Size 2 1/4" I.D. (Black or White) was never used. Choose a Ring Size +/- 1/4" I.D. if required.

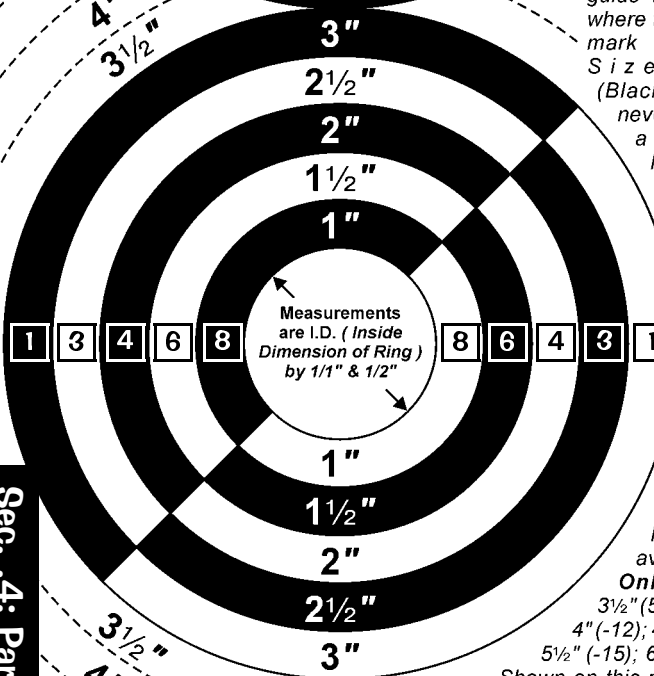

Note: Sizes larger than 3" I.D. currently available in Black Only (Not Used): 3 1/2" (545-5348-11); 4" (-12); 4 1/2" (-13); 5" (-14); 5 1/2" (-15); 6" (-16). Sizes Not Shown on this page, listed in the Parts Table below or are noted with N/U (Not Used) are currently not available.

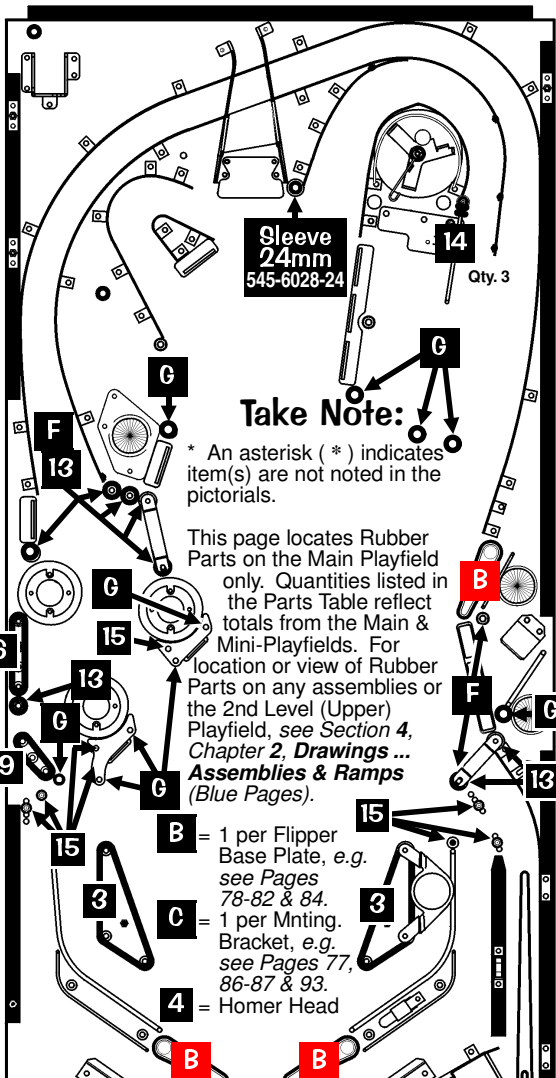

This page locates Rubber Parts on the Main Playfield only. Quantities listed in the Parts Table reflect totals from the Main & Mini-Playfields. For location or view of Rubber Parts on any assemblies or the 2nd Level (Upper) Playfield, see Section 4, Chapter 2, Drawings ... Assemblies & Ramps (Blue Pages).

- B = 1 per Flipper Base Plate, e.g. see Pages 78-82 & 84.
- C = 1 per Mntng. Bracket, e.g. see Pages 77, 86-87 & 93.
- 4 = Homer Head

Note: Item 14, 7/16" O.D. Rings (Qty. 26 of 29) are used to cushion the Bayonet (Metal) Sockets under the playfield.

Sec. 4: Parts Id. ...

Nº	RUBBER PART NAME	QTY.	SPI PART Nº
A*	Small Flipper BLACK Ring		545-5207-00
	Sm. Flipper RED (Soft Duro) Ring	2	545-5207-22
B	Large Flipper BLK (50 Duro) Ring		545-5277-00
	Lg. Flipper RED (Soft Duro) Ring	3	545-5277-22
	Optional Item B Replacements: Lg. YELLOW (50 Duro) Ring (545-5277-04) or Large YELLOW (40 Duro) Ring (545-5277-06)		
C*	Bumper (Deflector Pad)	6	545-5428-00
D*	Bumper (Grommet) 1138 (A60)	5	545-5105-00
E*	Bumper (Post)		545-5009-00
F*	Bumper (Post Sleeve, Short)	7	545-5151-00
	Bumper BLACK (Post Sleeve, Tall)	10	545-5308-00
G	Bumper WHITE (Post Sleeve, Tall)		545-5308-08
H*	O-Ring 1 1/32" x 3/32" x 1/16" (Flipper Buttons)	2	545-5850-00

Nº	SPI PART Nº	QTY.	RUBBER PART NAME	QTY.	SPI PART Nº	Nº
1	545-5348-10		Black 3" I.D. Ring White		-60 N/U	1
2	545-5348-20		Black 2 3/4" I.D. Ring White		-70 N/U	2
3	545-5348-09	2	Black 2 1/2" I.D. Ring White		545-5348-59	3
4	545-5348-08	1	Black 2" I.D. Ring White		545-5348-58	4
5	545-5348-21		Black 1 3/4" I.D. Ring White		-71 N/U	5
6	545-5348-07	1	Black 1 1/2" I.D. Ring White		545-5348-57	6
7	545-5348-06		Black 1 1/4" I.D. Ring White		545-5348-56	7
8	545-5348-05		Black 1" I.D. Ring White		-55 N/U	8
9	545-5348-04	1	Black 3/4" I.D. Ring White		545-5348-54	9
10	545-5348-18		Black 7/16" I.D. Ring White		-68 N/U	10
11	545-5348-03	1	Black 3/8" I.D. Ring White		-53 N/U	11
12	545-5348-02		Black 5/16" I.D. Ring White		545-5348-52	12
13	545-5348-01	13	Black 3/16" I.D. Ring White		545-5348-51	13
14	545-5348-17	29	Black 7/16" O.D. Ring White		-67 N/U	14
15	545-5348-19	12	Black 3/8" O.D. Ring White		545-5348-69	15

† Items with no Qty. (quantity) are not used in this game. Size and/or quantities may change during production.



Main Playfield & Mini-Playfield - Metal Posts (Screws) and Nuts (Actual Size) †

Items 1, 3 & 4 Posts can use 3/8" O.D. Black Ring, 545-5348-19 or White Ring, 545-5348-69.

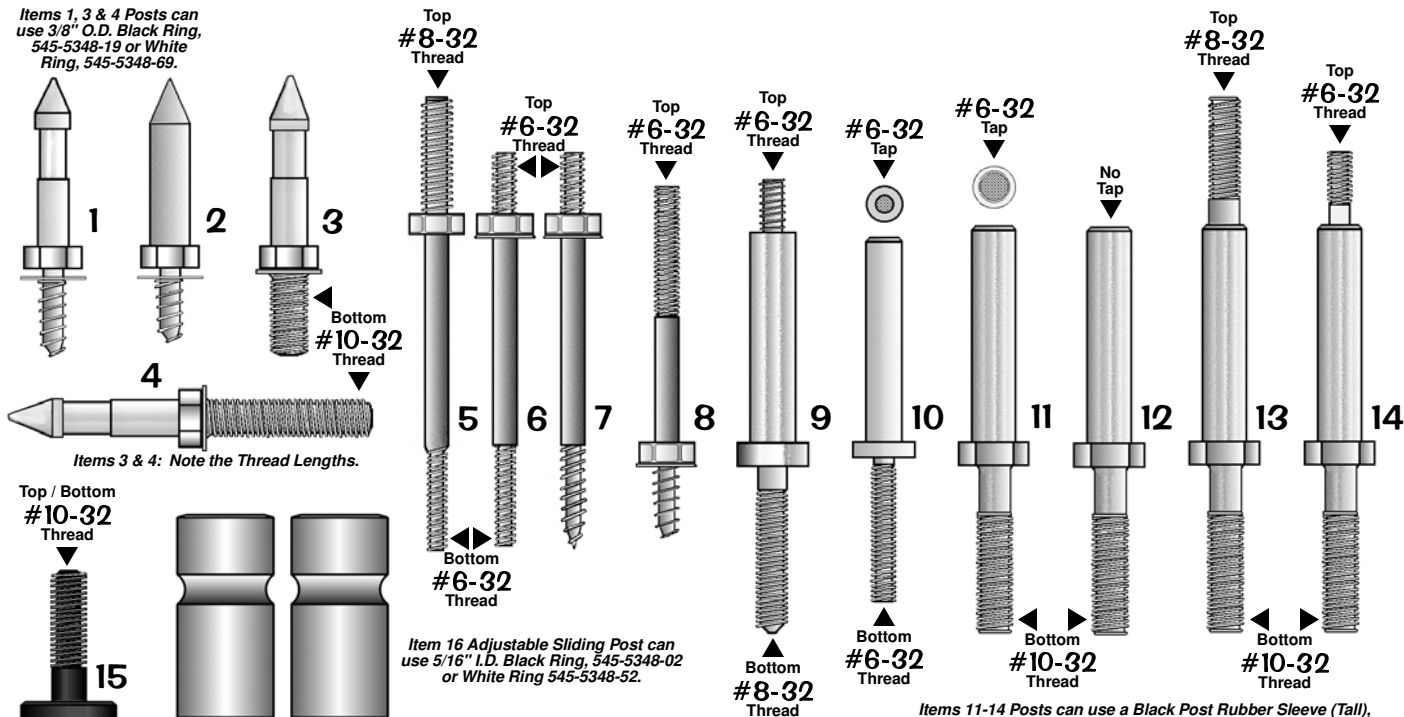

Items 3 & 4: Note the Thread Lengths.

Top / Bottom #10-32 Thread

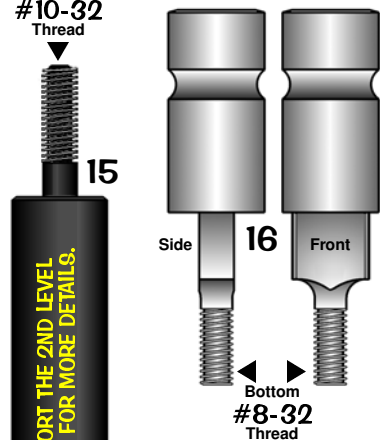

Item 16 Adjustable Sliding Post can use 5/16" I.D. Black Ring, 545-5348-02 or White Ring 545-5348-52.

Items 11-14 Posts can use a Black Post Rubber Sleeve (Tall), 545-5308-00 or White Post Rubber Sleeve (Tall), 545-5308-08.

THIS GAME ONLY: 3 REQUIRED TO SUPPORT THE 2ND LEVEL UPPER PLAYFIELD. SEE THE BLUE PAGES FOR MORE DETAILS.

Items 17 & 18 are typically used with Hex Spacers above the Playfield.

Item 19 is typically used with the bottom Cabinet Speaker (used with #6-32 Nylon Stop Nut, 240-5005-00).

Item 20 is typically used to secure "Item 15 (515-5939-00) in Bumper Bottom Assembly, 515-6459-04".

Note: The "Fins" keep the screw from turning inside the wood hole.

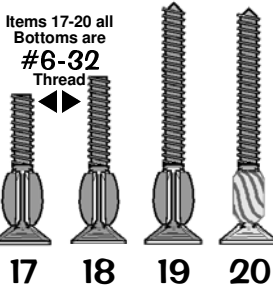

Items 17-20 all Bottoms are #6-32 Thread

Nut Note: All nuts shown with a "✓" are used in this game. The quantities (not specified) vary. The remaining items listed are not used in this game and are noted for reference only (used in prior games).

Shown Below~
• #6-32
Nylon Stop Nut:
240-5005-00 ✓



Top & Side Views

Nylon Stop Nuts Not Shown:

- #6-32 (w/ 1/4" Hex Body): 240-5010-00
- #8-32: 240-5102-00 ✓
- #10-32: 240-5203-00 ✓
- #10-24: 240-5206-00 ✓
- #4-40: 240-5303-00
- #4-40 (18/8 Stainless): 240-5303-01
- 5/16"-18: 240-5316-00

Shown Below~
• #6-32
KEPS Nut (with Star Washer):
240-5008-00 ✓



Bottom & Side Views

KEPS Nuts Not Shown:

- #6-32 (w/ 1/4" Hex Body): 240-5011-00
- #8-32: 240-5104-00
- #10-32: 240-5208-00
- #10-24: 240-5207-00 ✓
- #4-40: 240-5318-00

Shown Below~
• #6-32
Hex Nut (No Star Washer):
240-5004-00 ✓



Top View

Hex Nuts Not Shown:

- #8-32: 240-5103-00
- #10-32: 240-5201-00
- #10-24: 240-5202-00 ✓
- #10-32 X 3/8": 240-5209-00
- 3/4-16: 240-5315-00
- #2-56: 240-5301-00 ✓
- 7/8"-14: 240-5317-00

Shown Below~
• #6-32
T-Nut:
240-5002-00 ✓



Bottom & Side Views

T-Nuts Not Shown:

- #6-32 (w/Side Cut Off): 240-5002-01
- #8-32: 240-5101-00 ✓
- #10-32 (Black Oxide): 240-5007-00
- #10-32 (w/Side Cut Off): 240-5205-00
- #10-24: 240-5200-00

Shown Below~
• 1/4" X 20
Flange Nut:
240-5300-00 ✓

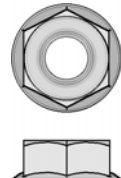

Top & Side Views

Miscellaneous Nuts Not Shown:

- Plastic Pal Nut (on Flipper Buttons): 240-5003-00
- Metal Pal Nut (on Flipper Buttons): 240-5003-01 ✓
- #6-32 Wing Nut: 240-5001-00
- #8-32 Wing Nut: 240-5100-00
- 1/4"-20 Wing Nut: 240-5302-00
- 1/4"-20 Toggle Wing: 240-5324-00

† Items with no Qty. (quantity) are not used in this game. Size and/or quantities may change during production.

Nº	METAL POST NAME	QTY.	SPI PART Nº	Nº	METAL POST NAME	QTY.	SPI PART Nº
1	Mini-Post Wood Screw	2	530-5004-00	11	Post Hex Base #6-32 Tap/#10-32 Bot.	3	530-5332-01
2	Mini-Post Wood Screw (no cut-away)	4	530-5004-01	12	Post Hex Base (No Tap)#10-32 Bot.	3	530-5332-00
3	Mini-Post MS / #10-32 Bot. .4" Thread	2	530-5005-01	13	Post Hex Base #8-32 Top/#10-32 Bot.	10	530-5332-02
4	Mini-Post MS / #10-32 Bot. .875" Thread	10	530-5005-00	14	Post Hex Base #6-32 Top/#10-32 Bot.	10	530-5332-03
5	Post Fasten #8-32 Top / #6-32 Bot.	1	530-5008-00	15	#10-32 Top/Bot. X 3 1/2" P/F Post (Black)	3	530-5612-00
6	Post Fasten #6-32 Top / #6-32 Bot.	10	530-5012-02	16	Adjustable Sliding Post (Brass) #8-32 Bot.	1	530-5621-00
7	Post Fstn. #6-32 Top / Wood Scr. Bot.	12	530-5010-02	17	#6-32 X 3/4" Fin Shank Screw	10	237-5921-02
8	Post #6-32 Top / Wood Screw Bottom		530-5263-01	18	#6-32 X 7/8" Fin Shank Screw	4	237-5921-04
9	Post Fasten #6-32 Top / #8-32 Bot.		530-5007-00	19	#6-32 X 1 1/4" Fin Shank Screw	6	237-5883-00
10	Post #6-32 Tap / #6-32 Bottom		530-5127-00	20	#6-32 X 1 3/16" Spirol Fin Shank Screw	9	237-5957-00

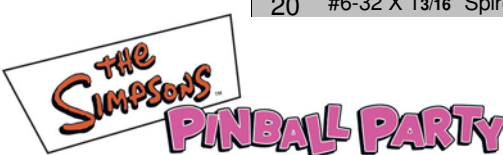

Main Playfield & Mini-Playfield - Hex Spacers (Actual Size) †

Hex Spacers:
#6-32
Tap

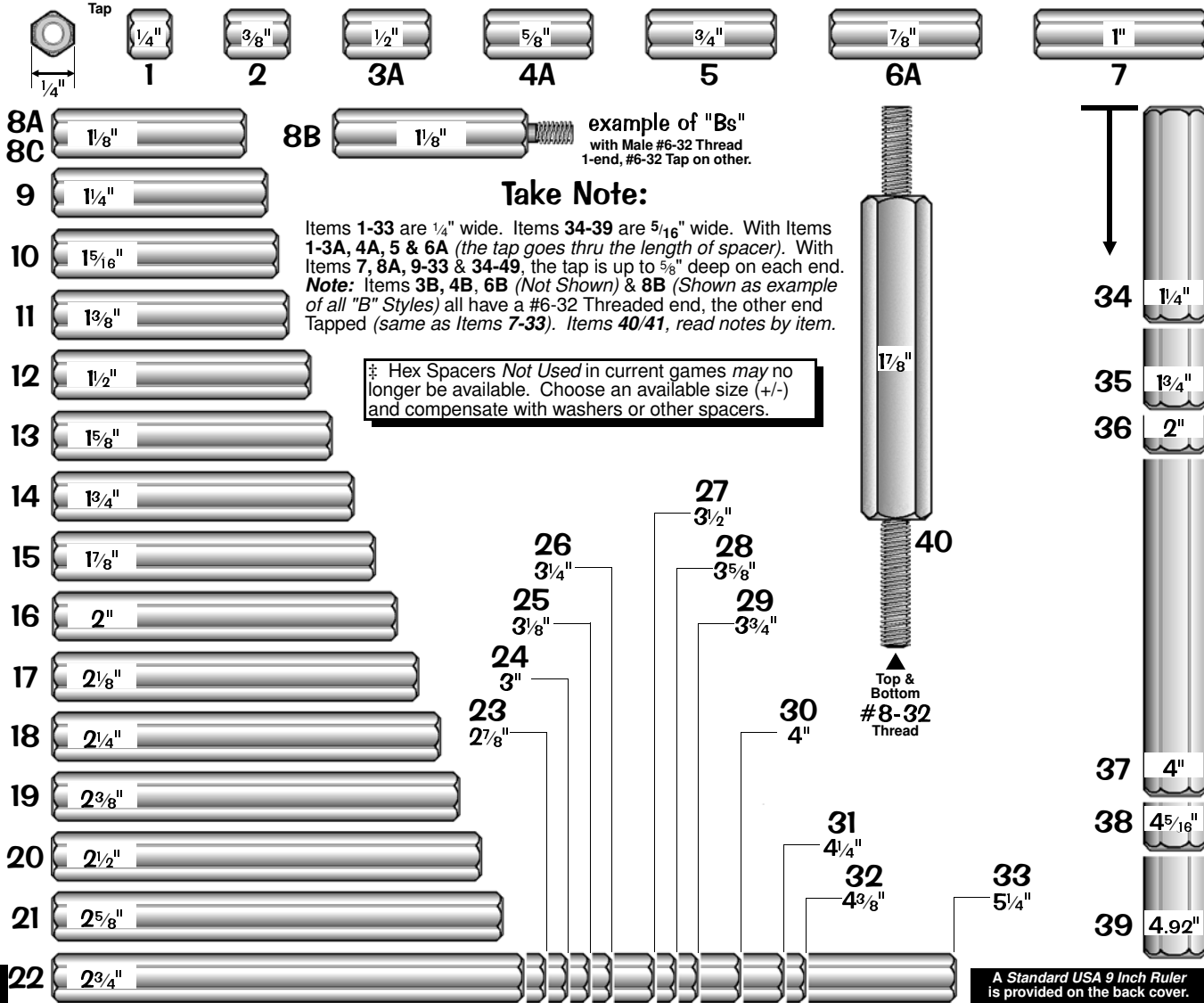

Sec. 4: Parts Id. ...

Nº	HEX SPACER NAME	QTY.	SPI PART Nº	Nº	HEX SPACER NAME	QTY.	SPI PART Nº
1	1/4" X 1/4" : #6-32 Tap (both ends)		254-5008-00	19	2 3/8" X 1/4" : #6-32 Tap (both ends)		254-5008-28
2	3/8" X 1/4" : #6-32 Tap (both ends)		254-5008-12	20	2 1/2" X 1/4" : #6-32 Tap (both ends)	2	254-5008-16
3A	1/2" X 1/4" : #6-32 Tap (both ends)	8	254-5008-03	21	2 5/8" X 1/4" : #6-32 Tap (both ends)	7	254-5008-08
3B*	Identical to 3A with #6-32 Thread end		254-5024-03	22	2 3/4" X 1/4" : #6-32 Tap (both ends)	5	254-5008-15
4A	5/8" X 1/4" : #6-32 Tap (both ends)	1	254-5008-02	23	2 7/8" X 1/4" : #6-32 Tap (both ends)		254-5008-31
4B*	Identical to 4A with #6-32 Thread end		254-5024-02	24	3" X 1/4" : #6-32 Tap (both ends)	3	254-5008-14
5	3/4" X 1/4" : #6-32 Tap (both ends)	1	254-5008-04	25	3 1/8" X 1/4" : #6-32 Tap (both ends)		254-5008-19
6A	7/8" X 1/4" : #6-32 Tap (both ends)		254-5008-05	26	3 1/4" X 1/4" : #6-32 Tap (both ends)		254-5008-26
6B*	Identical to 6A with #6-32 Thread end		254-5024-05	27	3 1/2" X 1/4" : #6-32 Tap (both ends)		254-5008-27
7	1" X 1/4" : #6-32 Tap (both ends)	1	254-5008-06	28	3 5/8" X 1/4" : #6-32 Tap (both ends)		254-5008-25
8A	1 1/8" X 1/4" : #6-32 Tap (both ends)	1	254-5008-17	29	3 3/4" X 1/4" : #6-32 Tap (both ends)		254-5008-36
8B	Identical to 8A with #6-32 Thread end		254-5024-17	30	4" X 1/4" : #6-32 Tap (both ends)	1	254-5008-21
8C	... to 8A with #8-32 Tap (both ends)		254-5031-06	31	4 1/4" X 1/4" : #6-32 Tap (both ends)		254-5008-30
9	1 1/4" X 1/4" : #6-32 Tap (both ends)	2	254-5008-11	32	4 3/8" X 1/4" : #6-32 Tap (both ends)		254-5008-29
10	1 5/16" X 1/4" : #6-32 Tap (both ends)		254-5008-34	33	5 1/4" X 1/4" : #6-32 Tap (both ends)		254-5008-35
11 ‡	1 3/8" X 1/4" : #6-32 Tap (both ends)	4	254-5008-33	34	1 1/4" X 5/16" : #6-32 Tap (both ends)		254-5018-09
12 ‡	1 1/2" X 1/4" : #6-32 Tap (both ends)	1	254-5008-09	35	1 3/4" X 5/16" : #6-32 Tap (both ends)		254-5018-06
13 ‡	1 5/8" X 1/4" : #6-32 Tap (both ends)		254-5008-13	36	2" X 5/16" : #6-32 Tap (both ends)		254-5018-07
14 ‡	1 3/4" X 1/4" : #6-32 Tap (both ends)	2	254-5008-10	37	4" X 5/16" : #6-32 Tap (both ends)		254-5018-03
15 ‡	1 7/8" X 1/4" : #6-32 Tap (both ends)		254-5008-20	38	4 5/16" X 5/16" : #6-32 Tap (both ends)		254-5018-00
16	2" X 1/4" : #6-32 Tap (both ends)	1	254-5008-07	39	4.92" X 5/16" : #6-32 Tap (both ends)		254-5018-04
17	2 1/8" X 1/4" : #6-32 Tap (both ends)		254-5008-32	40	1 7/8" X 3/8" : #8-32 Thread (both ends)		530-5285-00
18	2 1/4" X 1/4" : #6-32 Tap (both ends)	1	254-5008-18				

† Items with no Qty. (quantity) are not used in this game. Size and/or quantities may change during production.



Main Playfield & Mini-Playfield - Posts & Spacers (Actual Size) †

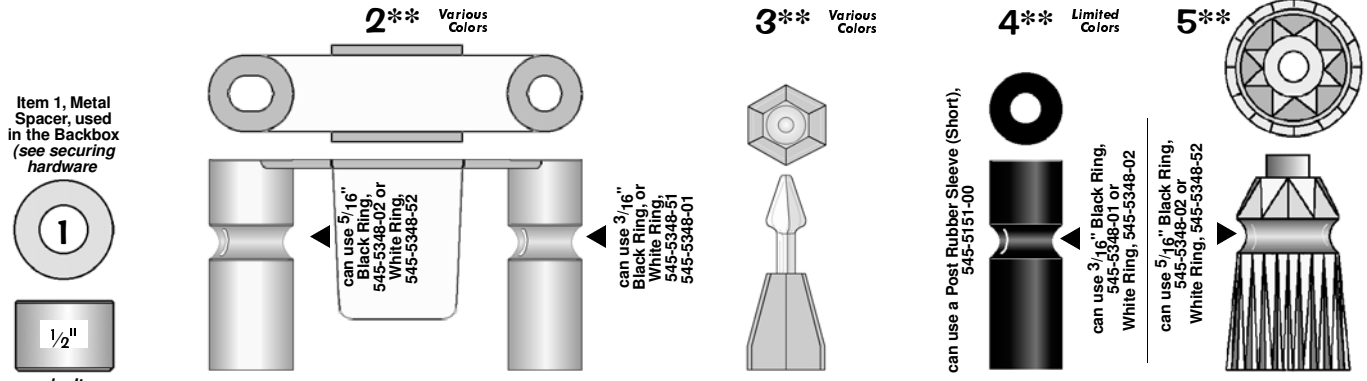

Item 1, Metal Spacer, used in the Backbox (see securing hardware)

1/2" under Items AP-B/-C on Page 61).

Take Note:

PLASTIC PART COLOR CHART					
N ^o	Color	N ^o	Color	N ^o	Color
-00	Black	-06	Yellow	-12	Fluor. Blue
-01	Clear	-07	Orange	-13	Teal Green
-02	Red	-08	White	-14	Gray
-03	Amber	-09	Purple	-15	Luminescent
-04	Green	-10	Fluor. Orange	-16	Gold
-05	Blue	-11	Fluor. Green		

** Items 2, 4 & 5 come in various colors (may not be available in every color). Item 4 is currently only available in the color(s) stated in this game manual (other colors used in prior games may no longer be available). The "-XX" or last 2-Digits in Part N^os which come in various colors, should be replaced with the desired 2-Digit N^o. from the above Color Chart. Some colors may no longer be available for desired item.

30 30-31 are in THIS GAME ONLY

See the Blue Page 90 for usage.

Take Note:

If any one of Items 11-23 Plastic Spacers is not available in the size required, order the smaller sized spacers required to stack sizes together until appropriate size is achieved (e.g. If 1 1/8" is needed but unavailable, order a 1/2" + 5/8" & stack to = 1 1/8").

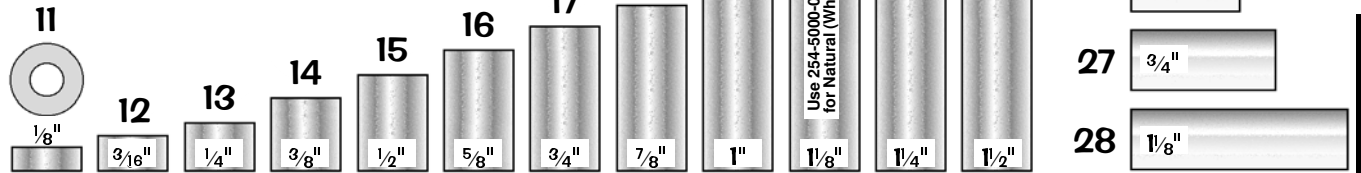

Note the Part N^o & Material Difference

Sec. 4: Parts Id. ...

† Items with no Qty. (quantity) are not used in this game. Size and/or quantities may change during production.

N ^o	POST & SPACER NAME	QTY.	SPI PART N ^o	N ^o	POST & SPACER NAME	QTY.	SPI PART N ^o
1	3/8" X 1/2" Metal Spacer (Backbox)	2	530-5099-00	14	3/8" X 3/8" Plastic Spacer Gray	2	254-5000-12
2**	Top Lane Plastic Mini-Light Hood		550-5061-XX	15	1/2" X 3/8" Plastic Spacer Gray	4	254-5000-01
	Item 2 typically secured by: #6-32 X 1-3/4" PPH MS (Zinc) (Qty. 2/per) (237-5511-00) and Washer 9/64" X 5/16" OD X 1/32" (Qty. 2/per) (242-5017-00)			16	5/8" X 3/8" Plastic Spacer Gray	2	254-5000-14
3***	Mini-Jewel Plastic Post		550-5052-XX	17	3/4" X 3/8" Plastic Spacer Gray	1	254-5000-07
	Item 3 typically secured by: #6 X 3/8" HWH AB (Zinc) (Qty. 1/per) (234-5000-00)			18	7/8" X 3/8" Plastic Spacer Gray		254-5000-11
4**	1 1/16" 1-Groove Plastic Post (Black)	39	550-5059-00	19	1" X 3/8" Plastic Spacer Gray or Black	2	254-5000-04
	1 1/16" 1-Groove Plastic Post (Clear)	1	550-5059-01	20	1 1/8" X 3/8" Plastic Spacer Gray		254-5000-06
5**	1-Groove Jewel Plastic Post		550-5034-XX	21	1 1/8" X 3/8" Plastic Spacer Natural		254-5000-06N
	Items 4 & 5 typically secured by: Post Fastening Screw #6-32 Top / #6-32 Bottom (Qty. 1/per) (530-5012-02, Item 7 Page 69).			22	1 1/4" X 3/8" Plastic Spacer Gray		254-5000-05
6 ‡	1/4" Sif. Rtn. Plastic Spacer White		254-5007-02	23	1 1/2" X 3/8" Plastic Spacer Gray	1	254-5000-08
7 ‡	3/8" Sif. Rtn. Plastic Spacer White		254-5007-01	24	1 15/16" X 3/8" Plastic Spacer Gray	1	254-5000-15
8 ‡	5/8" Sif. Rtn. Plastic Spacer White		254-5007-00	25	1/4" X 5/16" X .144" I.D. Metal Spacer		254-5014-03
9 ‡	3/4" Sif. Rtn. Plastic Spacer White		254-5007-03	26	1/2" X 5/16" X .144" I.D. Metal Spacer	3	254-5014-00
10	1/2" X 1/4" Plastic Spacer White (Narrow)		254-5000-03	27	9/16" X 5/16" X .144" I.D. Metal Spacer		254-5014-04
11	1/8" X 3/8" Plastic Spacer Gray		254-5000-19	28	3/4" X 5/16" X .144" I.D. Metal Spacer		254-5014-01
12	3/16" X 3/8" Plastic Spacer Gray	7	254-5000-18	29	1 1/8" X 5/16" X .144" I.D. Metal Spacer		254-5014-02
13	1/4" X 3/8" Plastic Spacer Gray	14	254-5000-02	30	1" X 5/16" X .144" I.D. Metal Spacer		254-5001-00
				31	2-7/16" X 5/16" X 1/8" o.d. Pl. Sprc. Blk.	1	254-5035-00
					9/16" X 5/16" X 1/8" o.d. Plstc. Sprc. Blk.	2	254-5034-00

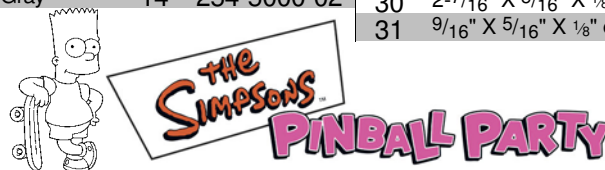

Main Playfield & Mini-Playfield - Small Bayonet Type Bulbs & Sockets (Actual Size) †

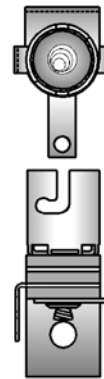
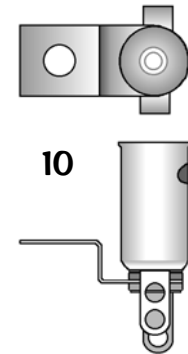
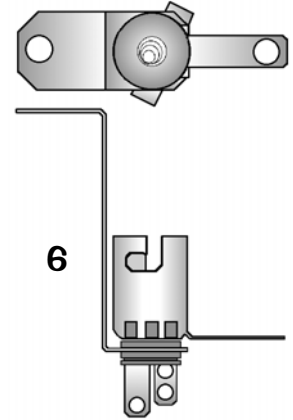
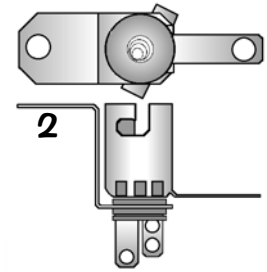
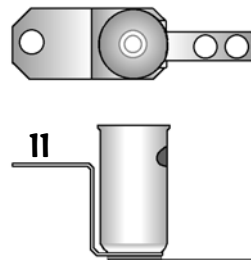
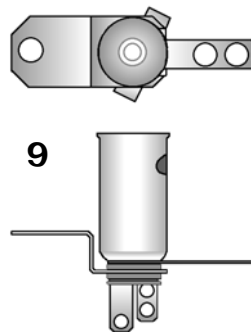
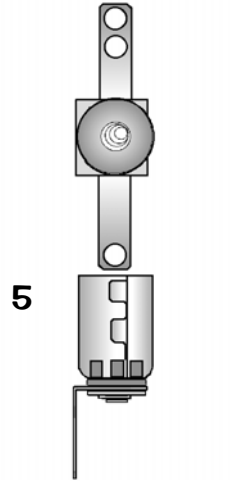
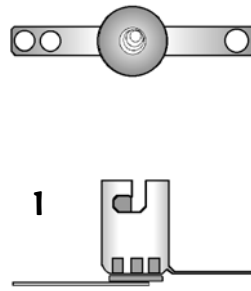
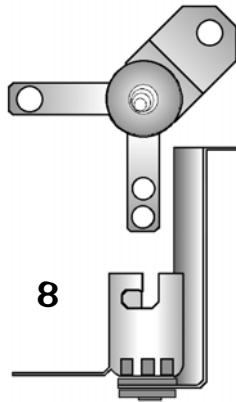
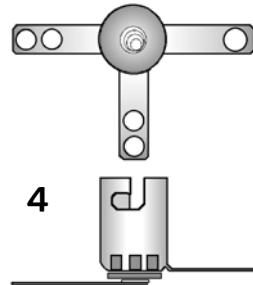
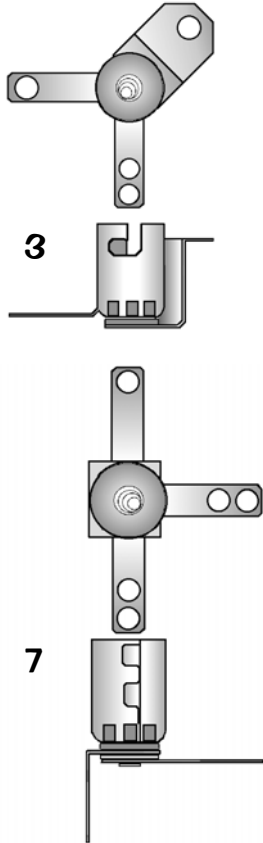
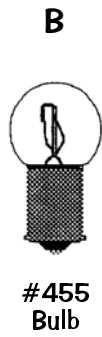
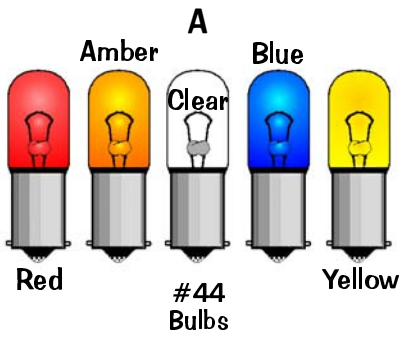

Sec. 4: Parts Id. ...

Nº	SMALL BULB or SOCKET NAME	QTY.	SPI PART Nº
A	#44 Bulb (Clear)	45	165-5000-44
A	#44 Bulb (Red)		165-5053-02
A	#44 Bulb (Amber)		165-5053-03
A	#44 Bulb (Blue)		165-5053-05
A	#44 Bulb (Yellow)		165-5053-06
B	#455 Twinkle Bulb		165-5003-00
1	2-Lug Staple Down Socket	19	077-5000-00
2	3-Lug Stand-Up Short Socket		077-5008-00
3	2-Lug Stand-Up Short Socket		077-5002-00
4	3-Lug Staple Down Socket		077-5001-00
5	2-Lug Laydown Socket	4	077-5003-00
6	3-Lug Stand-Up Long Socket		077-5009-00
7	3-Lug Laydown Socket (3 Lugs Flat)		077-5006-00
8	2-Lug Stand-Up Long Socket		077-5005-00
9	3-Lug Stand-Up Long Shell Socket		077-5013-00
10	2-Lug Stand-Up Lg. Shell Socket (Gls)	22	077-5031-00

Nº	SOCKET NAME	QTY.	SPI PART Nº
11	1-Lug Stand-Up Long Shell Socket		077-5012-00
12	3-Lug Laydown Socket (2 Lugs Bent)		077-5032-00

† Items with no Qty. (quantity) are not used in this game. Size and/or quantities may change during production.

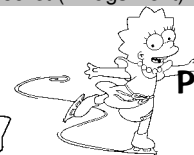

Main Playfield - Large Bayonet Type Bulb and Sockets (Actual Size) †

(None Used in this Game)

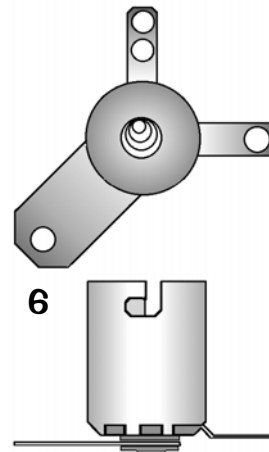
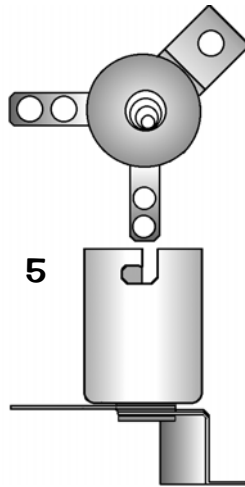
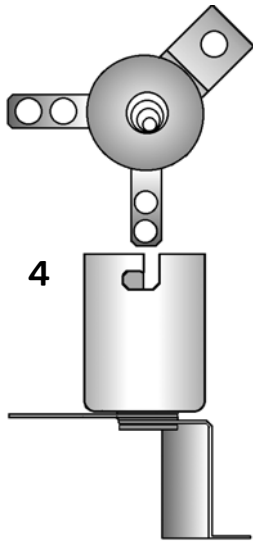
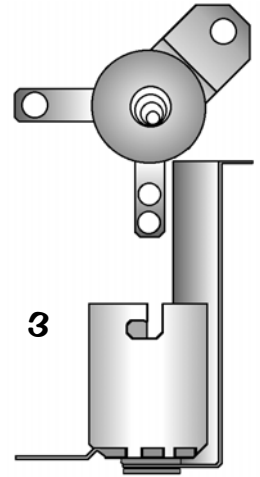
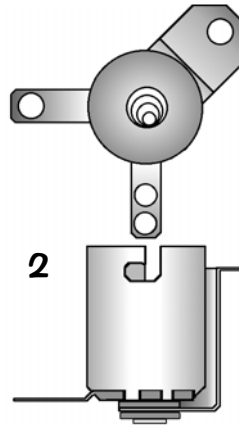
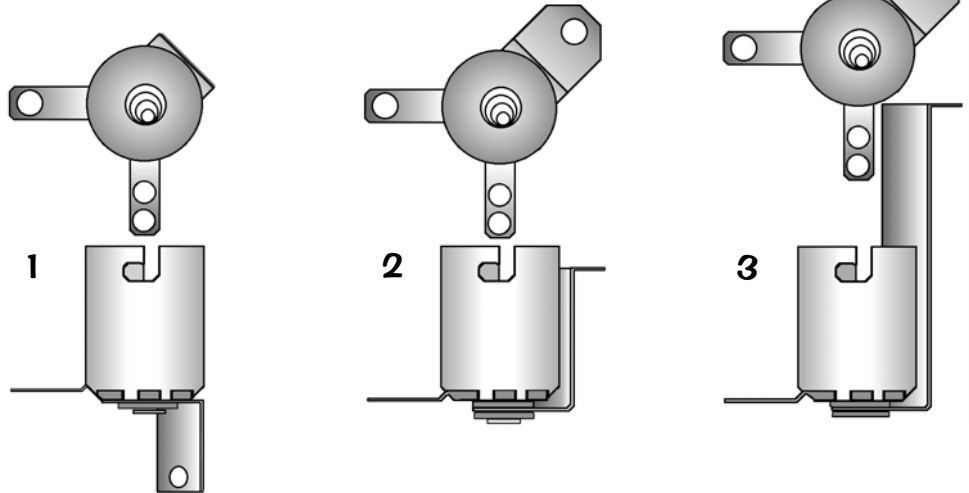
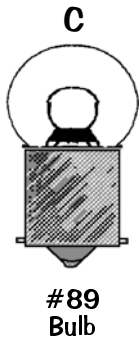

† Items with no Qty. (quantity) are not used in this game. Size and/or quantities may change during production.

Nº	LARGE BULB & SOCKET NAME	QTY.	SPI PART Nº	Nº	LARGE BULB & SOCKET NAME	QTY.	SPI PART Nº
C	#89 Bulb		165-5000-89	3	2-Lug Stand-Up Long Socket		077-5102-00
1	Laydown Standard Socket		077-5100-00	4	Stand-Up Socket Rev. Short		077-5103-00
2	2-Lug Stand-Up Short Socket		077-5101-00	5	2-Lug Stand-Up Small Socket		077-5106-00
				6	Straight Leg Socket		077-5107-00



Main Playfield & Mini-Playfield - Wedge Base Bulbs and Sockets (Actual Size) †

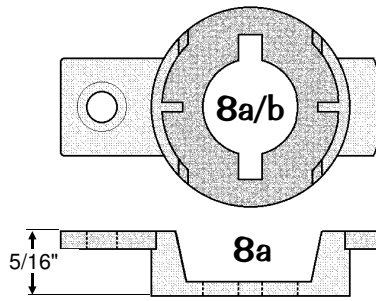
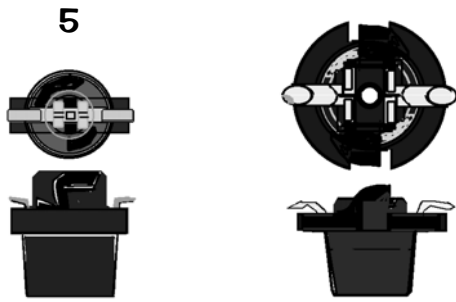
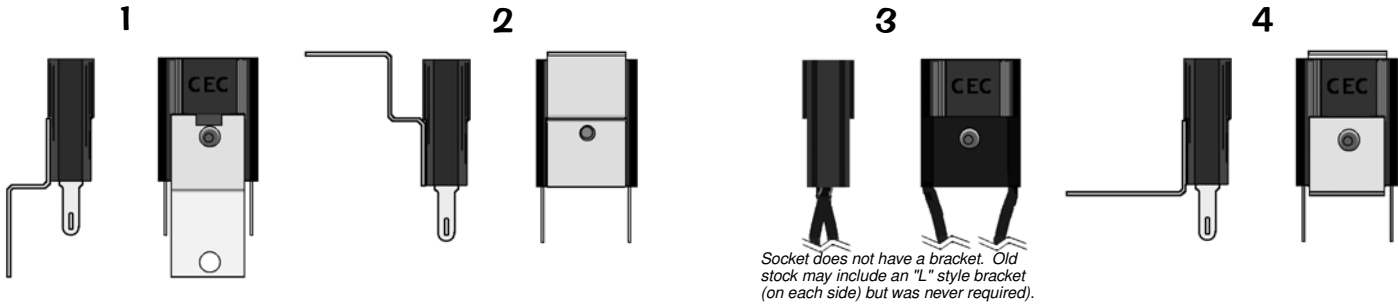
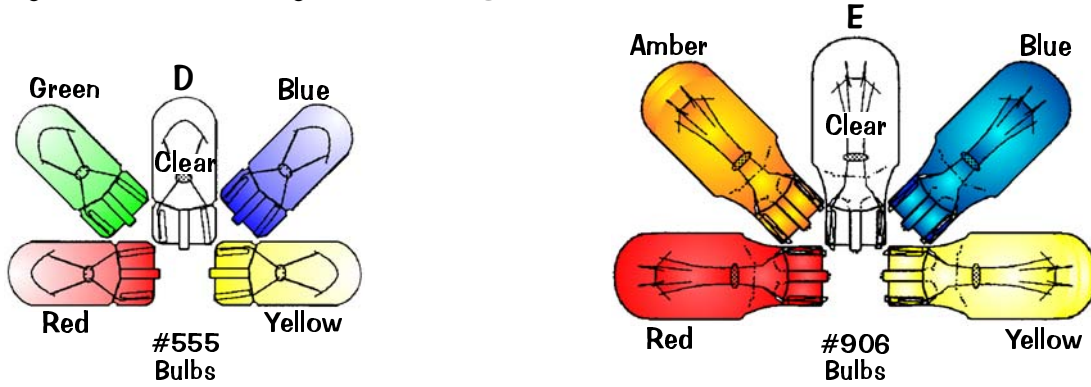

Take Special Note

Item 7a is an IDC (Insulation Displacement Connection) Style Socket (this style is solderless). This socket is secured to the playfield or component by Items 8a or 8b Snap-On Socket Brackets, or may also be snapped into specially cut **Clear and/or Screened Plastic Pieces** (used only when sockets are positioned closely together and/or in a special applications, e.g. on Ramps). If Plastic Pieces are used to mount some 7a or 7b Sockets, it will be noted on the Main Playfield & Mini-Playfield - Plastics & Decals, Page 67.

Take Note:

- * An asterisk (*) indicates item(s) are not noted in the pictorials.
- 1. Item 3 Socket has 2 Wires attached are approximately 12" ea.
- 2. Item 5 Socket **was** used on PC Light Boards to position bulbs vertically; Item 5 Socket is secured by "twisting" into place.
- 3. Item D Bulb (#555) can be used in all sockets, *except* Item 6.
- 4. Item E Bulb (#906) can be used in all sockets, *except* Item 5.
- 5. Item 7a Socket is equipped with a *built-in* Diode, 1N4003 (112-5003-00), however, replacement can be made with a 1N4001 Diode (112-5001-00).
- 6. Item 7b Socket is **NOT** equipped with a diode (Not Required).

Note: Always replace with same type bulb in original application.

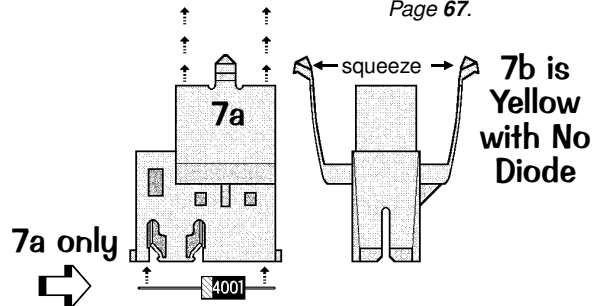

Nº	WEDGE BULB & SOCKET NAME	QTY.	SPI PART Nº	Nº	WEDGE BULB & SOCKET NAME	QTY.	SPI PART Nº
D	#555 Wedge Base Bulb (Clear)	72	165-5002-00	1	Wedge Base Socket (Laydown)	12	077-5026-01
D	#555 Wedge Base Bulb (Red)		165-5054-02	2	Wedge Base Socket (Offset)		077-5029-00
D	#555 Wedge Base Bulb (Green)		165-5054-04	3	W.B. Socket (Bumpers/Special App.)	4	077-5206-00
D	#555 Wedge Base Bulb (Blue)		165-5054-05	4	Wedge Base Socket (Laydown Gl)	1	077-5030-00
D	#555 Wedge Base Bulb (Yellow)		165-5054-06	5	#555 <i>only</i> Wedge Base Socket (Twist)		077-5007-00
E	#906 Wedge Base Bulb (Clear)	13	165-5004-00	6	#906 <i>only</i> Wedge Base Socket (Twist)		077-5016-00
E	#906 Wedge Base Bulb (Red)		165-5004-02	7a	IDC Snap-On Socket	56	077-5216-00
E	#906 Wedge Base Bulb (Amber)		165-5004-03	7b	IDC Snap-On Socket No Diode	12	077-5216-01
E	#906 Wedge Base Bulb (Blue)		165-5004-05	8a	5/16" Ht. Snap-On Socket Bracket	55	545-5760-18
E	#906 Wedge Base Bulb (Yellow)		165-5004-06	8b*	19/32" Ht. Snap-On Socket Bracket		545-5760-19

† Items with no Qty. (quantity) are not used in this game. Size and/or quantities may change during production.

Sec. 4: Parts Id. ...



Drawings for Major Assemblies & Ramps (The Blue Pages)

Overview

Drawings are provided for the Major Assemblies in this game with individual parts of each assembly numbered. Items noted with a white circle ○ are mounted above the playfield; items noted with a black circle ● are mounted below. All numbered parts describe the **NAME, QUANTITY & PART N°**. **ASSOCIATED PARTS (AP-)** are noted and/or viewed with the associated Major Assembly. **Important:** Read all "Take Note:" items.



Ball Shooter (Plunger) Assembly, 500-6146-00-04 (Items 1-8)

Manually launch the ball into play.

Nº	INDIVIDUAL PART NAME	QTY.	SPI PART Nº	Nº	INDIVIDUAL PART NAME	QTY.	SPI PART Nº
1	Housing (Shooter Assembly)	1	535-5067-02	4	Compression Spring (Short Plunger)	1	266-5010-00
<small>Item 1 is secured to the Cabinet by: Support Plate (Qty. 1) (535-5027-00), #10-32 X 1/2" PPH (Sems) Zinc TF (Qty. 3) (237-6033-00), #10 Split Lock Washer (Qty. 3) (234-5003-00) and #6 X 5/8" HWH AB (Zinc) (Qty. 2) (234-5002-00)</small>							
2	Rod Assembly (w/Black Knob)	1	515-6557-00	7	Retaining Ring, 3/8" ø Shaft	1	270-5012-00
3	Comp. (Return) Spring (GRN, .035" ø)	1	266-5001-04	8	Plunger Tip (Black 50 Duro)	1	545-5276-00

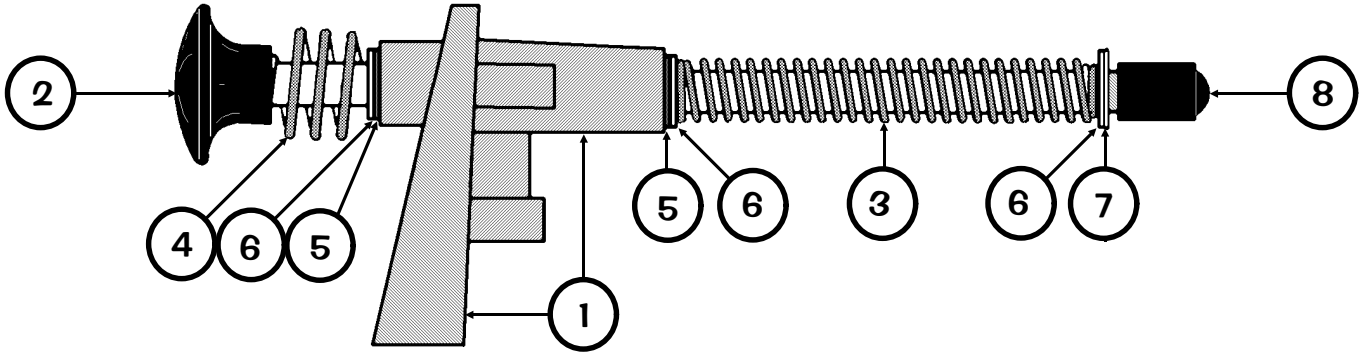

Autoplunger Arm Weld Assembly, 500-6091-00 (Items AW1-AW3) with Autoplunger Coil Assembly, 500-6092-06 (Items 1-6)

Automatically launches the ball into play.

Nº	... ARM WELD PART NAME	QTY.	SPI PART Nº	Nº	'PLUNGER COIL PART NAME	QTY.	SPI PART Nº
AW1	Arm Weld Assembly	1	515-6526-00	1	Autoplunger Coil Bracket Assembly	1	515-6527-00
<small>Item AW1 is secured to Item AW2 by: Retaining Ring, 1/4" ø Shaft (Qty. 1) (270-5002-00)</small>							
AW2	Autoplunger Fulcrum	1	535-7697-00	2	Coil Retainer Bracket	1	535-5203-03
AW3	Nyliner, 1/4" (Thomson #411-FF)	2	545-5423-00	3	Coil, 26-1200	1	090-5044-00T
<small>Coil has a Diode (1N4004) (112-5003-00) positioned @ top (above lugs next to windings).</small>							
<small>For Individual Items use : Plunger 2" Lg. (530-5025-01), Plunger Link (545-5293-00) and Roll Pin 1/8" ø x 5/8" Lg. (251-5008-00) The Plunger Link is secured to the Arm Weld by: Retaining Ring, 1/4" ø Shaft (Qty. 1) (270-5002-00)</small>							
<small>Ordering Note: If 515-5338-00 is unavailable, order the individual part(s) actually required.</small>							
<small>Item 2 is secured to Item 1 by: #8-32 X 1/4" PPH MS (Sems) Zinc (Qty. 2) (232-5300-00)</small>							
<small>Item 1 is secured below the playfield by: #8 X 1/2" HWH AB (Zinc) (Qty. 9) (234-5101-00)</small>							
<small>Item 4 is secured to Item 5 by: #8-32 X 1/4" PPH MS (Sems) Zinc (Qty. 2) (232-5300-00)</small>							
<small>Item 5 is secured to Item 6 by: #8-32 X 1/4" PPH MS (Sems) Zinc (Qty. 2) (232-5300-00)</small>							
<small>Item 6 is secured to Item 1 by: #8-32 X 1/4" PPH MS (Sems) Zinc (Qty. 2) (232-5300-00)</small>							

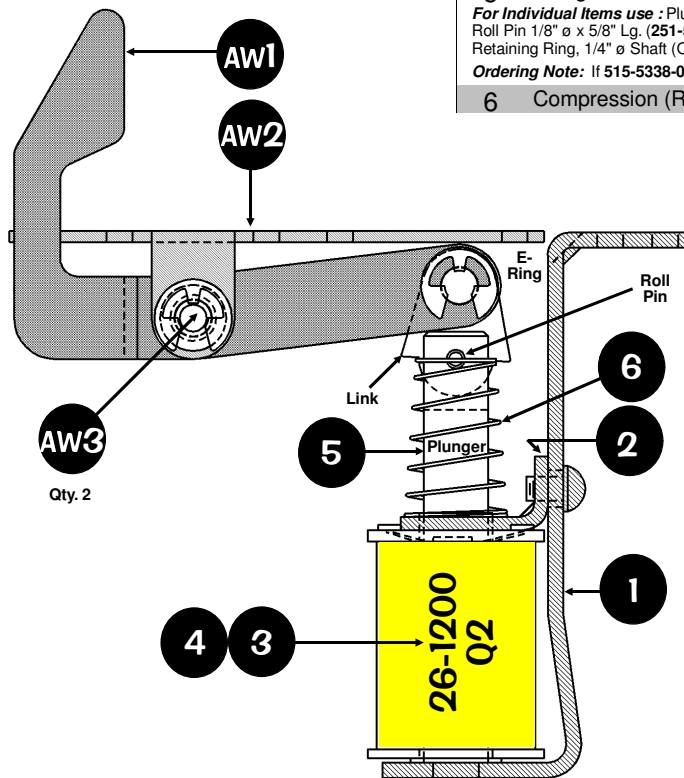

Sec. 4: Drawings ...



5-Ball Trough Assembly, 500-6318-15 (Items 1-12)

and Associated Parts: See Parts Table below.

Ordering Note: Identical to 500-6318-25 except it does not require Item 10, Trough Ball Guide Plate (used only when magnets are present in the game).

Nº	INDIVIDUAL PART NAME	QTY.	SPI PART Nº	Nº	INDIVIDUAL PART NAME	QTY.	SPI PART Nº
1	Ball Trough Outhole Mounting Bracket	1	515-6580-01	10	Trough Ball Guide Plate <i>Not Required</i>	0	535-7801-00
Item 1 is secured below the playfield by: #8 X 1/2" HWH AB (Zinc) (Qty. 6) (234-5101-00)							
2	Micro Switch (Roller Actuator, Lite-Force)	4	180-5119-02	11	Dual OPTO TRANS Board Assembly	1	515-0173-00
Item 2 is secured to Item 1 by: #2-56 X 1/2" HWH (Sr) UNS #4HD TR3 BO (Qty. 6) (237-5937-02)							
Item 2 requires: Heat Shrink Tubing 1/8" ø PUI-24 (Qty. 1"/per) (605-5006-00)							
Switch has a Diode (1N4004) (112-5003-00). Can be replaced with (1N4001) (112-5001-00).							
3	Coil Mounting Bracket	1	535-7330-01	12	Dual OPTO REC Board Assembly	1	515-0174-00
Item 3 is secured to Item 1 by: #8-32 X 3/8" HWH Swage (Sr.) Zinc (Qty. 4) (237-5975-00)							
4	Coil Retaining Bracket	1	535-5203-03	Items 11 & 12 are by: #6-32 X 5/8" HWH Swage (Serr) Zinc (Qty. 3/per) (237-5976-04)			
Item 4 is secured to Item 4 by: #8-32 X 1/4" HWH MS (Serr) Zinc (Qty. 2) (237-5964-01)							
5	Coil, 26-1200	1	090-5044-00T	For Individual Items use : Dual OPTO TRANS Bd. (Qty. 1) (520-5173-00), Dual OPTO REC Bd. (Qty. 1) (520-5174-00), OPTO PCB Tube Spacer (Brass) (Qty. 3/per) (530-5308-02) or OPTO PCB Rubber Grommet (Qty. 3/per) (545-5518-00)			
Coil has a Diode (1N4004) (112-5003-00) positioned @ top (above lugs next to windings).							
6	Coil Sleeve (Short) (Formost #10-7077)	1	545-5076-01	Ordering Note: If 500-6318-15 is unavailable, order the individual part(s) actually required. This assembly is identical to 500-6318-14 except for the quantity of Item 2 (an additional switch & diode is required to accommodate this 5-Ball Game).			
7	Plunger Assembly	1	515-5941-01	ASSOCIATED PARTS ARE NOT INCLUDED WITH THE ABOVE ASSEMBLY.			
8	Compression (Return) Spring	1	266-5020-00	Nº	ASSOCIATED PART NAME	QTY.	SPI PART Nº
9	Rubber Bumper (Grommet)	1	545-5105-00	AP-A	Ball Trough Enter / Exit Scoop	1	535-7329-01
Item AP-A secured to the playfield by: #8 X 1/2" HWH AB (Zinc) (Qty. 4) (234-5101-00).							
AP-B* Steel Balls (1-1/16" ø) 5 260-5000-00							

Take Special Note:

Item AP-A, Enter / Exit Scoop, 535-7329-01 (not included with the 5-Ball Trough Assy.), is shown how it is actually positioned over the 5-Ball Trough Assembly. It is mounted above the playfield.

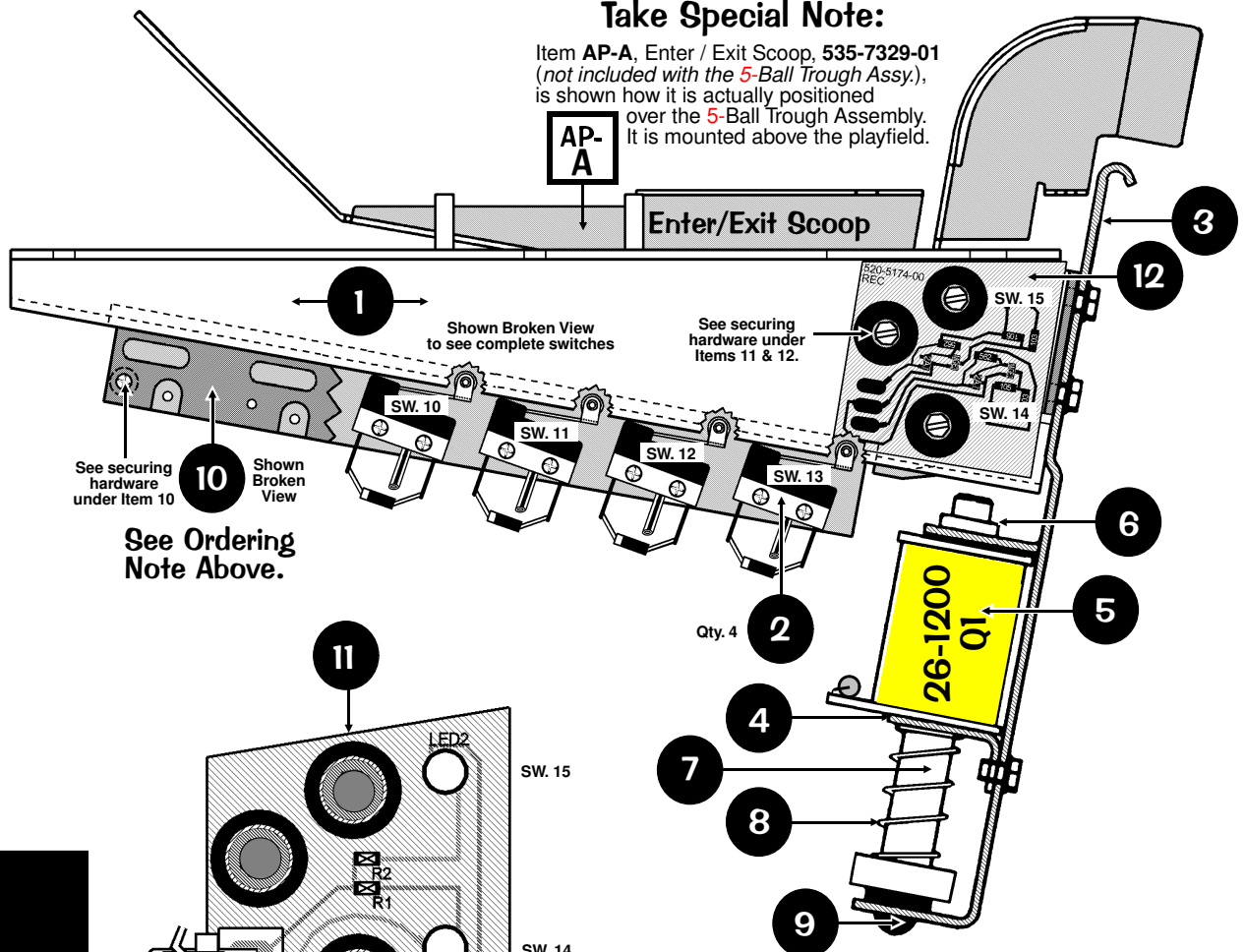

See Ordering Note Above.

Take Note:

* An asterisk (*) indicates item(s) are not noted in the pictorials.

For a break-down of parts of Items 11 & 12, OPTO Boards (515-0173-00 & 515-0174-00), see Section 5, Chapter 4, Trough Up-Kicker Dual OPTO Boards Theory of Operation & Schematic, Component Layout & Parts.



Flipper (Right) Assembly, 500-6543-02 (Items 1-15) and Assoc. Parts: Yellow Flipper Bat & Shaft Assy., 515-5133-06-06 (Item AP-A/-B)



Nº	INDIVIDUAL PART NAME	QTY.	SPI PART Nº	Nº	INDIVIDUAL PART NAME	QTY.	SPI PART Nº		
1	Flipper Base Plate (RIGHT)	1	See FRP1	13*	Crank Bar	1	530-5070-02		
Item 1 is secured below the playfield by: #10 X 1/2" HWH MS (Serr) Zinc ST (Qty. 8) (237-5949-00) Ordering Note: Use Item FRP1, see the end of this Parts Table.				Item 13 requires: Bushing, .192" ø ID X .312" ø OD X .195" (Qty. 1) (530-5139-00)					
2	Flipper Bat Bushing (White Plastic)	1	545-5070-00	14*	® Switch Actuator (RIGHT) Sub-Assy.	1	515-7257-00		
Item 2 is secured to Item 1 by: #6-32 X 3/8" HWH Swage (Ser.) Zc. (Qty. 3) (237-5976-02)				ORDERING ABOVE (ITEM 14) SUB-ASSY. PART Nº WILL INCLUDE:					
3	Power (End of Stroke) Switch	1	180-5149-00	14A	Actuator & Spring Bracket (RIGHT)	1	535-9038-00		
Item 3 is secured to Item 1 by: #6-32 X 5/8" HWH Swage (Ser.) Zc. (Qty. 2) (237-5976-04)				14B	® Switch Actuator (White Plastic)	1	545-5612-00		
4	Sw. Plate/Spring Return Brkt. (RIGHT)	1	535-7354-00	Item 14B is secured to 14A by: Rivet, 1/8" ø X 1/4" Lg. (Qty. 1) (249-5003-00)					
5	Flipper Return Spring	1	265-5035-00	15*	Set Screw: #10-32 X 3/4" Socket Hd.	2	237-6144-00		
6*	Coil Stop Bracket Sub-Assembly	1	515-6308-01	Item 15 requires: #10-32 Nylon Stop Nut (Qty. 1 Flipper Link Side Only) (240-5203-00) Tool Required for Item 15: 5/32" or 4mm Allen Wrench					
Item 6 is secured to Item 1 by: #10-32 X 3/8" SHWH Swage (Serr) Zinc (Qty. 2) (237-5985-00) and #10 Split Lock Washer (Qty. 2) (244-5003-00)				Flipper Rebuild Parts for Easier Installation, Save \$:					
7	Spring Washer (17/32" ID X 3/4" X 1")	1	269-5002-00	FRP1	Flipper Base Plate Kit (RIGHT) Includes Item 1 pre-threaded, with the Securing Hardware for Items 2, 3, 6 & 8.		515-6617-00		
8	Coil Support Bracket	1	535-7356-00	FRP2	Plunger, Link & Crank (RIGHT) Assy. Includes above Items 12, 13, 14 and 15 and is pre-assembled.		515-7203-00		
Item 8 is secured to Item 1 by: #8-32 X 3/8" HWH Swage (Ser.) Zc. (Qty. 2) (237-5975-00)				FRP3	Flipper (RIGHT) Rebuild Kit Same as FRP2, but also includes above Items 6 & 10.		500-6307-00		
9	Coil, 22-1080 (YEL-GRN) (Right)	1	090-5032-00T	ASSOCIATED PARTS ARE NOT INCLUDED WITH THE ABOVE ASSEMBLY.					
Coil has a Diode (1N4004) (112-5003-00) positioned @ top (above lugs next to windings).				Nº	ASSOCIATED PART NAME	QTY.	SPI PART Nº		
10*	Coil Sleeve	1	545-5388-00	AP-A	YELLOW Flipper Bat & Shaft (Plain) (Non-Knurled End) Assembly	1	515-5133-06-06		
11	Deflector Pad (Bumper)	1	545-5428-00	AP-B	Large Flipper RED Rubber Ring	1	545-5277-22		
12*	Flipper Plunger & Link Sub-Assy.	1	515-6304-03	ORDERING ABOVE (ITEM 12) SUB-ASSY. PART Nº WILL INCLUDE:					
Item 12B is secured to 12A by: Bushing, .16" ø ID X .281" ø OD X .187" (Qty. 1) (530-5532-00) and Spirol Pin ø 5/32" X 3/4" Lg. (Qty. 1) (251-5015-02)				12A Flipper Plunger with "Flat"				1	530-5349-01
				12B Plunger "Flipper" Link				1	545-5611-01

* To Order the Flipper (Right) Rebuild Kit ask for Part Nr.: 500-6307-00 (includes Items 6, 10, 12, 13, 14 & 15)

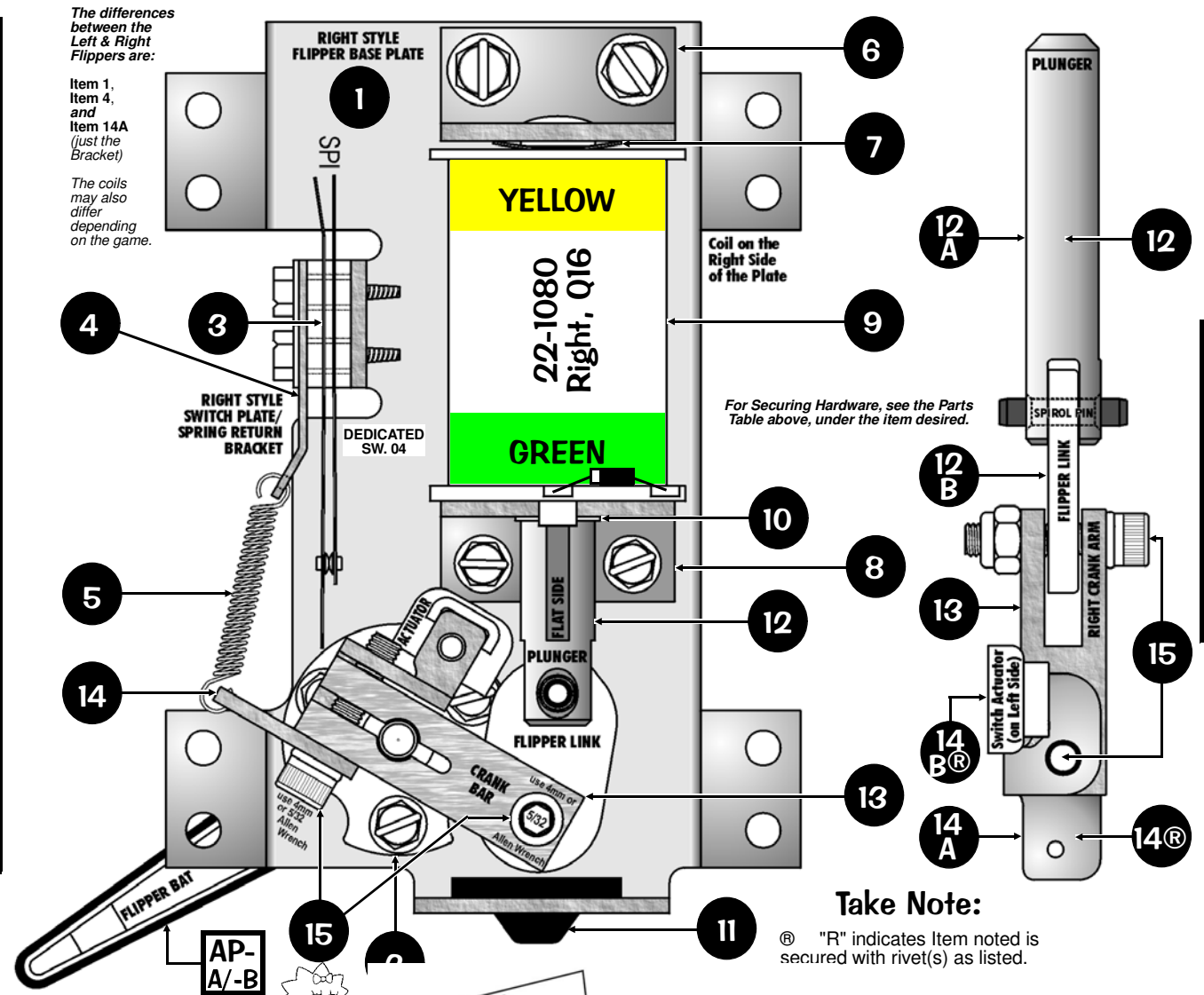

Drawings for Major Assemblies & Ramps



Take Note:
® "R" indicates Item noted is secured with rivet(s) as listed.

Sec. 4: Drawings ...

Flipper (Mini-Playfield, Left) Assembly, 500-6543-79 (Items 1-15) and Associated Parts: See Parts Table Below (Items AP-A, AP-B, AP-C & AP-D)

(Identical to 500-6543-39 except for Item 2, 545-5070-00. 500-6543-79 requires a modified Item 2, 545-5070-01)

Nº	INDIVIDUAL PART NAME	QTY.	SPI PART Nº	Nº	INDIVIDUAL PART NAME	QTY.	SPI PART Nº
1	Flipper Base Plate (LEFT)	1	See FRP1	13*	Crank Bar	1	530-5070-02
Item 1 is secured below the playfield by: #10 X 1/2" HWH MS (Serr) Zinc ST (Qty. 8) (237-5949-00) Ordering Note: Use Item FRP1, see the end of this Parts Table.				Item 13 requires: Bushing, .192" ø ID X .312" ø OD X .195" (Qty. 1) (530-5139-00)			
2	Flipper Bat Bushing (Modified)	1	545-5070-01	14*	⊗ Switch Actuator (LEFT) Sub-Assy.	1	515-7257-01
Item 2 is secured to Item 1 by: #6-32 X 3/8" HWH Swage (Ser.) Zc. (Qty. 3) (237-5976-02)				ORDERING ABOVE (ITEM 14) SUB-ASSY. PART Nº WILL INCLUDE:			
3	1/4" X 3/8" Spacer Gray	2	254-5000-02	14A	Actuator & Spring Bracket (LEFT)	1	535-9038-01
Item 3 is secured to Item 1 by: #6-32 X 5/8" HWH Sw. (Ser.) Zc. (Qty. 1/per) (237-5976-04)				14B	⊗ Switch Actuator (White Plastic)	1	545-5612-00
4	Sw. Plate/Spring Return Brkt. (LEFT)	1	535-7354-01	Item 14B is secured to 14A by: Rivet, 1/8" ø X 1/4" Lg. (Qty. 1) (249-5003-00)			
5	Flipper Return Spring	1	265-5035-00	15*	Set Screw: #10-32 X 3/4" Socket Hd.	2	237-6144-00
6*	Coil Stop Bracket Sub-Assembly	1	515-6308-01	Item 15 requires: #10-32 Nylon Stop Nut (Qty. 1 Flipper Link Side Only) (240-5203-00)			
Item 6 is secured to Item 1 by: #10-32 X 3/8" SHWH Swage (Serr) Zinc (Qty. 2) (237-5985-00) and #10 Split Lock Washer (Qty. 2) (244-5003-00)				Tool Required for Item 15: 5/32" or 4mm Allen Wrench			
7	Spring Washer (17/32" ID X 3/4" X 1")	1	269-5002-00	Flipper Rebuild Parts for Easier Installation, Save \$:			
8	Coil Support Bracket	1	535-7356-00	FRP1 Flipper Base Plate Kit (LEFT)			
Item 8 is secured to Item 1 by: #8-32 X 3/8" HWH Swage (Ser.) Zc. (Qty. 2) (237-5975-00)				FRP1 Includes Item 1 pre-threaded, with the Securing Hardware for Items 2, 3, 6 & 8. 515-6617-01			
9	Coil, 25-1800 (BLU-GRN) (2nd P/F Upper Left)	1	090-5041-00T	FRP2 Plunger, Link & Crank (LEFT) Assy.			
Coil has a Diode (1N4004) (112-5003-00) positioned @ top (above lugs next to windings).				FRP2 Includes above Items 12, 13, 14 and 15 and is pre-assembled. 515-7203-01			
10*	Coil Sleeve	1	545-5388-00	FRP3 Flipper (LEFT) Rebuild Kit			
11	Deflector Pad (Bumper)	1	545-5428-00	FRP3 Same as FRP2, but also includes above Items 6 & 10. 500-6307-10			
12*	Flipper Plunger & Link Sub-Assy.	1	515-6304-03	ASSOCIATED PARTS ARE NOT INCLUDED WITH THE ABOVE ASSEMBLY.			
ORDERING ABOVE (ITEM 12) SUB-ASSY. PART Nº WILL INCLUDE:				Nº ASSOCIATED PART NAME QTY. SPI PART Nº			
12A	Flipper Plunger with "Flat"	1	530-5349-01	AP-A	YELLOW Mini-Flipper Bat & 6" Shaft	1	515-7265-06
12B	Plunger "Flipper" Link	1	545-5611-01	AP-B	Small Flipper RED Rubber Ring	1	545-5207-22
Item 12B is secured to 12A by: Bushing, .16" ø ID X .281" ø OD X .187" (Qty. 1) (530-5532-00) and Spirol Pin ø 5/32" X 3/4" Lg. (Qty. 1) (251-5015-02)				AP-C	Spacer, WHT 1/4" ID x 1" w x 16mm H	1	530-5633-00

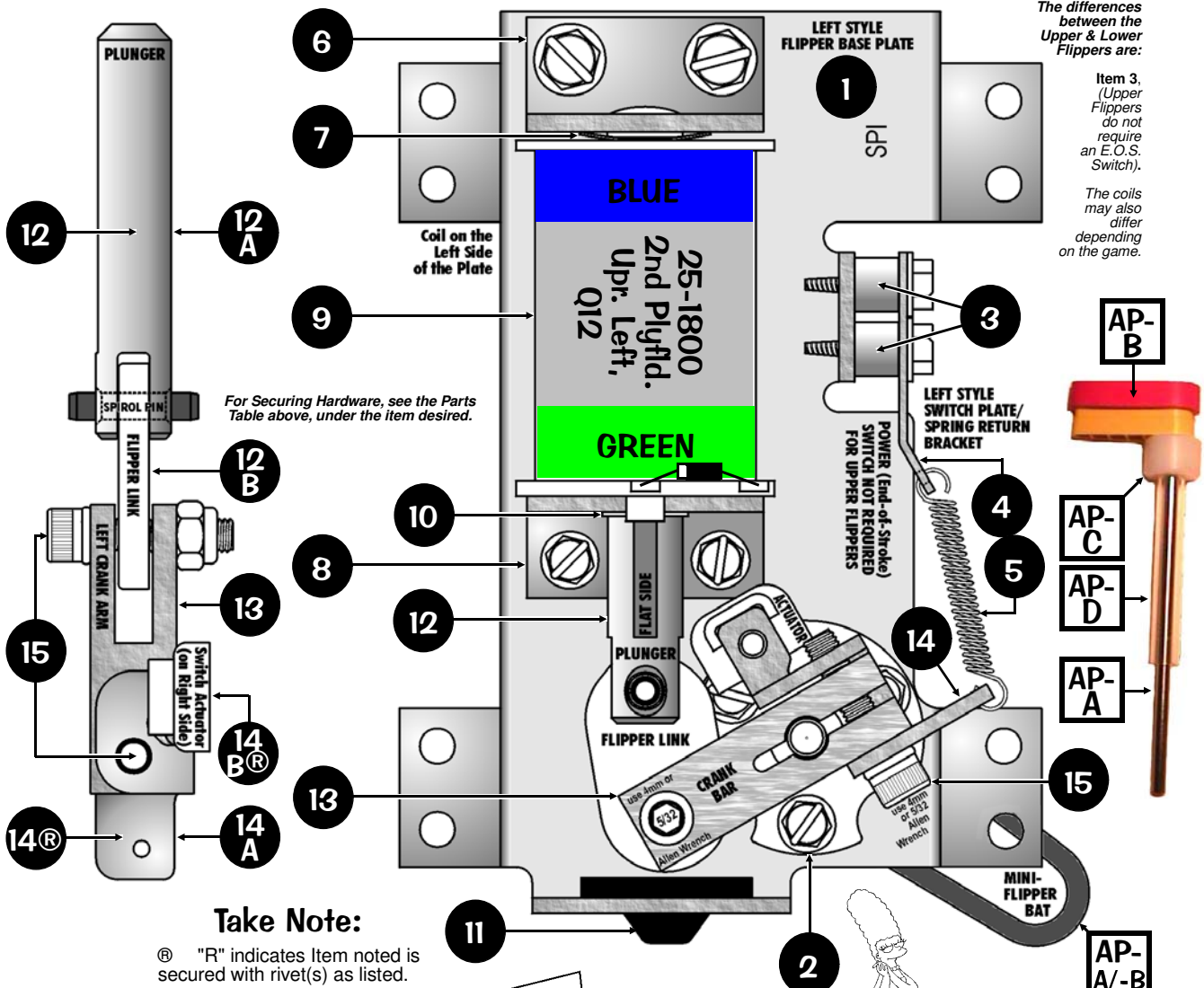

Sec. 4: Drawings ...

Take Note:

® "R" indicates Item noted is secured with rivet(s) as listed.

* To Order the Flipper (Left) Rebuild Kit ask for Part Nr.: 500-6307-10 (includes Items 6, 10, 12, 13, 14 & 15)



Flipper (Mini-Playfield, Right) Assembly, 500-6543-66 (Items 1-15) and Associated Parts: See Parts Table Below (Items AP-A, AP-B, AP-C & AP-D)

(Identical to 500-6543-26 except for Item 2, 545-5070-00. 500-6543-66 requires a modified Item 2, 545-5070-01)

Nº	INDIVIDUAL PART NAME	QTY.	SPI PART Nº	Nº	INDIVIDUAL PART NAME	QTY.	SPI PART Nº
1	Flipper Base Plate (RIGHT)	1	See FRP1	13*	Crank Bar	1	530-5070-02
Item 1 is secured below the playfield by: #10 X 1/2" HWH MS (Serr) Zinc ST (Qty. 8) (237-5949-00) Ordering Note: Use Item FRP1, see the end of this Parts Table.							
2	Flipper Bat Bushing (Modified)	1	545-5070-01	14*	® Switch Actuator (RIGHT) Sub-Assy.	1	515-7257-00
Item 2 is secured to Item 1 by: #6-32 X 3/8" HWH Swage (Ser.) Zc. (Qty. 3) (237-5976-02)							
3	1/4" X 3/8" Spacer Gray	2	254-5000-02	ORDERING ABOVE (ITEM 14) SUB-ASSY. PART Nº WILL INCLUDE:			
Item 3 is secured to Item 1 by: #6-32 X 5/8" HWH Sw. (Ser.) Zc. (Qty. 1/per) (237-5976-04)							
4	Sw. Plate/Spring Return Brkt. (RIGHT)	1	535-7354-00	14A	Actuator & Spring Bracket (RIGHT)	1	535-9038-00
5	Flipper Return Spring	1	265-5035-00	14B	® Switch Actuator (White Plastic)	1	545-5612-00
6*	Coil Stop Bracket Sub-Assembly	1	515-6308-01	Item 14B is secured to 14A by: Rivet, 1/8" ø X 1/4" Lg. (Qty. 1) (249-5003-00)			
Item 6 is secured to Item 1 by: #10-32 X 3/8" SHWH Swage (Serr) Zinc (Qty. 2) (237-5985-00) and #10 Split Lock Washer (Qty. 2) (244-5003-00)							
7	Spring Washer (17/32" ID X 3/4" X 1")	1	269-5002-00	15*	Set Screw: #10-32 X 3/4" Socket Hd.	2	237-6144-00
8	Coil Support Bracket	1	535-7356-00	Item 15 requires: #10-32 Nylon Stop Nut (Qty. 1 Flipper Link Side Only) (240-5203-00)			
Item 8 is secured to Item 1 by: #8-32 X 3/8" HWH Swage (Ser.) Zc. (Qty. 2) (237-5975-00)							
9	Coil, 24-1570 (BLU-BLU) (2nd P/F Upr. Rt.)	1	090-5025-00T	Tool Required for Item 15: 5/32" or 4mm Allen Wrench			
Coil has a Diode (1N4004) (112-5003-00) positioned @ top (above lugs next to windings).							
10*	Coil Sleeve	1	545-5388-00	Flipper Rebuild Parts for Easier Installation, Save \$:			
11	Deflector Pad (Bumper)	1	545-5428-00	FRP1	Flipper Base Plate Kit (RIGHT)		
12*	Flipper Plunger & Link Sub-Assy.	1	515-6304-03	Includes Item 1 pre-threaded, with the Securing Hardware for Items 2, 3, 6 & 8.			
ORDERING ABOVE (ITEM 12) SUB-ASSY. PART Nº WILL INCLUDE:							
12A	Flipper Plunger with "Flat"	1	530-5349-01	FRP2	Plunger, Link & Crank (RIGHT) Assy.		
12B	Plunger "Flipper" Link	1	545-5611-01	Includes above Items 12, 13, 14 and 15 and is pre-assembled.			
Item 12B is secured to 12A by: Bushing, .16" ø ID X .281" ø OD X .187" (Qty. 1) (530-5532-00) and Spirol Pin ø 5/32" X 3/4" Lg. (Qty. 1) (251-5015-02)							
FRP3 Flipper (RIGHT) Rebuild Kit							
Same as FRP2, but also includes above Items 6 & 10.							
ASSOCIATED PARTS ARE NOT INCLUDED WITH THE ABOVE ASSEMBLY.							
Nº	ASSOCIATED PART NAME	QTY.	SPI PART Nº				
AP-A	YELLOW Mini-Flipper Bat & 6" Shaft	1	515-7265-06				
AP-B	Small Flipper RED Rubber Ring	1	545-5207-22				
AP-C	Spacer, WHT 1/4" ID x 1" w x 16mm H	1	530-5633-00				

* To Order the Flipper (Right) Rebuild Kit ask for Part Nr.: 500-6307-00 (includes Items 6, 10, 12, 13, 14 & 15)

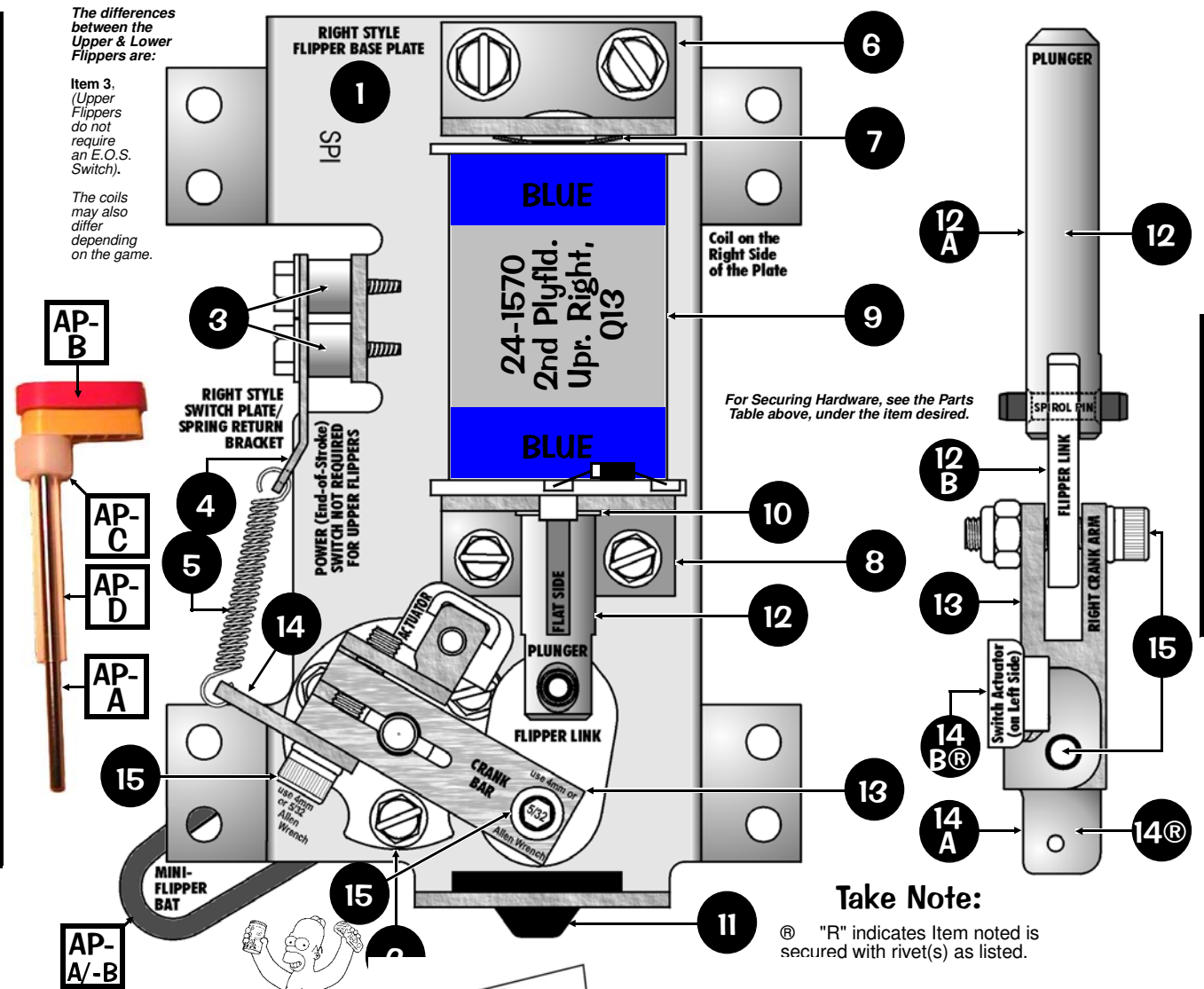

Drawings for Major Assemblies & Ramps



Sec. 4: Drawings ...

Flipper (Mid. Playfield, Upr. Right) Assembly, 500-6543-24 (Items 1-15) and Assoc. Part: Yellow Flipper Bat & Shaft Assy., 515-5133-06-06 (Items AP-A/-B)



Nº	INDIVIDUAL PART NAME	QTY.	SPI PART Nº	Nº	INDIVIDUAL PART NAME	QTY.	SPI PART Nº
1	Flipper Base Plate (RIGHT)	1	See FRP1	13*	Crank Bar	1	530-5070-02
Item 1 is secured below the playfield by: #10 X 1/2" HWH MS (Serr) Zinc ST (Qty. 8) (237-5949-00) Ordering Note: Use Item FRP1, see the end of this Parts Table.							
2	Flipper Bat Bushing (White Plastic)	1	545-5070-00	14*	Ⓜ Switch Actuator (RIGHT) Sub-Assy.	1	515-7257-00
Item 2 is secured to Item 1 by: #6-32 X 3/8" HWH Swage (Ser.) Zc. (Qty. 3) (237-5976-02)							
3	1/4" X 3/8" Spacer Gray	2	254-5000-02	ORDERING ABOVE (ITEM 14) SUB-ASSY. PART Nº WILL INCLUDE:			
Item 3 is secured to Item 1 by: #6-32 X 5/8" HWH Sw. (Ser.) Zc. (Qty. 1/per) (237-5976-04)							
4	Sw. Plate/Spring Return Brkt. (RIGHT)	1	535-7354-00	14A	Actuator & Spring Bracket (RIGHT)	1	535-9038-00
5	Flipper Return Spring	1	265-5035-00	14B	Ⓜ Switch Actuator (White Plastic)	1	545-5612-00
6*	Coil Stop Bracket Sub-Assembly	1	515-6308-01	Item 14B is secured to 14A by: Rivet, 1/8" ø X 1/4" Lg. (Qty. 1) (249-5003-00)			
Item 6 is secured to Item 1 by: #10-32 X 3/8" SHWH Swage (Serr) Zinc (Qty. 2) (237-5985-00) and #10 Split Lock Washer (Qty. 2) (244-5003-00)							
7	Spring Washer (17/32" ID X 3/4" X 1")	1	269-5002-00	15*	Set Screw: #10-32 X 3/4" Socket Hd.	2	237-6144-00
8	Coil Support Bracket	1	535-7356-00	Item 15 requires: #10-32 Nylon Stop Nut (Qty. 1 Flipper Link Side Only) (240-5203-00)			
Item 8 is secured to Item 1 by: #8-32 X 3/8" HWH Swage (Ser.) Zc. (Qty. 2) (237-5975-00)							
9	Coil, 23-1100 (ORG-ORG) (Mid. Upr. Rt.)	1	090-5030-00T	Tool Required for Item 15: 5/32" or 4mm Allen Wrench			
Coil has a Diode (1N4004) (112-5003-00) positioned @ top (above lugs next to windings).							
10*	Coil Sleeve	1	545-5388-00	Flipper Rebuild Parts for Easier Installation, Save \$:			
11	Deflector Pad (Bumper)	1	545-5428-00	FRP1	Flipper Base Plate Kit (RIGHT)		515-6617-00
12*	Flipper Plunger & Link Sub-Assy.	1	515-6304-03	Includes Item 1 pre-threaded, with the Securing Hardware for Items 2, 3, 6 & 8.			
ORDERING ABOVE (ITEM 12) SUB-ASSY. PART Nº WILL INCLUDE:							
12A	Flipper Plunger with "Flat"	1	530-5349-01	FRP2	Plunger, Link & Crank (RIGHT) Assy.		515-7203-00
12B	Plunger "Flipper" Link	1	545-5611-01	Includes above Items 12, 13, 14 and 15 and is pre-assembled.			
Item 12B is secured to 12A by: Bushing, .16" ø ID X .281" ø OD X .187" (Qty. 1) (530-5532-00) and Spirol Pin ø 5/32" X 3/4" Lg. (Qty. 1) (251-5015-02)							
FRP3 Same as FRP2, but also includes above Items 6 & 10. 500-6307-00							
ASSOCIATED PARTS ARE NOT INCLUDED WITH THE ABOVE ASSEMBLY.							
Nº	ASSOCIATED PART NAME	QTY.	SPI PART Nº				
AP-A	YELLOW Flipper Bat & Shaft (Plain) (Non-Knurled End) Assembly	1	515-5133-06-06				
AP-B	Large Flipper RED Rubber Ring	1	545-5277-22				

The differences between the Upper & Lower Flippers are:

Item 3, (Upper Flippers do not require an E.O.S. Switch).

The coils may also differ depending on the game.

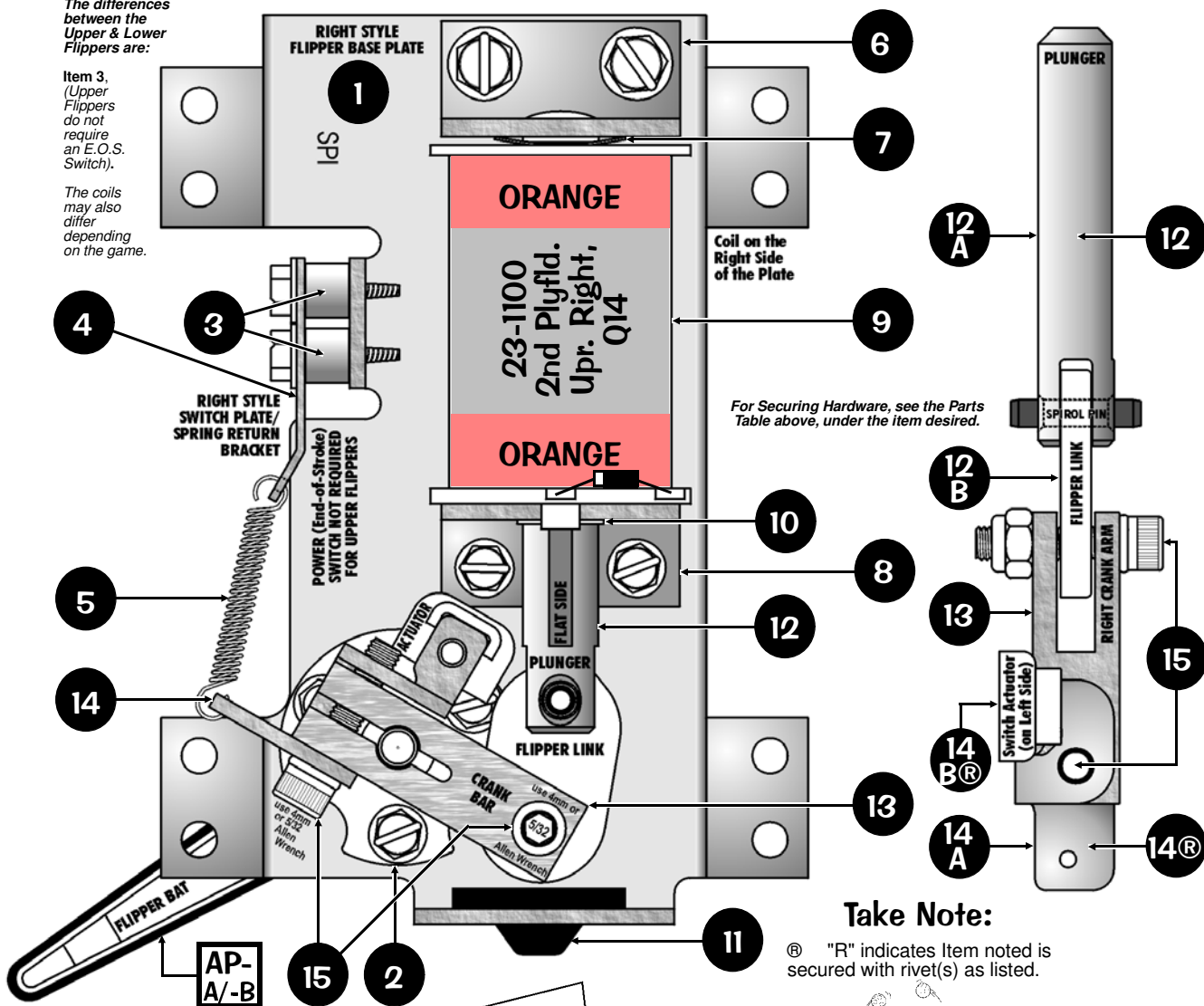

* To Order the Flipper (Right) Rebuild Kit ask for Part Nr.: 500-6307-00 (includes Items 6, 10, 12, 13, 14 & 15)

Take Note:

Ⓜ "R" indicates Item noted is secured with rivet(s) as listed.

Sec. 4: Drawings ...



**Bumper Top Assemblies, 515-6459-01 (Qty. 3) (Items 1-7),
Bumper Bottom Assy., 515-6459-04 (Qty. 3) (Items 8-15),
Bumper Switch Assy., 515-6459-03 (Qty. 3) (Items 16-19)
and Associated Part(s): See Parts Table below.**

For Securing Hardware, see the Parts Table below, under the item desired.

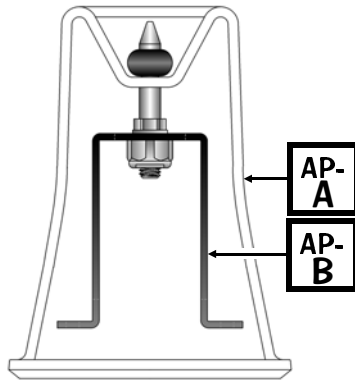

Note in this Pinball Machine only:
In lieu of Bumper Caps, the **Right & Bottom Bumper Top Assemblies** have plastic "Nuclear Cooling Towers" affixed to them. The **Left Bumper** is under a Screened Plastic Piece (-20)*. See the **Associated Parts** at the bottom of this page.

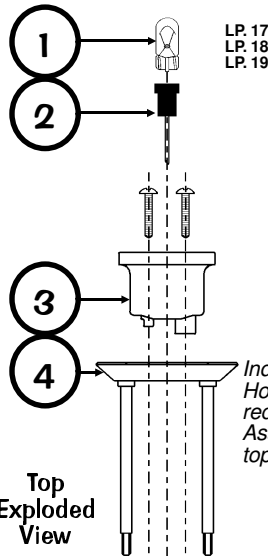

Top Exploded View

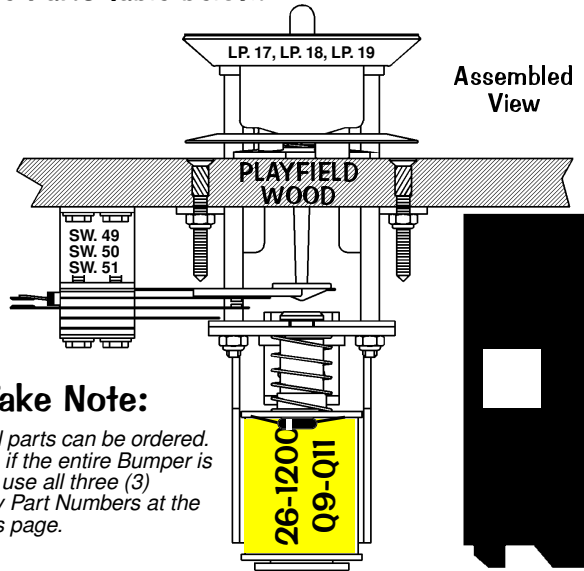

Assembled View

Take Note:

Individual parts can be ordered. However, if the entire Bumper is required, use all three (3) Assembly Part Numbers at the top of this page.

Nº	BUMPER TOP PART NAME	QTY.	SPI PART Nº
1	#555 Wedge Base Bulb	1	165-5002-00
2	Wedge Base Socket	1	077-5206-00
3	Bumper Body	1	545-5197-00
Item 3 is secured by: #5 X 7/8" PRH AB (Zinc) (Qty. 2) (237-5826-00)			
4	Ring Assembly	1	515-5085-00
Item 4 is secured by: #6-32 Nylon Stop Nut (Qty. 2) (240-5005-00)			
5	Bumper Skirt	1	545-5607-00
6	Bumper Skirt Compression Spring	1	266-5048-00
7	Bumper Base	1	545-5195-00

Nº	BUMPER BOTTOM PART NAME	QTY.	SPI PART Nº
8	Plunger	1	530-5348-00
9	Compression (Return) Spring	1	266-5047-00
10	Coil, 26-1200	1	090-5044-00T
Coil has a Diode (1N4004) (112-5003-00) positioned @ top (above lugs next to windings).			
11	Coil Sleeve	1	545-5031-00
12	Fiber Yoke	1	545-5609-00
13	Metal Yoke	1	535-7346-00
14	Metal Yoke Stop	1	535-7347-00
Item 14 is secured by: #6-32 X 1/4" HWH Swage (Serr.) Zinc (Qty. 2) (237-5976-01)			
15	Coil Bracket Welded Assembly	1	515-5939-00
Item 15 is secured by: #6-32 X 1-3/16" Spiral Fin Shank (Qty. 3) (237-5957-00) and #6-32 Nylon Stop Nut (Qty. 3) (240-5005-00)			

Nº	BUMPER SWITCH PART NAME	QTY.	SPI PART Nº
16	Switch Bracket	1	535-7342-00
Item 16 is secured by: #8 X 1/2" HWH AB (Zinc) (Qty. 2) (234-5101-00)			
17	Spoon Switch Actuator	1	545-5610-01
18	Bumper Stack (Blade) Switch	1	180-5015-03
Switch has a Diode (1N4004) (112-5003-00). Can be replaced with (1N4001) (112-5001-00).			
19	Switch Body Protect Plate	1	535-7344-00
Items 18 & 19 are secured by: #6-32 X 3/4" HWH Swage (Serr.) Zc. (Qty. 2) (237-5976-05)			

The Top & Bottom Assemblies are secured together by hardware included in assemblies.

ASSOCIATED PART IS NOT INCLUDED WITH THE ABOVE ASSEMBLY.

Nº	ASSOCIATED PART NAME	QTY.	SPI PART Nº
AP-A	Nuclear Cooling Tower (Plastic)	2	545-6065-25
Item AP-A is secured to Item AP-B by: Mini-Post MS/#10-32 Post (Qty. 1/per) (530-5005-01), #10-32 Nylon Stop Nut (Qty. 1/per) (240-5203-00) and 7/16" O.D. Rubber Ring, Black (Qty. 1/per) (545-5348-17) Push down on Tower to place Rubber on Post.			
AP-B	Mounting Bracket (Black)	2	535-9200-00
Item AP-B is secured to Item 3 by: #4-40 X 3/8" HWH MS (Zinc) TF (Qty. 2/per) (237-5933-00)			

Kit: Plastics (Screened & Clear) 1 803-5000-77
Kit: Game Specific Decals 1 802-5000-77
Note: For associated Plastics (-16, -18 & -20) or Decals (-10 Qty. 3/per), see **Main Playfield & Mini-Playfield - Plastics (Screened & Clear) & Decals, Page 67.**
 Plastic Pieces & Game Decals are not available individually, ordering of either kit is required.

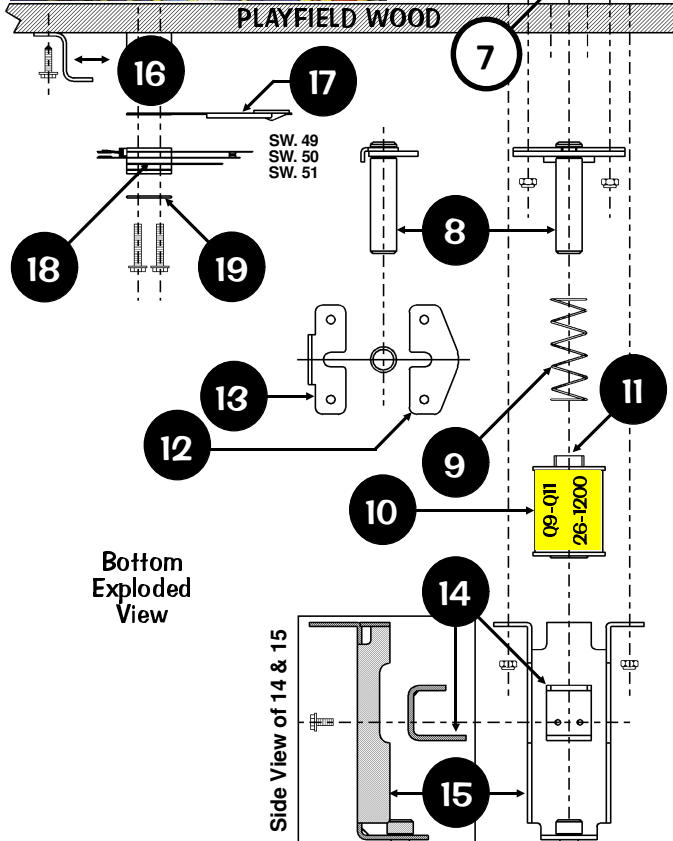

Bottom Exploded View

Side View of 14 & 15

Sec. 4: Drawings ...





Homer Head Actuator (Upr. Rt. Flipper Style) Assembly, 500-6543-21 (Items 1-15)

Works in conjunction with the Homer Head Assembly on the next page.

Nº	INDIVIDUAL PART NAME	QTY.	SPI PART Nº	Nº	INDIVIDUAL PART NAME	QTY.	SPI PART Nº
1	Flipper Base Plate (RIGHT)	1	See FRP1	13*	Crank Bar	1	530-5070-02
Item 1 is secured below the playfield by: #10 X 1/2" HWH MS (Serr) Zinc ST (Qty. 6) (237-5949-00) Ordering Note: Use Item FRP1, see the end of this Parts Table.							
2	Flipper Bat Bushing (White Plastic)	1	545-5070-00	14*	Ⓜ Switch Actuator (RIGHT) Sub-Assy.	1	515-7257-00
Item 2 is secured to Item 1 by: #6-32 X 3/8" HWH Swage (Ser.) Zc. (Qty. 3) (237-5976-02)							
3	1/4" X 3/8" Spacer Gray	2	254-5000-02	ORDERING ABOVE (ITEM 14) SUB-ASSY. PART Nº WILL INCLUDE:			
Item 3 is secured to Item 1 by: #6-32 X 5/8" HWH Sw. (Ser.) Zc. (Qty. 1/per) (237-5976-04)							
4	Sw. Plate/Spring Return Brkt. (RIGHT)	1	535-7354-00	14A	Actuator & Spring Bracket (RIGHT)	1	535-9038-00
5	Flipper Return Spring	1	265-5035-00	14B	Ⓜ Switch Actuator (White Plastic)	1	545-5612-00
6*	Coil Stop Bracket Sub-Assembly	1	515-6308-01	Item 14B is secured to 14A by: Rivet, 1/8" ø X 1/4" Lg. (Qty. 1) (249-5003-00)			
Item 6 is secured to Item 1 by: #10-32 X 3/8" SHWH Swage (Serr) Zinc (Qty. 2) (237-5985-00) and #10 Split Lock Washer (Qty. 2) (244-5003-00)							
7	Spring Washer (17/32" ID X 3/4" X 1")	1	269-5002-00	15*	Set Screw: #10-32 X 3/4" Socket Hd.	2	237-6144-00
8	Coil Support Bracket	1	535-7356-00	Item 15 requires: #10-32 Nylon Stop Nut (Qty. 1 Flipper Link Side Only) (240-5203-00)			
Item 8 is secured to Item 1 by: #8-32 X 3/8" HWH Swage (Ser.) Zc. (Qty. 2) (237-5975-00)							
9	Coil, 22-900 (YEL-YEL)	1	090-5020-20T	Tool Required for Item 15: 5/32" or 4mm Allen Wrench			
Coil has a Diode (1N4004) (112-5003-00) positioned @ top (above lugs next to windings).							
10*	Coil Sleeve	1	545-5388-00	Flipper Rebuild Parts for Easier Installation, Save \$:			
11	Deflector Pad (Bumper)	1	545-5428-00	FRP1 Flipper Base Plate Kit (RIGHT)			
12*	Flipper Plunger & Link Sub-Assy.	1	515-6304-03	Includes Item 1 pre-threaded, with the Securing Hardware for Items 2, 3, 6 & 8. 515-6617-00			
ORDERING ABOVE (ITEM 12) SUB-ASSY. PART Nº WILL INCLUDE:							
12A	Flipper Plunger with "Flat"	1	530-5349-01	FRP2 Plunger, Link & Crank (RIGHT) Assy.			
12B	Plunger "Flipper" Link	1	545-5611-01	Includes above Items 12, 13, 14 and 15 and is pre-assembled. 515-7203-00			
Item 12B is secured to 12A by: Bushing, .16" ø ID X .281" ø OD X .187" (Qty. 1) (530-5532-00) and Spirol Pin ø 5/32" X 3/4" Lg. (Qty. 1) (251-5015-02)							

Take Note:

Ⓜ "R" indicates Item noted is secured with rivet(s) as listed.

The differences between the Upper & Lower Flippers are:

Item 3, (Upper Flippers do not require an E.O.S. Switch).

The coils may also differ depending on the game.

Sec. 4: Drawings ...

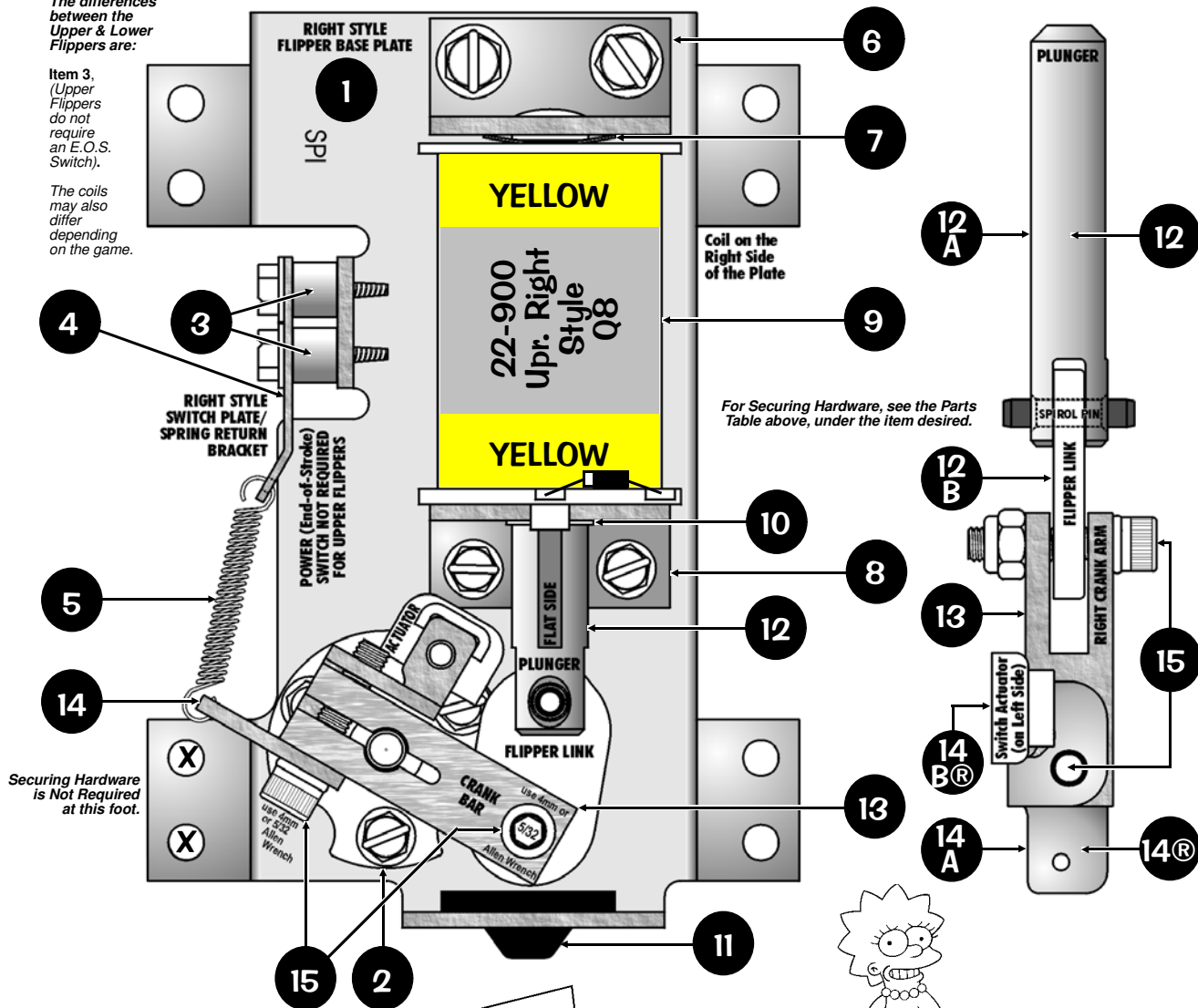

* To Order the Flipper (Right) Rebuild Kit ask for Part Nr.: 500-6307-00 (includes Items 6, 10, 12, 13, 14 & 15)



Homer Head Assembly Individual Parts Only (Items 1-7)

Works in conjunction with the "Upper Right Style" Flipper Assembly on the previous page.

Nº	INDIVIDUAL PART NAME	QTY.	SPI PART Nº	Nº	INDIVIDUAL PART NAME	QTY.	SPI PART Nº
1	Homer Head (Modified)	1	880-5057-01	4	Wire Bracket (<i>Socket to Shaft Mount</i>)	1	535-9199-00
Item 1 is secured onto Item 2 by: Rubber Ring, 3/16" I.D. (Black) (Qty. 1) (545-5348-01). Note the notch in Homer's neck should be positioned correctly onto Item 3. Take Care when removing the Homer Head so damage to Item 6 (Bulb) does not occur.				Item 4 is secured to Item 4 (@ top) by: #2-56 X 1/2" HWH Ser Uns #4HD TR3 Black (Qty. 1) (237-5937-02) and #2-56 Nylon Stop Nut (Qty. 1) (240-5321-00) Item 4 is secured above the Playfield by: #6 X 3/8" HWH AB (Zinc) (Qty. 1) (234-5000-00)			
2	Pivot Shaft (Black)	1	530-5632-00	5	Wedge Base Socket	1	077-5206-00
3	Hanger Plate	1	535-9198-00	If replacing Item 5, redress wires along Item 4 with 4" Cable Ties (040-5001-01).			
Item 3 is secured onto Item 2 (@ bottom) by: Retaining Ring (E-Ring), 3/8" ø (Qty. 1) (270-5012-00) and Rubber Ring, 3/8" I.D. (Black) (Qty. 1) (545-5348-03)				6	#906 Wedge Base Bulb (Clear)	1	165-5004-00
				7	Rubber Ring, Black 2" I.D.	1	545-5348-08

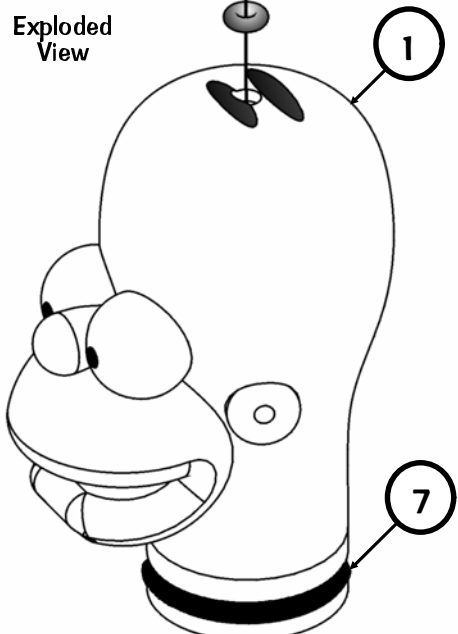
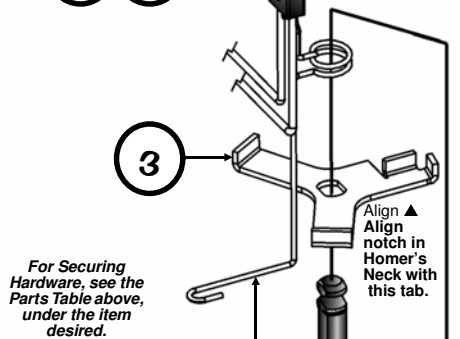
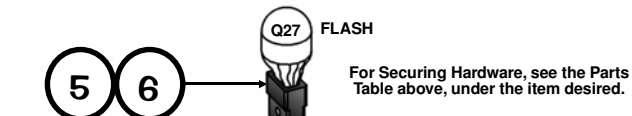

Assembled View ▼

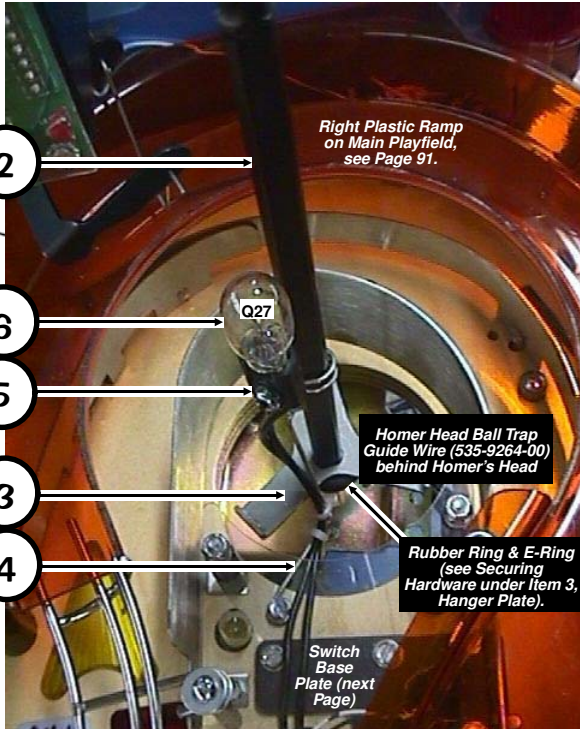
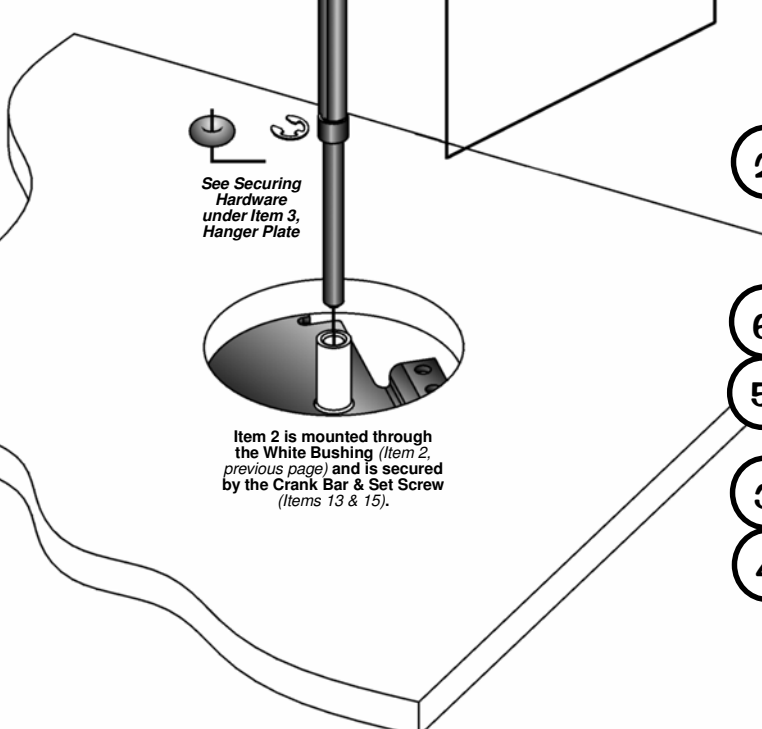

Sec. 4: Drawings ...

Slingshot Assemblies, 500-5849-00 (Qty. 2) (Items 1-9)

Nº	INDIVIDUAL PART NAME	QTY.	SPI PART Nº
1	Slingshot Bracket Assembly	1	515-5339-01
Item 1 is secured below the playfield by: #8 X 1/2" HWH AB (Zinc) (Qty. 3) (234-5101-00)			
2	Coil Retaining Bracket	1	535-5203-03
Item 2 is secured to Item 1 by: #8-32 X 3/8" PPH MS (Sems) (Qty. 2) (232-5301-00)			
3	Coil, 23-800	1	090-5001-00T
Coil has a Diode (1N4004) (112-5003-00) positioned @ top (above lugs next to windings).			
4	Coil Sleeve	1	545-5031-00
5	Plunger & Link Assembly	1	515-5338-00
For Individual Items use : Plunger 2" Lg. (530-5025-01), Plunger Link (545-5293-00) and Roll Pin 1/8" ø x 5/8" Lg. (251-5008-00) The Plunger Link is secured to the Riveted Arm by: Retaining Ring, 1/4" ø Shaft (Qty. 1) (270-5002-00)			
Ordering Note: If 515-5338-00 is unavailable, order the individual part(s) actually required.			
6	Compression (Return) Spring	1	266-5020-00
7	Slingshot Stack (Blade) Switch	2	180-5054-00
Switch has a Diode (1N4004) (112-5003-00). Can be replaced with (1N4001) (112-5001-00).			
8	Switch Body Protect Plate	2	535-5045-00
Items 7 & 8 are secured to Item 1 by: #6-32 X 5/8" HWH Swage (Qty. 4) (237-5976-04)			
9®	Riveted Arm & Tip Assembly	1	515-5340-01
For Individual Parts use (requires drilling out rivet & re-venting) : Arm (515-5341-01), Kicker Tip (545-5216-01) and Rivet, 1/8" ø x 1/4" Lg. (249-5003-00) The Riv. Arm is secured to Item 1 by: Retaining Ring, 1/4" ø Shaft (Qty. 1) (270-5002-00)			
Ordering Note: If 515-5340-01 is unavailable, order the individual part(s) actually required.			

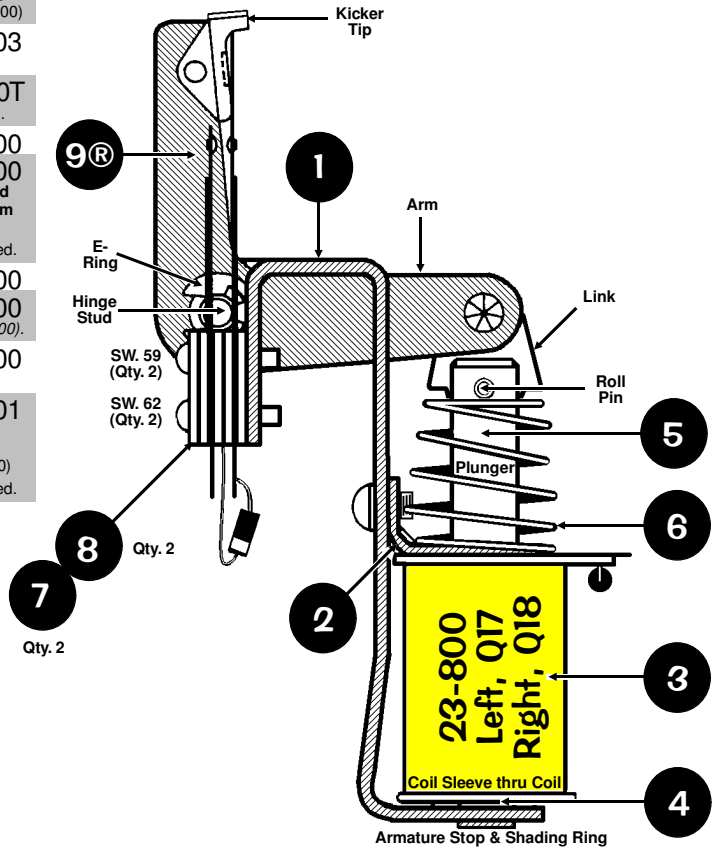

Take Note:

- * An asterisk (*) indicates item(s) are not noted in the pictorials.
- ® "R" indicates Item noted is secured with rivet(s) as listed.

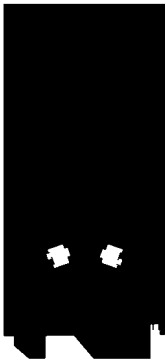

30° Eject Assembly, 500-6511-11 (Items 1-8)

and Associated Parts: Switch & Bracket Individual Parts (Items AP-A, AP-B & AP-C)

Sec. 4: Drawings ...

Nº	INDIVIDUAL PART NAME	QTY.	SPI PART Nº
1	Mounting Bracket 30° Bend (Frame)	1	535-8932-00
Item 1 is secured below the playfield by: #8 X 1/2" HWH AB (Zinc) (Qty. 2) (234-5101-00)			
2	Coil Retaining Bracket	1	535-5203-03
Item 2 is secured to Item 1 by: #8-32 X 1/4" PPH MS (Sems) (Qty. 2) (232-5300-00)			
3	Coil, 26-1200	1	090-5044-00T
Coil has a Diode (1N4004) (112-5003-00) positioned @ top (above lugs next to windings).			
4	Coil Sleeve (Short) (Formost #10-7077)	1	545-5076-01
5	Spring Washer (17/32" ID X 3/4" X 1")	1	269-5002-00
6	Plunger Assembly	1	515-7197-00
7	Compression (Return) Spring	1	266-5022-01
8	Rubber Bumper (Grommet)	1	545-5105-00

Ordering Note: If 500-6511-11 is unavailable, order the individual part(s) actually required. This assembly is identical to 500-6511-00 except for Item 3 (replace with above referenced part number for the different Coil) and Item 7 (replace with above referenced part number for the different Compression Spring).

ASSOCIATED PART IS NOT INCLUDED WITH THE ABOVE ASSEMBLY.

Nº	ASSOCIATED PART NAME	QTY.	SPI PART Nº
AP-A	Switch Base Plate (Black)	1	535-9195-00
AP-B	Switch Mounting Bracket	2	535-9194-00
AP-C	Micro Switch (Roller Actuator, Lite-Force)	1	180-5119-02
Switch has a Diode (1N4004) (112-5003-00). Can be replaced with (1N4001) (112-5001-00).			
Item AP-A is secured >above< the Playfield by: #8 X 1/2" HWH AB (Zinc) (Qty. 2) (234-5101-00)			
Item AP-C is secured to Items AP-A & AP-B by: #6-32 X 5/8" HWH Swage (Serr) Zinc (Qty. 2) (237-5976-04)			

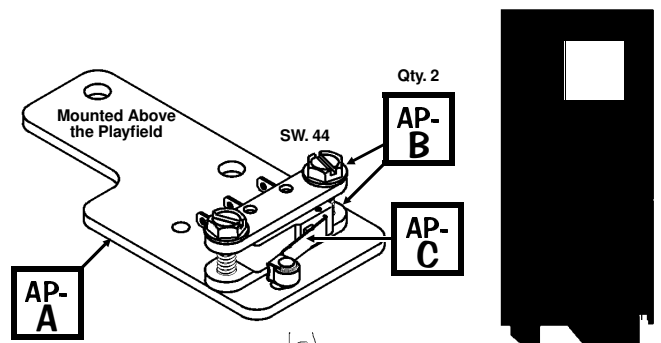
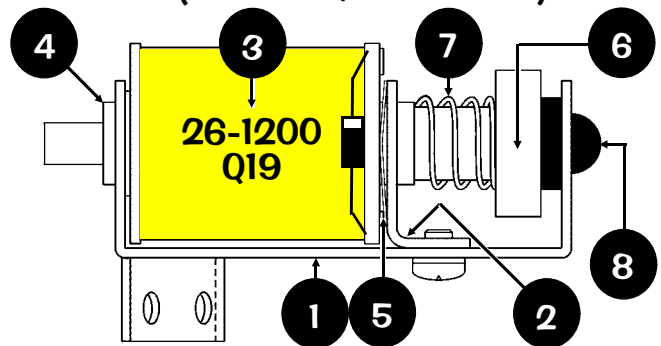

VUK (Vertical Up-Kicker, Right Style) Assembly, 500-6659-00 (Items 1-12)

Located behind the 3-Bank Drop Target, launches ball back into play after entry.

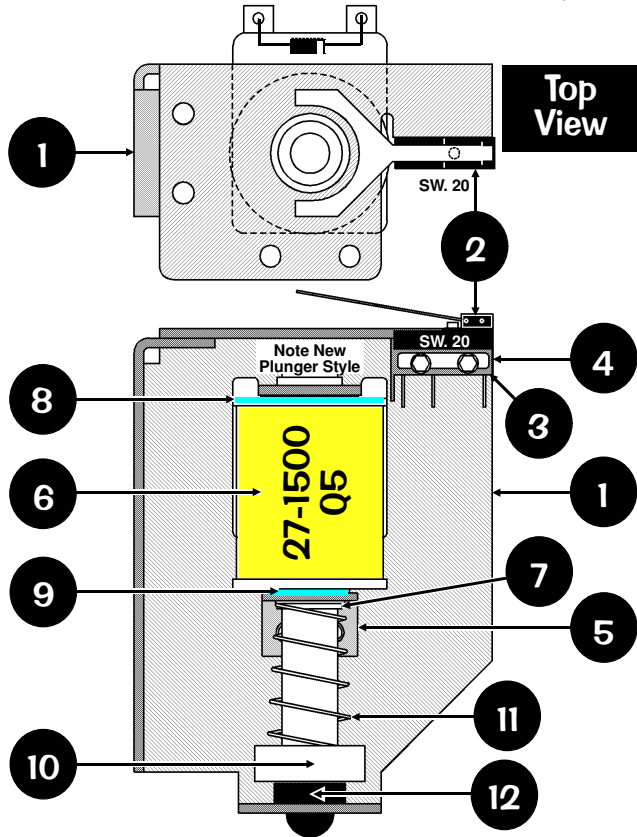

Nº	INDIVIDUAL PART NAME	QTY.	SPI PART Nº
1	VUK Coil Mounting Bracket (Right Style)	1	535-8296-01
Item 1 is secured under the playfield by: #8 X 1/2" HWH AB (Zinc) (Qty. 3) (234-5101-00)			
2	Micro Sw. (Heavy Duty "Y" Flat Actuator)	1	180-5116-01
Switch has a Diode (1N4004) (112-5003-00) on a Terminal Strip below the Playfield.			
3	Switch Lug Insulator (Fiche Paper)	1	545-5759-00
4	Switch Body Protect Plate	1	535-6539-00
Items 2-4 are secured by: #2-56 X 1/2" HWH MS (Serr) Zc TF 3/16" (Qty. 2) (237-5937-02)			
5	Coil Retaining Bracket	1	535-5203-03
Item 5 is secured by: #8-32 X 1/4" PPH MS (Sems) Zinc (Qty. 2) (232-5300-00)			
6	Coil, 27-1500	1	090-5004-00T
Coil has a Diode (1N4004) (112-5003-00) positioned @ top (above lugs next to windings).			
7	Coil Sleeve (Short) (Formost #10-7077)	1	545-5076-01
8	Coil Lug Insulator (Fiche Paper)	1	545-5431-00
9	Spring Washer, 17/32" ID X 3/4" X 1"	1	269-5002-00
10	Plunger Assembly	1	515-5000-02
11	Compression (Relay) Spring	1	266-5020-00
12	Rubber Bumper (Grommet)	1	545-5105-00

Ordering Note: If 500-6659-00 is unavailable, order the individual part(s) actually required. **This assembly is identical** to 500-6290-01, or 500-6290-11, except for **items 6 & 10** (replace with above referenced part numbers for the different Coil & Plunger). If replacing the entire assembly, do not forget to reattach the Wood VUK Spacer (525-5548-00); see Section 4, Chapter 1, **Playfield - General Parts & Switches (Below)**, Page 64 for location.

Take Note:

DOTS: The Switch Diode, 1N4001, is not located on either VUK Assembly (nor included); it's located on a Terminal Strip under the playfield near this assembly. See Section 5, Chapter 2, **Playfield Terminal Strips.**, Page 105, for more details.

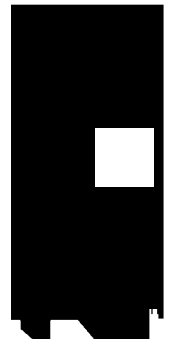

VUK (Vertical Up-Kicker, Right Style) Assembly, 500-6660-00 (Items 1-12)

Launches ball up onto the Upper Mini-Playfield after entry from either Left Plastic Ramps.

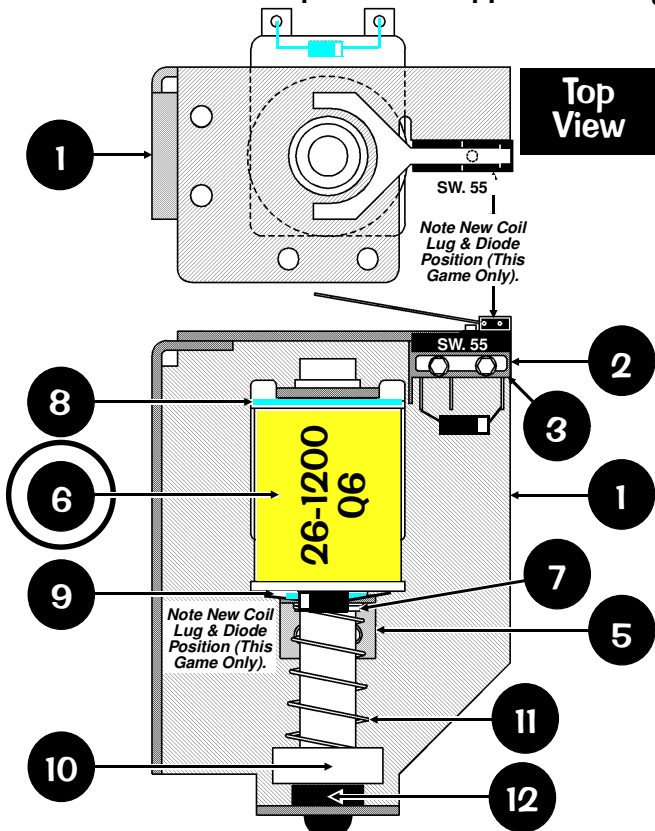

Nº	INDIVIDUAL PART NAME	QTY.	SPI PART Nº
1	VUK Coil Mounting Bracket (Right Style)	1	535-8296-01
Item 1 is secured under the playfield by: #8 X 1/2" HWH AB (Zinc) (Qty. 3) (234-5101-00)			
2	Micro Sw. (Heavy Duty "Y" Flat Actuator)	1	180-5116-01
Switch has a Diode (1N4004) (112-5003-00). Can be replaced with (1N4001) (112-5001-00).			
3	Switch Lug Insulator (Fiche Paper)	1	545-5759-00
4	Switch Body Protect Plate	1	535-6539-00
Items 2-4 are secured by: #2-56 X 1/2" HWH MS (Serr) Zc TF 3/16" (Qty. 2) (237-5937-02)			
5	Coil Retaining Bracket	1	535-5203-03
Item 5 is secured by: #8-32 X 1/4" PPH MS (Sems) Zinc (Qty. 2) (232-5300-00)			
6	Coil, 26-1200 (Note Lug Position)	1	090-5044-00B
Coil has a Diode (1N4004) (112-5003-00) positioned @ bottom (below lugs).			
7	Coil Sleeve (Short) (Formost #10-7077)	1	545-5076-01
8	Coil Lug Insulator (Fiche Paper)	1	545-5431-00
9	Spring Washer, 17/32" ID X 3/4" X 1"	1	269-5002-00
10	Plunger Assembly	1	515-5941-01
11	Compression (Relay) Spring	1	266-5020-00
12	Rubber Bumper (Grommet)	1	545-5105-00

Ordering Note: If 500-6660-00 is unavailable, order the individual part(s) actually required. **This assembly is identical** to 500-6290-01, except for the Coil Lug & Diode Position of **Item 6** (replace Coil with the same orientation as shown in drawing).

Sec. 4: Drawings ...

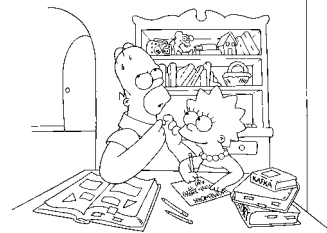
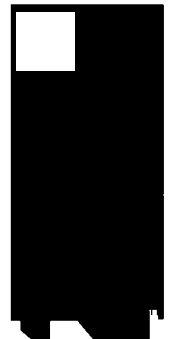

3-Bank Drop Target Assembly, 500-6577-33 (Items 1-19)

Different Views, Target Height Adjustment & Drop Target Removal Procedures on the next page.

Nº	INDIVIDUAL PART NAME	QTY.	SPI PART Nº	Nº	INDIVIDUAL PART NAME	QTY.	SPI PART Nº
1	Bracket, Main Housing	1	535-9126-03	12	Bracket, Target Lift (3-Bank D/T)	1	535-9128-03
Item 1 is secured below the P/F by: #8 X 1/2" HWH AB (Zinc) (Qty. 6) (234-5101-00)							
2	Back Plate (3-Bank Drop Target)	1	535-9127-03	13	Plunger (Drive Coil)	1	530-5410-00
Item 13 is secured to Item 12 by: #10-32 X 3/8" PPH (Sems) (Qty. 1) (232-5401-00)							
3	Bracket, Target Retainer (3-Bank D/T)	1	535-9129-03	To order Items 12-13 assembled with securing hardware, use SPI Nº: 515-7246-00 .			
4	Bracket, Target Back Stop	1	535-9131-03	14	Compression (Return) Spring	1	266-5020-00
5	Bracket, Coil Housing	1	535-7707-00	15	Drop Target White (Rollover)	3	545-5533-01
6	Bracket Cap, Coil Housing	1	515-6533-00	Note: For associated Decals (-11, -12 & -13), see Main Playfield & Mini-Playfield - ... & Decals, Page 67 . Decals not available individually, ordering of Decal Kit is required.			
7	Coil, 26-1200	1	090-5044-00B	16	Spring, Target Reset	3	265-5003-00
Coil has a Diode (1N4004) (112-5003-00) positioned @ bottom (below lugs).							
8	Coil Sleeve	1	545-5709-00	17	Bracket, Trip Coil Mounting	3	535-9130-00
9	Spring Washer (17/32" ID X 3/4" X 1")	1	269-5002-00	18	Coil, 32-1250 (Mini-Bobin) Assembly	3	515-6916-01
To order Items 5-9 assembled with securing hardware, use SPI Nº: 515-6535-03 .							
10	Bracket, Switch (Universal X-Bank D/T)	3	535-7710-00	For Individual Items use : Diode, 1N4004 (112-5003-00), Actuator Flap Plate (535-8597-00) and Retainer Clip (530-5550-00).			
11	Switch (Drop Target)	3	180-5158-00	Item 19 is secured to Item 17 by: #8-32 Nylon Stop Nut (Qty. 1/per) (240-5102-00)			
Each Switch has a Diode (1N4004) (112-5003-00) on a Terminal Strip below the Playfield.							
Item 11 is secured to Item 10 by: #4-40 X 5/8" HWH TF (Qty. 2) (237-5945-00)							
12	Bracket, Target Lift (3-Bank D/T)	1	535-9128-03	19	Height Adj. Screw (#8-32 X 3/4" HWH)	2	237-6010-00
Items 3, 4, 5, 6, 10 & 17 are secured by: #8-32 X 3/8" HWH Swg. (Qty. 2) (237-5975-00)							
Ordering Note: If 500-6577-XX is unavailable, order the individual part(s) actually required.							

Take Note:

DOTS: The Switch Diodes, 1N4001, are not located on this assembly (nor included); they're located on a Terminal Strip under the playfield near this assembly. See Section 5, Chapter 2, **Playfield Terminal Strips...**, Page 105, for more details.

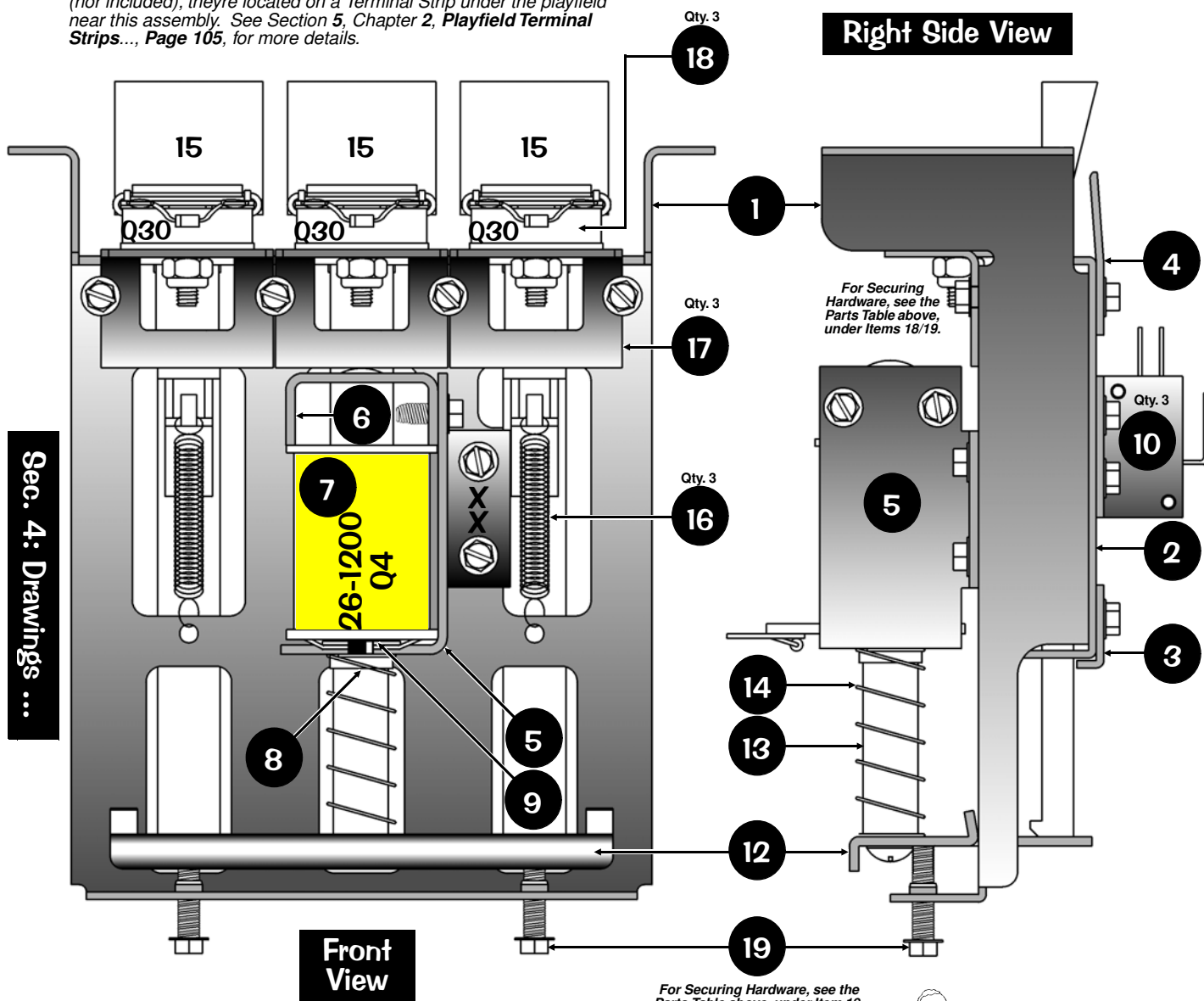

3-Bank Drop Target Assembly, 500-6577-33 (Items 1-19) Continued

Different Views & Parts Table on the previous page.

Target Height Adjustment Procedure:

With the Drop Targets (Rollover) (Item 15) in the **DOWN POSITION**, adjust the height of the Target so the top is *just slightly* over 1/2" above the feet of the Main Housing Bracket (Item 1) as shown below (see **Ref. A**). **Keep in Mind:** This adjustment procedure should have the **TOP SIDE** of the Drop Targets "flush to slightly above" the *playfield surface* after reinstalling the assembly to the underside of the Playfield (see **Ref. A** below). This will ensure a **BALL TRAP** is *not created* where the ball can rest in the target hole above the playfield.

Step 1. Using a 1/4" Nut Driver, loosen or tighten (*turn in or out*) the Height Adjustment Screws (Item 19) through the Target Lift Bracket (Item 12) to raise or lower the Drop Targets to reach desired height as stated above (*using 1/4 turns between each screw to keep Targets even*). **Step 2.** Apply **Blue** Loc-Tite.

Drop Target Removal Procedure:

Although it is possible to remove the Drop Targets with the Assembly secured to the playfield, it would be easier to remove the assembly. The #8-32 X 3/8" Screws to be removed are marked by an "X" in the **Front** and **Back Views**. **Step 1.** Remove the Target Retainer Bracket (Item 3, see **Back View** below). **Step 2.** Turn assembly around and remove the Target Reset Spring (Item 16) with pointed-nose pliers. **Note:** If replacing the middle Target, it may be necessary to remove the Coil Housing Bracket (Item 5) to access the Spring. **Step 3.** Replace Target & Decal (see note in Parts Table under Item 15, previous page) and reassemble. **Step 4.** Recheck the Target Height Adjustment and adjust as necessary per above procedure.

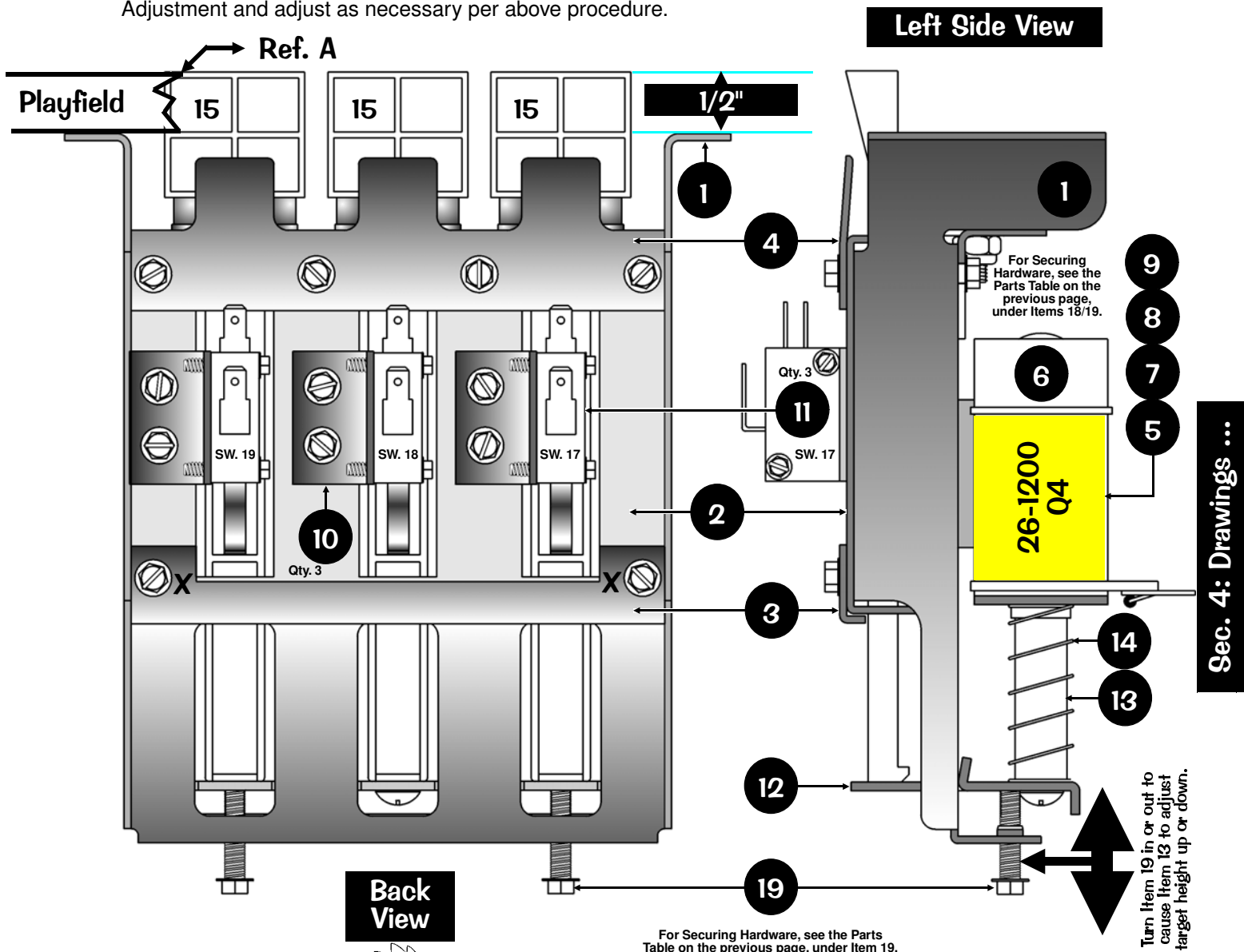

Bart & Skateboard on Rail Individual Parts Only (Items 1-14)

Nº	INDIVIDUAL PART NAME	QTY.	SPI PART Nº	Nº	INDIVIDUAL PART NAME	QTY.	SPI PART Nº
1	Bart & Skateboard (Modified)	1	880-5058-03	8	1 X 15/16" X 3/8" Plastic Spacer Gray	1	254-5000-15
Item 1 is secured at the rear with Items 2 & 6 by: #6 X 1-3/4" PPH (Zinc) (Qty. 1) (232-5009-00) and #6 Riveting Lock Washer (Qty. 1) (246-5000-00) <i>between Post and skateboard</i> . Item 1 is secured at the front with Item 7 by: #6-32 X 3-1/2" PPH MS (Zinc) (Qty. 1) (237-5517-02), #6 Riveting Lock Washer (Qty. 1) (246-5000-00) and #6-32 Nylon Stop Nut (Qty. 1) (240-5005-00)				9	#6 Washer	1	242-5001-00
2	Mounting Plate	1	535-9191-00	10	5/8" X 1/4" Hex Spacer #6-32 Tap	1	254-5008-02
3	Mounting Frame	1	535-9192-00	11	Fender Washer .187" I.D. X .875" O.D. X .048" Zc.	1	254-5059-00
Item 3 is secured above the Playfield at the Front by: #6-32 Nylon Stop Nut (Qty. 2) (240-5005-00) onto Post Hex Base #6-32 Top/#10-32 Bot (Qty. 2) (530-5332-03). Item 3 is secured <u>below</u> the Playfield at the Front by: #10-32 Nylon Stop Nut (Qty. 2) (240-5203-00)				12	Switch Base Plate (Black)	1	535-9195-00
Item 3 is secured above the Playfield at the Rear by: See Items 8-11, next column.				13	Switch Mounting Bracket	2	535-9194-00
4	Buttonhead Rivet (Nylon) .125"ø	2	545-6062-00	14	Micro Switch (Flat Actuator)	2	180-5190-48
5	Pinball (Captive Ball)	1	260-5000-00	Switch has a Diode (1N4004) (112-5003-00). Can be replaced with (1N4001) (112-5001-00). Item 14 (Qty. 1) is secured to Item 12 with Item 13 by: #6-32 X 5/8" HWH Slotted (Zinc) (Qty. 2) (237-5976-04) and Item 14 (Qty. 1) is secured below the playfield with Item 13 by: #6-32 X 3/4" Fin Shank Screw (thru top of playfield) (Qty. 2) (237-5921-02) and #6-32 Nylon Stop Nut (Qty. 1/per) (240-5005-00)			
6	9/16" X 5/16" X 1/8" O.D. Plastic Spacer Gray	1	254-5034-00				
7	2-7/16" X 5/16" X 1/8" O.D. Plastic Spacer Gray	1	254-5035-00				

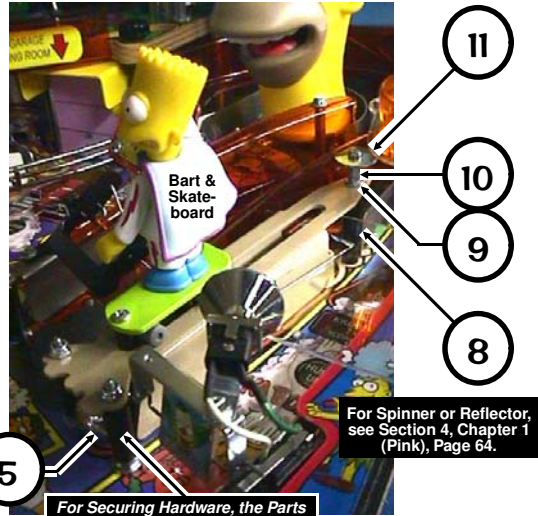
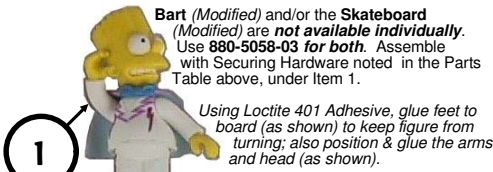

REAR

FRONT

FRONT

REAR

REAR

REAR

FRONT

Sec. 4: Drawings ...

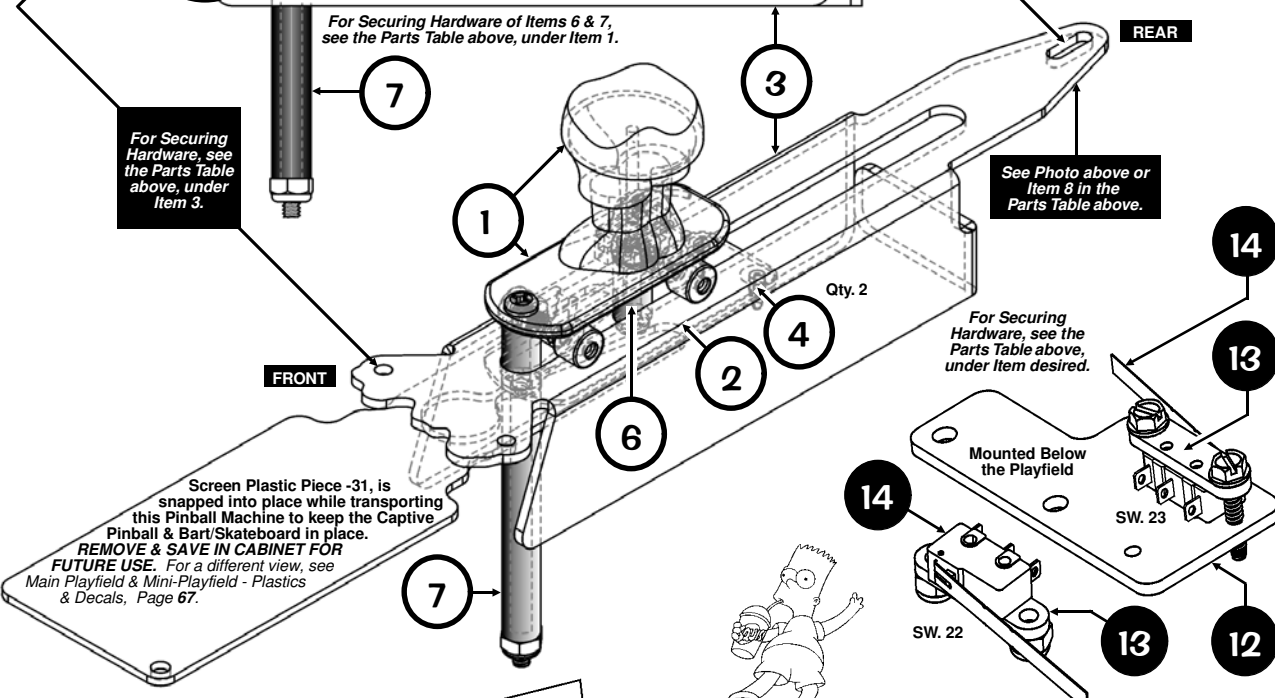

Screen Plastic Piece -31, is snapped into place while transporting this Pinball Machine to keep the Captive Pinball & Bart/Skateboard in place. REMOVE & SAVE IN CABINET FOR FUTURE USE. For a different view, see Main Playfield & Mini-Playfield - Plastics & Decals, Page 67.



Main Playfield - Left & Right Plastic Ramps Individual Parts Only (Items 1-10)

Nº	INDIVIDUAL PART NAME	QTY.	SPI PART Nº	Nº	INDIVIDUAL PART NAME	QTY.	SPI PART Nº
1	Left Plastic Ramp <i>with Ramp Flap only</i>	1	515-7270-00	10	Kit: Plastics (Screened & Clear)	1	803-5000-77
<i>For Individual Items use :</i> Plastic Ramp (Left, No Parts) (545-6046-00), Ramp Flap (535-9096-00), Rivet, 1/8" X 3/16" Lg. (Qty. 2) (249-5001-00) and #6 Lock Washer (Qty. 2) (246-5000-00).				<i>Note: For associated Plastics (-06 -07, -23 & -31), see Main Playfield & Mini-Playfield - Plastics (Screened & Clear) & Decals, Page 67. Plastics are not available individually, ordering of Plastic Kit is required. Plastics shown in the position used, so Securing Hardware can be determined.</i>			
2	Comic Book Guy (Modified)	1	880-5060-01				
3	Right Plastic Ramp <i>with Ramp Flap only</i>	1	515-7272-00				
<i>For Individual Items use :</i> Plastic Ramp (Right, No Parts) (545-6044-00), Ramp Flap (535-9094-00), Rivet, 1/8" X 3/16" Lg. (Qty. 2) (249-5001-00) and #6 Lock Washer (Qty. 2) (246-5000-00).							
4	Roll-Under Gate & Switch Assembly	3	515-7206-00				
<i>For Individual Items use :</i> Roll-Under Switch Mounting Bracket (Black) (535-9041-00), Wire Gate (535-9043-48), Micro Switch (Short Flat Actuator) (180-5190-28), Switch Diode (1N4004) (112-5003-00), Switch Body Protect Plate (535-6539-00) and #2-56 X 1/2" HWH Sr (Qty. 2) (237-5937-02)							
5	Ramp Protector, Ball Guide (<i>Rt. Ramp</i>)	1	535-9216-00				
6	Mini-Mars Lite Cover (<i>Snap-In</i>) Red	1	550-5030-02				
7	Mini-Mars Lite Cover (<i>Snap-In</i>) Amber	1	550-5030-03				
8	#906 Wedge Base Bulb (Clear)	2	165-5004-00				
9	IDC Snap-Pn Socket <i>No Diode</i>	2	077-5216-01				

For Securing Hardware of Items 1-5 & 10 (Reference Only), see A-R below.

Securing Hardware A-R

- A 3" X 1/4" Hex Spacer #6-32 Tap, 234-5008-14
- B 1" X 3/8" Plastic Spacer Gray, 254-5000-04 and #8-32 X 1-1/2" HWH MS (Serr) Zinc, 237-5946-00
- C #8-32 Nylon Stop Nut, 240-5102-00
- D #8-32 X 1/2" HWH Swage (Ser) Zinc, 237-5975-01
- E #6 X 1/2" PTH A (Zinc), 237-5809-00
- F 1-1/16" 1-Groove Plastic Post (Clear) 550-5059-01 and #6 X 1-1/2" PPH Zinc, 232-5007-00
- G 2" X 1/4" Hex Spacer #6-32 Tap, 234-5008-07
- H Ramp Mounting Bracket, 515-6508-00 and #6 X 1/2" PTH AB (Qty. 2/per), 237-5809-00
- I 1/2" X 3/8" Plastic Spacer Gray, 254-5000-01 and #6 X 7/8" PRH AB Zinc, 237-5003-00
- J 2-3/4" X 1/4" Hex Spacer #6-32 Tap, 234-5008-15
- K #8-32 X 1/2" PPH MS (Zinc), 237-5602-00
- L #4 X 5/8" PFH (Black), 237-5833-00 (1 on each side of the Ramp Flap)
- M #6-32 Nylon Stop Nut, 240-5005-00 and #6 Washer, 242-5001-00 on a Post Hex Base #6-32 Top/#8-32 Bot, 530-5332-03 (#8-32 Nylon Stop Nut, 240-5102-00, below the playfield)
- N 2-5/8" X 1/4" Hex Spacer #6-32 Tap, 234-5008-08
- O 1-3/8" X 1/4" Hex Spacer #6-32 Tap, 234-5008-33
- P 1/4" X 3/8" Plastic Spacer Gray, 254-5000-02, #8-32 X 5/8" HWH MS (Serr) Zinc TF, 237-5951-00 and #8-32 Nylon Stop Nut, 240-5102-00
- Q #8 X 1" HWH AB, 234-5105-00
- R 1-1/4" X 1/4" Hex Spacer #6-32 Tap, 234-5008-11

Hex Spacers A, G, J, N, O & R used to support Plastic Ramps, require:
#6-32 X 3/8" PPH MS (Sems) Zinc, 232-5201-00 and #6 Washer, 242-5001-00
Hex Spacers secured directly on the Playfield are secured onto a: #6-32 X 3/4" Fin Shank Screw, 237-5921-02

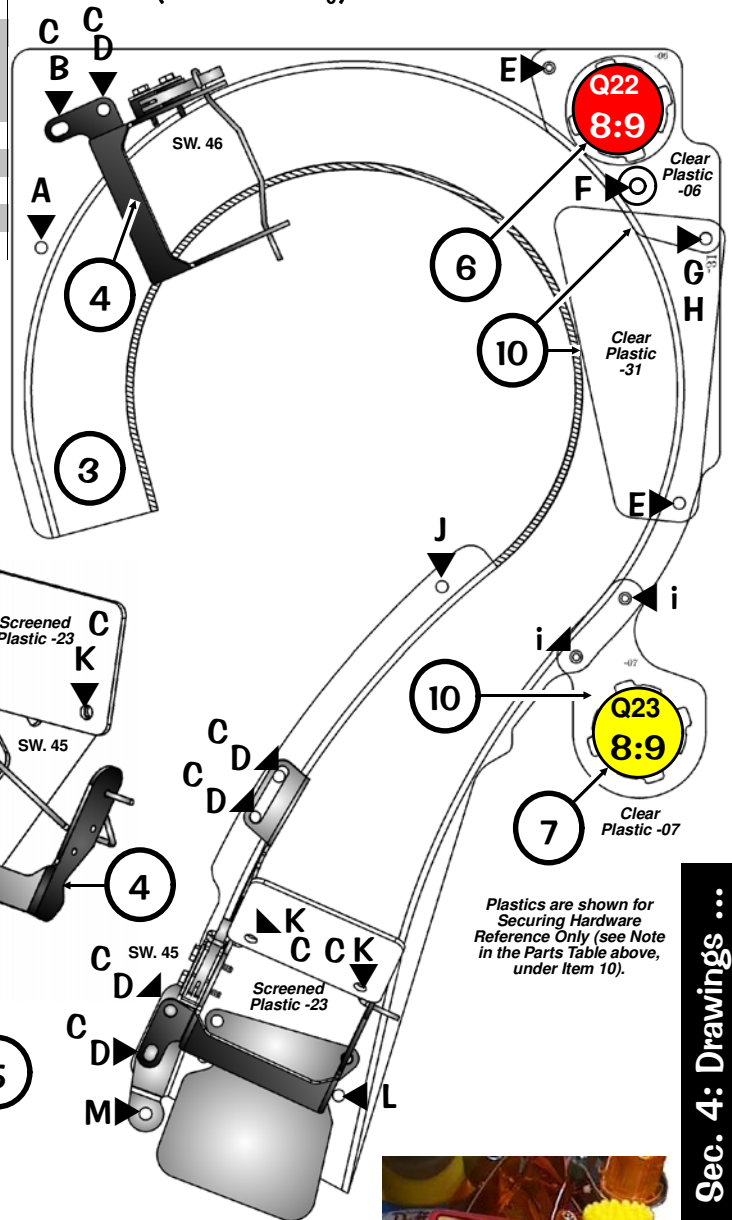

Plastics are shown for Securing Hardware Reference Only (see Note in the Parts Table above, under item 10).



Sec. 4: Drawings ...



Main Playfield & Mini-Playfield - Ramps Overview

Securing Hardware C, L, N, S-W

- C** #8-32 Nylon Stop Nut, 240-5102-00
- L** #4 X 5/8" PFH (Black), 237-5833-00 (1 on each side of the Ramp Flap)
- N** 2-5/8" X 1/4" Hex Spacer #6-32 Tap, 234-5008-08
- S** 5/8" X 1/4" Hex Spacer #6-32 Tap, 234-5008-02
- T** 1/2" X 1/4" Hex Spacer #6-32 Tap, 234-5008-03
- U** 1-3/4" X 1/4" Hex Spacer #6-32 Tap, 234-5008-10
- V** 2-1/4" X 1/4" Hex Spacer #6-32 Tap, 234-5008-18
- W** 1" X 1/4" Hex Spacer #6-32 Tap, 234-5008-06

Hex Spacers N also required 1 of each:

- #6-32 X 3/8" PPH MS (Sems) Zc., 232-5201-00 & #6 Washer, 242-5001-00

Hex Spacers S-W also required 1 of each:

- #6-32 X 3/8" PPH MS (Sems) Zc., 232-5201-00 & #8 Washer, 242-5015-00, (2/per on top/bottom of wire)



Sec. 4: Drawings ...





30° Eject Assembly, 500-6661-00 (Items 1-8)

When energized, opens the Garage Door (entrance to the 2nd Level Mini-Playfield)

Nº	INDIVIDUAL PART NAME	QTY.	SPI PART Nº
1	Mounting Bracket 30° Bend (Frame)	1	535-8932-00
Item 1 is secured below the playfield by: #8 X 1/2" HWH AB (Zinc) (Qty. 2) (234-5101-00)			
2	Coil Retaining Bracket	1	535-5203-03
Item 2 is secured to Item 1 by: #8-32 X 1/4" PPH MS (Sems) (Qty. 2) (232-5300-00)			
3	Coil, 26-1200	1	090-5044-00T
Coil has a Diode (1N4004) (112-5003-00) positioned @ top (above lugs next to windings).			
4	Coil Sleeve (Short) (Formost #10-7077)	1	545-5076-01
5	Spring Washer (17/32" ID X 3/4" X 1")	0	Not Required
6	Long Plunger Assembly	1	515-7223-00
7	Compression (Return) Spring	0	Not Required
8	Rubber Bumper (Grommet)	1	545-5105-00

Ordering Note: If 500-6661-00 is unavailable, order the individual part(s) actually required. This assembly is identical to 500-6511-01, except for Items 3 & 7 (replace with above referenced part number for the different Plunger; the Compression Spring is Not Required).

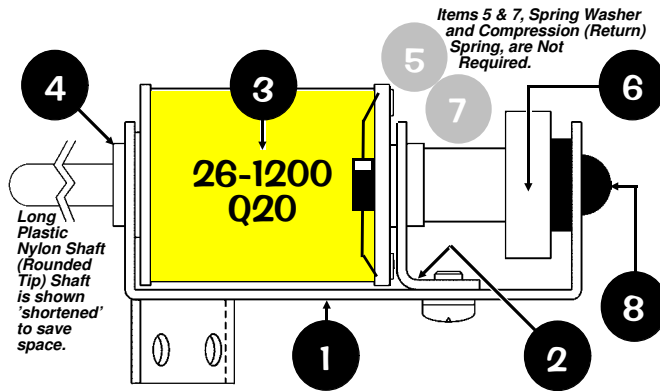
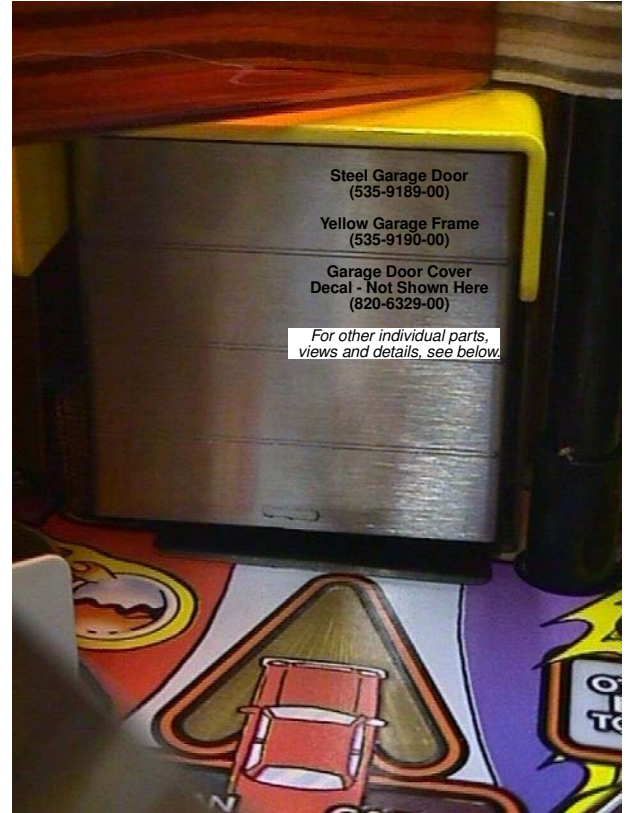

2ND LEVEL MINI-PLAYFIELD (BELOW)

Garage Door Individual Parts Only (Items 1-7)

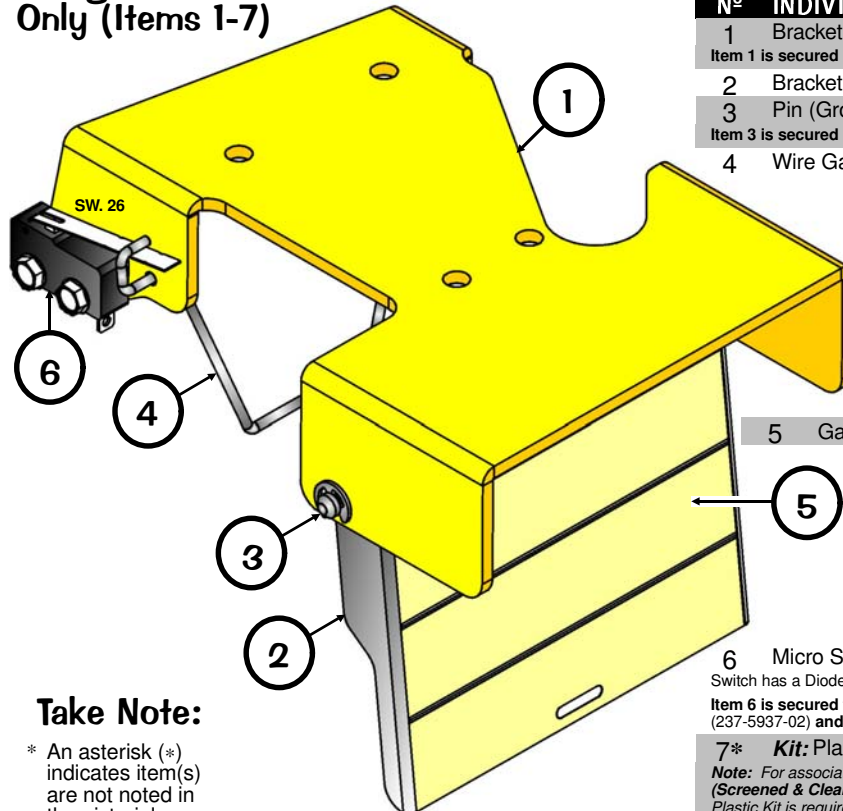

Nº	INDIVIDUAL PART NAME	QTY.	SPI PART Nº
1	Bracket, Garage Frame (Yellow)	1	535-9190-00
Item 1 is secured by: #8 X 1/2" HWH AB (Zinc) (Qty. 6) (234-5101-00)			
2	Bracket, Garage Door	1	535-9189-00
3	Pin (Grooved), Door Hinge (Mount)	1	530-5630-00
Item 3 is secured by: Retaining Ring (E-Ring) 5/32" ø (Qty. 2) (270-5021-15)			
4	Wire Gate	1	535-9043-56

5	Garage Door Cover Decal	1	820-6329-00
---	-------------------------	---	-------------

Take Note:

* An asterisk (*) indicates item(s) are not noted in the pictorials.

6	Micro Switch (Short Flat Actuator)	1	180-5190-28
Switch has a Diode (1N4004) (112-5003-00). Can be replaced with (1N4001) (112-5001-00).			

Item 6 is secured to Item 1 by: #2-56 X 1/2" HWH (Sr) Uns #4HD TR3 BO (Qty. 2) (237-5937-02) and #2-56 Nylon Stop Nut (Qty. 2) (240-5321-00)

7*	Kit: Plastics (Screened & Clear)	1	803-5000-77
----	----------------------------------	---	-------------

Note: For associated Plastics (-29), see Main Playfield & Mini-Playfield - Plastics (Screened & Clear) & Decals, Page 67. Plastics are not available individually, ordering of Plastic Kit is required. Clear Plastic -29 is not shown in this pictorial (positioned at the rear 2 holes). It is secured by the same hardware (Qty. 2) as noted under Item 1 above.



2ND LEVEL MINI-PLAYFIELD (BELOW)

General Individual Parts Below Only (1 & A-D)

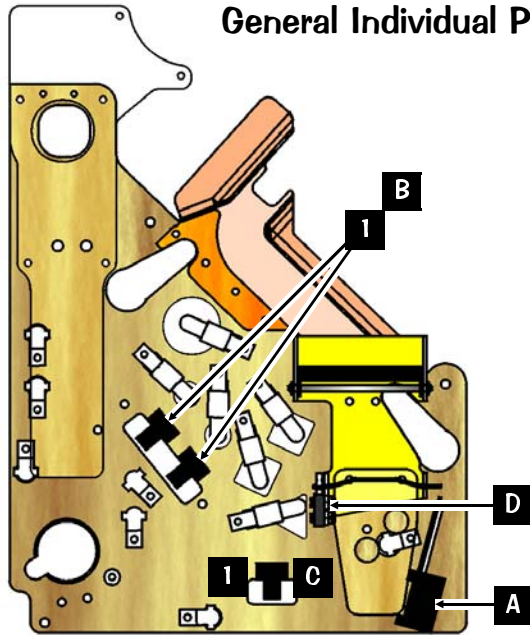

N°	BELOW MINI-P/F PART NAME	QTY.	SPI PART N°
Brackets for Mounting			
1	Switch Back Plate (Stand-Up Target)	3	535-6452-00
	Target (Stand-Up) Bracket	3	535-6896-00
Item 1 requires: Foam Pad (Qty. 1/per) (626-5029-00) on Target Bracket.			
Switches			
A	Micro Sw. Roll-Over Right Brkt. Assy.	1	500-6227-02
Item A is secured by: #6 X 1/2" HWH AB (Zinc) (Qty. 2/per) (234-5001-02)			
B	Switch & Target Assy. 1" Round (Grn.)	2	515-5966-04
C	Switch & Target Assy. 1" Round (Red)	1	515-5966-02
Items B-C are secured by: #6 X 1/2" HWH AB Zinc (Qty. 2/per) (234-5001-02)			
D	Micro Switch	1	180-5190-28

For Plastic Pieces or Decals:
See Main Playfield & Mini-Playfield - ..., Page 67 (The Pink Pages).

For Metal Posts (Screws), Hex Spacers and Posts & Spacers:
See Main Playfield & Mini-Playfield - ..., Pages 69-71 (The Pink Pages).

For Small Bayonet Type Bulbs & Sockets and Wedge Base Bulbs & Sockets:
See Main Playfield & Mini-Playfield - ..., Pages 72 & 74 (The Pink Pages).

For complete Switch Target Assemblies:
See Appendix I at the end of this manual.

2ND LEVEL MINI-PLAYFIELD (ABOVE)

General Individual Parts Above Only (1-13 & A-C)

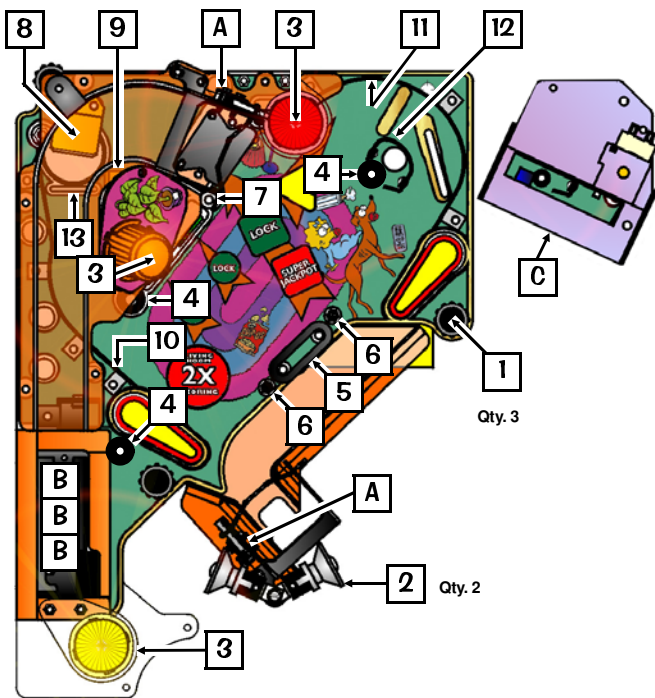

N°	ABOVE MINI-P/F PART NAME	QTY.	SPI PART N°
PF			
	Mini-P/F Screened w/ Inserts & <u>NO</u> Parts	1	830-5177-01
	Mini-P/F Complete w/ Inserts & <u>ALL</u> Parts	1	505-6004-77-77B
General Items			
1	Thumb Screw (Black Knob)	3	355-5050-00
Item 1 secures down the 2nd Level Mini-Playfield onto #10-32 X 3-1/2" P/F Post (Black)			
For actual size view of Post, see Main P/F & Mini-P/F - Metal Posts & Nuts, Pink Page 69.			
2	Light Reflector (Silver Color Plastic)	2	545-5409-01
3	Mini-Mars Lite Cover (Snap-In) (see Note)	3	550-5030-XX
Item 3 come in various colors, replace XX with the following 2-Digit Numbers: -02 Red (Qty. 1), -03 Amber (Qty. 1) & -06 Yellow (Qty. 1)			
Rubber Parts			
4	Rubber Ring, Black 3/16" I.D.	3	545-5348-01
5	Rubber Ring, Black 3/4" I.D.	1	545-5348-04
6	Rubber Ring, Black 3/8" O.D.	2	545-5348-19
7	Bumper BLACK (Post Sleeve, Tall)	2	545-5308-00
Bracket with Wire Gate			
8	Snubber Bracket	1	535-8250-04
Brackets for Ball Stops, Traps or Protect			
9	Bracket (identical to Coil Mounting)	1	535-7356-00
Item 9 is secured by: #8 X 1/2" HWH AB (Zinc) (Qty. 2) (234-5101-00)			
Metal Flat Rails, Wire Forms & Ball Guides			
10	Metal Rail (Mini-P/F, Left)	1	535-9087-00
11	Metal Rail (Mini-P/F, Loop)	1	535-9089-00
12	Metal Rail (Mini-P/F, Loop Inside)	1	535-9090-00
Items 10-12 are secured at Tabs by: #8 X 1/2" HWH AB (Z.) (Qty. 1/per tab) (234-5101-00)			
13	Snubber Wire 1"	1	535-5373-00
Switches & Misc. PC Board			
A	Micro Switch (x2 Ramps)	2	180-5190-28
Item A requires a Switch Body Protect Plate (Qty. 1/ea.) (535-6539-00) & is secured by: #2-56 X 1/2" HWH Sr Uns #4HD TR3 Black (Qty. 2) (237-5937-02)			
B	Micro Switch (Roller Actuator, Lite Force)	3	180-5119-02
Item B is secured by: #2-56 X 1/2" HWH (Qty. 2/per) (237-5937-02)			
C	Color Dot Display (5X7) x4 PC Bd.	1	520-5219-00
More information and views in Sec. 5, Chp. 4, on Pages 140-141.			

Sec. 4: Drawings ...

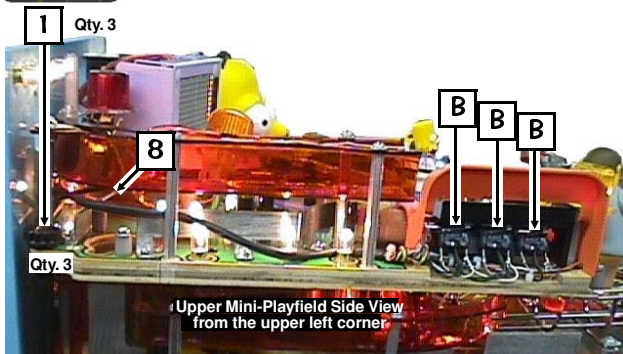

2ND LEVEL MINI-PLAYFIELD (ABOVE) Couch Ball-Lock Individual Parts Only (Items 1-13)

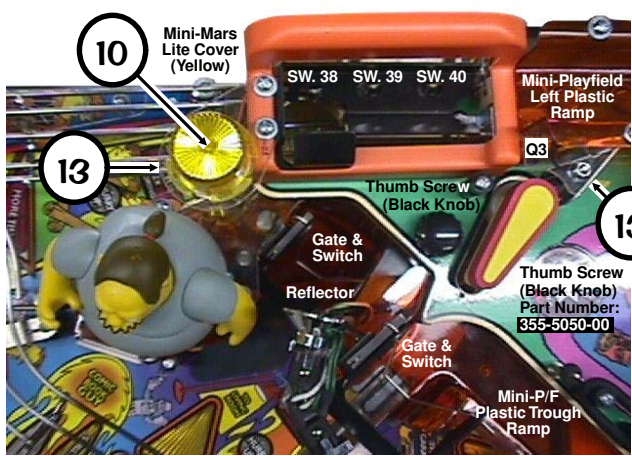
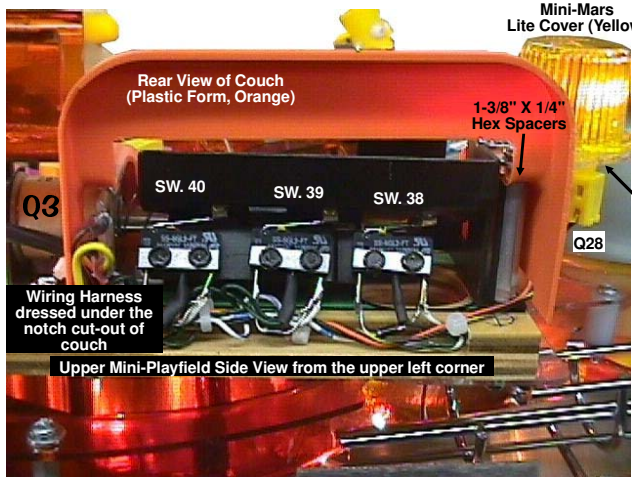

Plastic Ramps on Mini-Playfield: See page after next.

Nº	INDIVIDUAL PART NAME	QTY.	SPI PART Nº
1 ‡	Couch Weldment Frame (Black)	1	535-9193-00
	‡ If Required: Bracket, Reinforcement	1	535-9307-00
Item 1 is secured at the back tab by: #8 X 1/2" HWH AB Zinc (Qty. 1) (234-5101-00)			
Item 1 is secured at the front tab by: #6-32 X 3/4" Fin Shank Screw (Qty. 2) (237-5921-02) and 1-3/8" X 1/4" Hex Spacer #6-32 Tap (Qty. 2) (254-5008-33)			
2	Couch (Plastic Form, Orange)	1	545-6063-00
Item 2 is secured onto the Hex Spacers by: #6-32 X 3/8" PPH MS (Sems) Zinc (Qty. 2) (232-5201-00 and #6 Washer (Qty. 2) (242-5001-00) under Plastic Piece -03*.			
3	Micro Switch (Roller Actuator, Lite-Force)	3	180-5119-02
Item 3 is secured to Item 1 by: #2-56 X 1/2" HWH (Sr) UNS #4HD TR3 BO (Qty. 6) (237-5937-02) Switch has a Diode (1N4004) (112-5003-00). Can be replaced with (1N4001) (112-5001-00).			
4	(Mini) Coil Retainer	1	535-7321-01
Item 4 is secured to Item 1 by: #6-32 X 1/4" HWH Swage (Serr) Zc. (Qty. 2) (237-5976-01)			
5	Coil, 28-1050 (Mini-Bobin)	1	090-5046-00
Coil has a Diode (1N4004) (112-5003-00) positioned @ top (above lugs next to windings).			
6	Coil Sleeve	1	545-5442-00
7	Plunger (Shaft)	1	530-5631-00
Item 7 is secured in Item 4 with: Retaining Ring (E-Ring) 5/16" o (Qty. 1) (270-5003-00)			
8	Nyliner - 5L1-FF Thomson	1	545-5485-00
9	Compression (Return) Spring	1	266-5043-00
10	Mini-Mars Lite Cover (Snap-In) Amber	1	550-5030-03
11	#906 Wedge Base Bulb (Clear)	2	165-5004-00
12	IDC Snap-Pn Socket No Diode	2	077-5216-01
13*	Kit: Plastics (Screened & Clear)	1	803-5000-77

Note: For associated Plastics (-03 & -28), see Main Playfield & Mini-Playfield - Plastics (Screened & Clear) & Decals, Page 67. Plastics are not available individually, ordering of Plastic Kit is required. For position of Clear Plastic -03 & -28 see photo. * Not shown in drawing below for clarity.

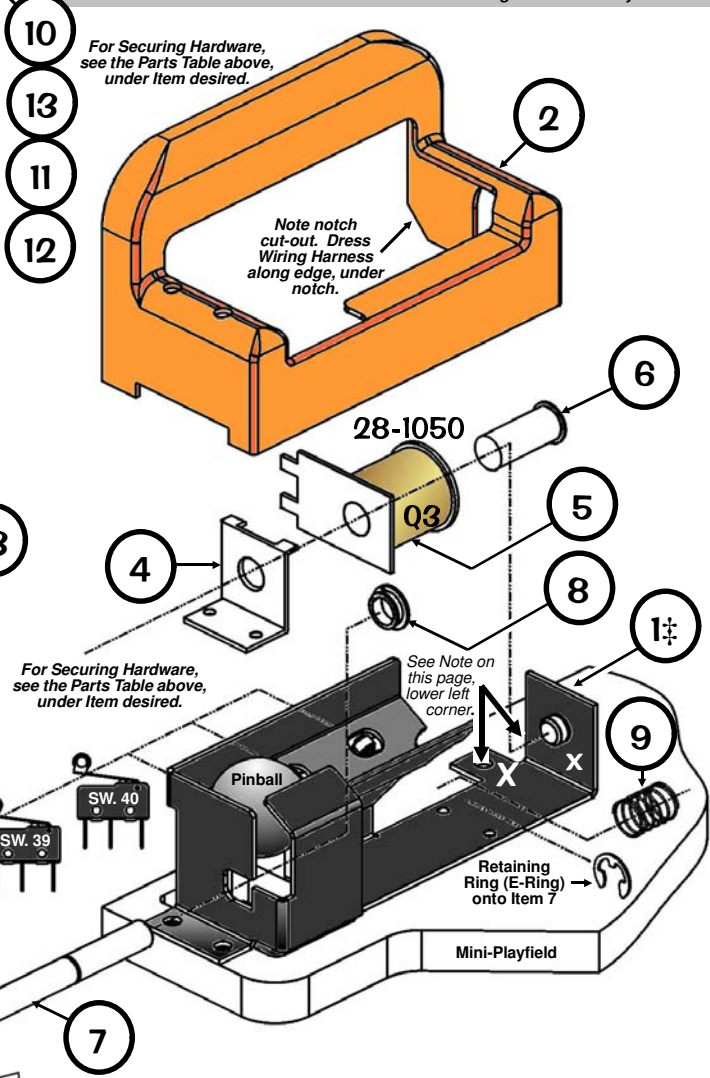

Note: If you find Item 1, Couch Weldment Frame (Black), bending in the rear (marked with an "x"), order the Couch Reinforcement Bracket, 535-9307-00. It slides into place, using the same hardware at the location marked with capital "X".



2ND LEVEL MINI-PLAYFIELD (ABOVE)
TV (Color Dot Display) & LED (Mode Signifier) Individual Parts Only (Items 1-11)

Nº	INDIVIDUAL PART NAME	QTY.	SPI PART Nº	Nº	INDIVIDUAL PART NAME	QTY.	SPI PART Nº
1	TV Weldment Frame (Violet)	1	515-7263-00	7	Compression (Return) Spring	1	266-5043-00
Item 1 is secured by: #6-32 X 3/4" Fin Shank Screw (Qty. 2) (237-5921-02), Washer ("fat") 13/64" I.D. X 5/8" O.D. X .105 (Qty. 2) (242-5039-00), 4" X 1/4" Hex Spacer #6-32 Tap (Qty. 2) (254-5008-21) [Front], 1-1/4" Hex Spacer #6-32 Tap (Qty. 2) (254-5008-11) [Rear], #6-32 X 3/8" PPH MS (Sems) Zinc (Qty. 2) (232-5201-00) and #6 Washer (Qty. 2) (242-5001-00)				8	Color Dot Display (5X7) x4 PCB	1	520-5219-00
				Item 8 is secured to Item 1 by: PCB Fastener (6mm) White Nylon (Qty. 4) (237-5008-00)			
2	(Mini) Coil Retainer	1	535-7321-01	9	Bracket, Mode LED PCB Mount (Blk)	1	535-9232-00
Item 2 is secured to Item 1 by: #6-32 X 1/4" HWH Swage (Serr) Zc. (Qty. 2) (237-5976-01)				Item 9 is secured to the BACKPANEL by: #8-32 X 3/4" HWH Swage (Serr) Zinc (Qty. 3) (237-5975-02)			
3	Coil, 28-1050 (Mini-Bobin)	1	090-5046-00	10	LED PCB (Mode Signifier)	1	520-5225-00
Coil has a Diode (1N4004) (112-5003-00) positioned @ top (above lugs next to windings).				Item 10 is secured to Item 9 by: #6-32 X 5/8" PEM (Self-Clinching) Stud (Zinc) (Qty. 3) (237-6131-10), #6-32 Keps Nut (Qty. 3) (240-5008-00) [between Plastic -24 & PCB] and #6-32 Nylon Stop Nut (Qty. 3) (240-5005-00)			
4	Coil Sleeve	1	545-5442-00	11	Kit: Plastics (Screened & Clear)	1	803-5000-77
5	Plunger (Shaft)	1	530-5629-00	Kit: Game Specific Decals		1	802-5000-77
Item 5 is secured in Item 2 with: Retaining Ring (E-Ring) 5/16" ø (Qty. 1) (270-5003-00)				Note: For associated Plastic (-24) and Decal (-16), see Main Playfield & Mini-Playfield - Plastics (Screened & Clear) & Decals , Page 67. Plastics & Decals are not available individually, ordering of Plastic and/or Decal Kit is required.			
6	Nyliner - 5L1-FF Thomson	1	545-5485-00				

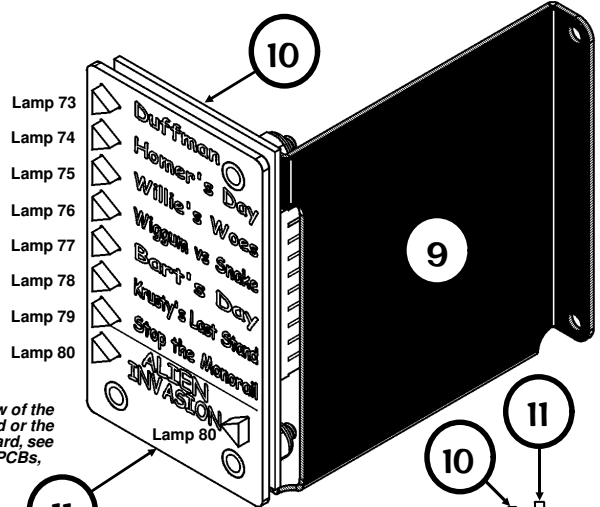
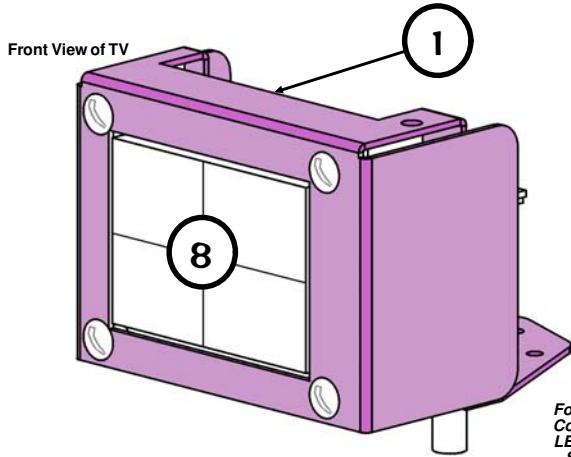

For a photographic view of the Color Dot Display Board or the LED Mode Signifier Board, see Section 5, Chapter 4, PCBs, Pages 140-141.

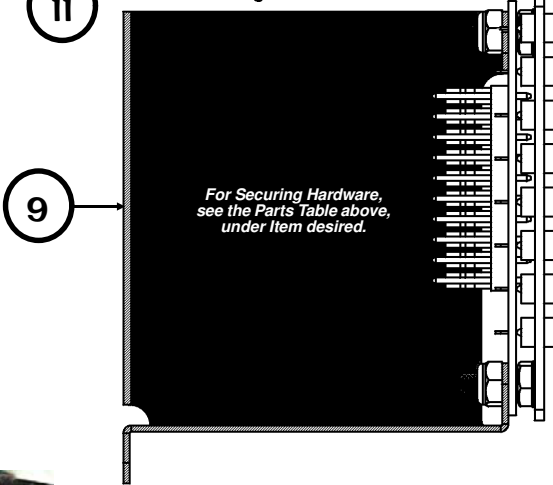
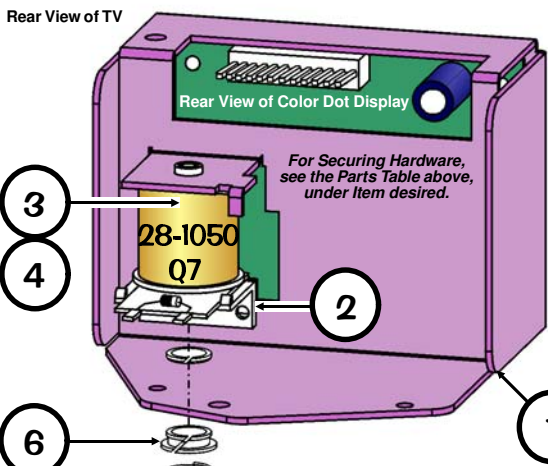

Sec. 4: Drawings ...

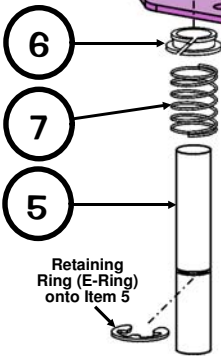

For Securing Hardware, see the Parts Table above, under Item desired.

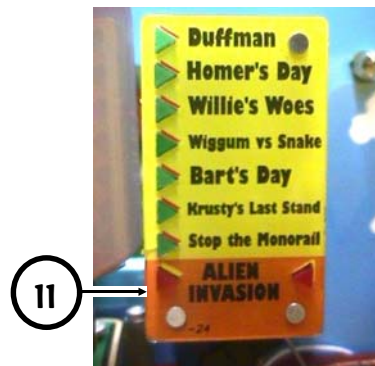
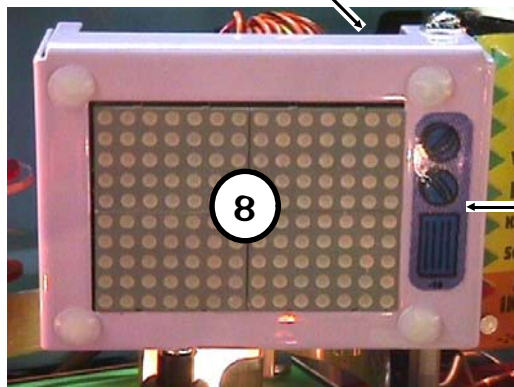

2ND LEVEL MINI-PLAYFIELD (ABOVE)

Left Plastic Ramp & Plastic Trough Ramp Individual Parts Only (Items 1-11)

Nº	INDIVIDUAL PART NAME	QTY.	SPI PART Nº	Nº	INDIVIDUAL PART NAME	QTY.	SPI PART Nº
1	Left Plastic Ramp <i>with Ramp Flap only</i>	1	515-7273-00	5	Mini-Mars Lite Cover (Snap-In) Amber	1	550-5030-03
<i>For Individual Items use :</i> Plastic Ramp (Left, No Parts) (545-6047-00), Ramp Flap (535-9093-00), Rivet, 1/8"o X 3/16" Lg. (Qty. 2) (249-5001-00) and #6 Lock Washer (Qty. 2) (246-5000-00).							
2	Plastic Trough Ramp (<i>Plain, No Parts</i>)	1	545-6048-00	6	#906 Wedge Base Bulb (Clear)	2	165-5004-00
3	Roll-Under Gate & Switch Assembly	2	515-7206-00	7	IDC Snap-Pn Socket No Diode	2	077-5216-01
<i>For Individual Items use :</i> Roll-Under Switch Mounting Bracket (Black) (535-9041-00), Wire Gate (535-9043-48), Micro Switch (Short Flat Actuator) (180-5190-28), Switch Diode (1N4004) (112-5003-00), Switch Body Protect Plate (535-6539-00) and #2-56 X 1/2" HWH Sr (Qty. 2) (237-5937-02)							
4	Ramp Protector, Ball Guide (<i>Left Ramp</i>)	1	535-9217-00	8	Light Reflector (Silver Color Plastic)	2	545-5409-01
				9	#555 Wedge Base Bulb (Clear)	2	165-5002-00
				10	Wedge Base Socket (Laydown)	2	077-5026-01
				11	Kit: Plastics (Screened & Clear) Kit: Game Specific Decals	1	803-5000-77 802-5000-77
<i>Note: For associated Plastic (-04) and Decal (-15), see Main Playfield & Mini-Playfield - Plastics (Screened & Clear) & Decals, Page 67. Plastics & Decals are not available individually, ordering of Plastic and/or Decal Kit is required. Plastics shown in the position used, so Securing Hardware can be determined.</i>							

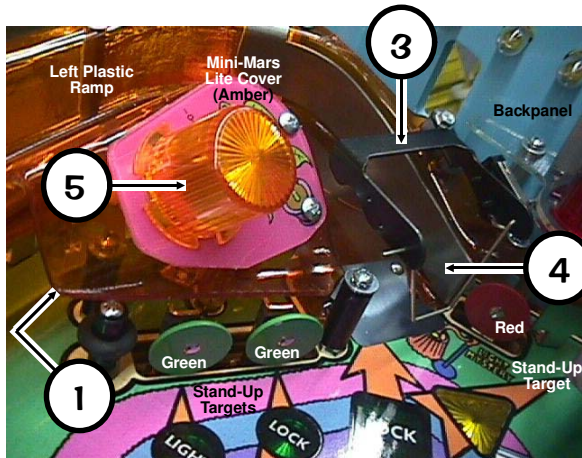

For Securing Hardware of Items 1-4, 10 & 11 (Reference Only), see A-K below.

Securing Hardware A-K

- A 2-3/4" X 1/4" Hex Spacer #6-32 Tap, 234-5008-15
 - B 1-1/8" X 1/4" Hex Spacer #6-32 Tap, 234-5008-17
 - C 1/4" X 3/8" Plastic Spacer Gray, 254-5000-02
 - D #6-32 X 1/2" HWH Swage (Ser) Zinc, 237-5976-03
 - E #6-32 Nylon Stop Nut, 240-5005-00
 - F #8-32 X 1/2" HWH Swage (Ser) Zinc, 237-5975-01
 - G #8-32 Nylon Stop Nut, 240-5102-00
 - H #8-32 X 5/8" HWH MS (Ser) Zinc TF, 237-5951-00
 - I #6 X 1/2" PTH A (Zinc), 237-5809-00
 - J #4 X 5/8" PFH (Black), 237-5833-00 (1 on each side of the Ramp Flap)
 - K #6 X 3/8" HWH AB (Zinc), 234-5000-00
- Hex Spacers **A** and **B** used to support Plastic Ramps, require: #6-32 X 3/8" PPH MS (Sems) Zinc, 232-5201-00 and #6 Washer, 242-5001-00
- Hex Spacers secured directly on the Mini-Playfield are secured onto a: #6-32 X 3/4" Fin Shank Screw, 237-5921-02

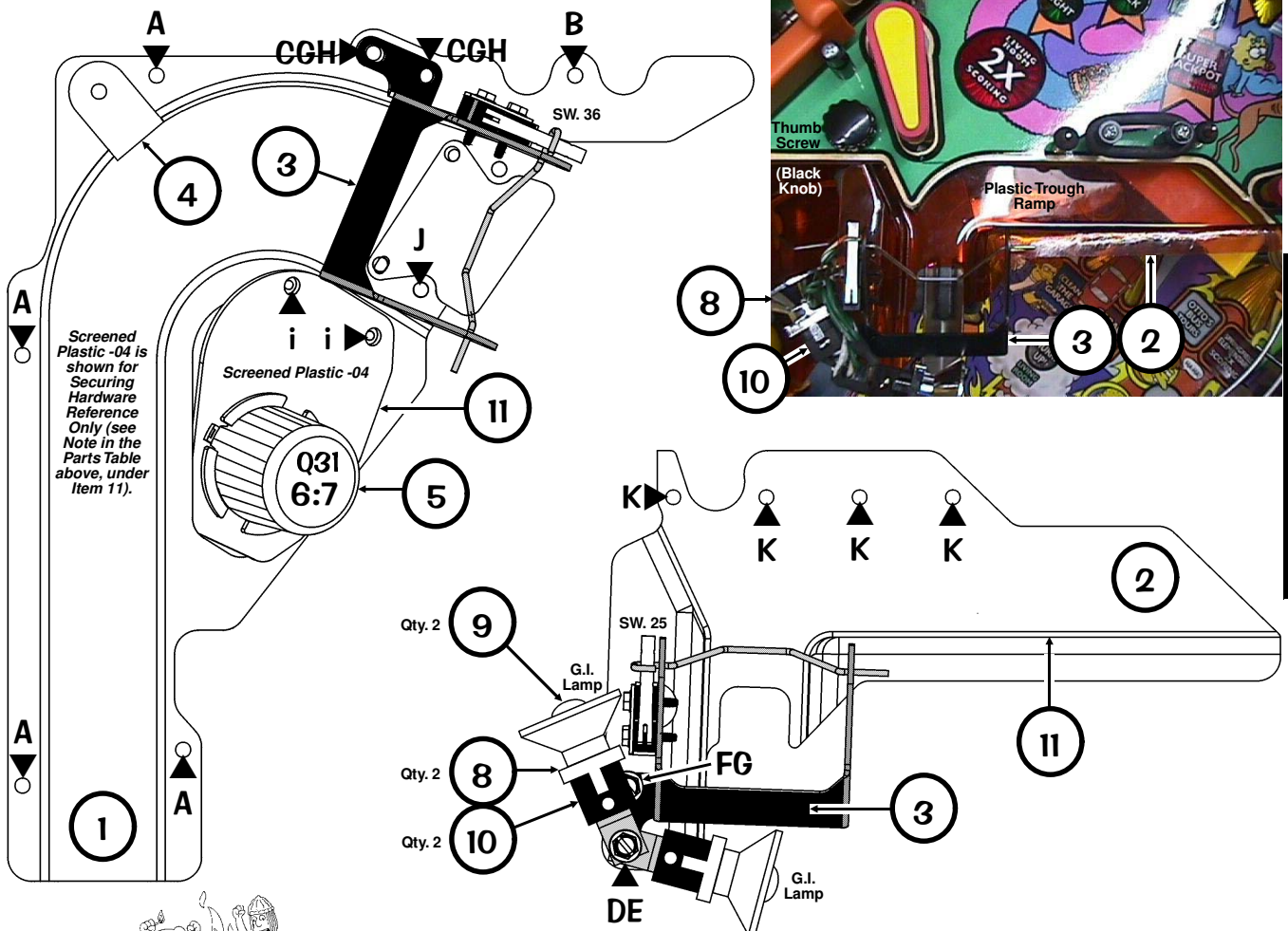

Sec. 4: Drawings ...



UK ONLY OPTIONAL
Ball Deflector Assemblies, 500-5788-02 (Qty. 2) (Items 1-8)

Nº	INDIVIDUAL PART NAME	QTY.	SPI PART Nº
1	Ball Deflector Coil Mounting Bracket	1	535-6857-02
Item 1 is secured below the playfield by: #8 X 1/2" HWH AB (Zinc) (Qty. 4) (234-5101-00)			
2	Coil Retaining Bracket	1	535-5203-03
Item 2 is secured by: #8-32 X 1/4" PPH MS (Sems) Zinc (Qty. 2) (232-5300-00)			
3	Coil, 26-1200	1	090-5044-00T
Coil has a Diode (1N4004) (112-5003-00) positioned @ top (above lugs next to windings).			
4	Coil Sleeve (Short) (Formost #10-7077)	1	545-5076-01
5	Spring Washer (17/32" ID X 3/4" X 1")	1	269-5002-00
6	Solid Plunger Assembly	1	515-6858-00
7	Compression (Relay) Spring	1	266-5022-01
8	#10-32 Adj. Spindle Stop w/Rubber Tip	1	280-5014-00
Item 8 is secured by: #10-32 Keps Nut (Qty. 1) (240-5208-00)			

Ordering Note: If 500-5788-02 is unavailable, order the individual part(s) actually required.

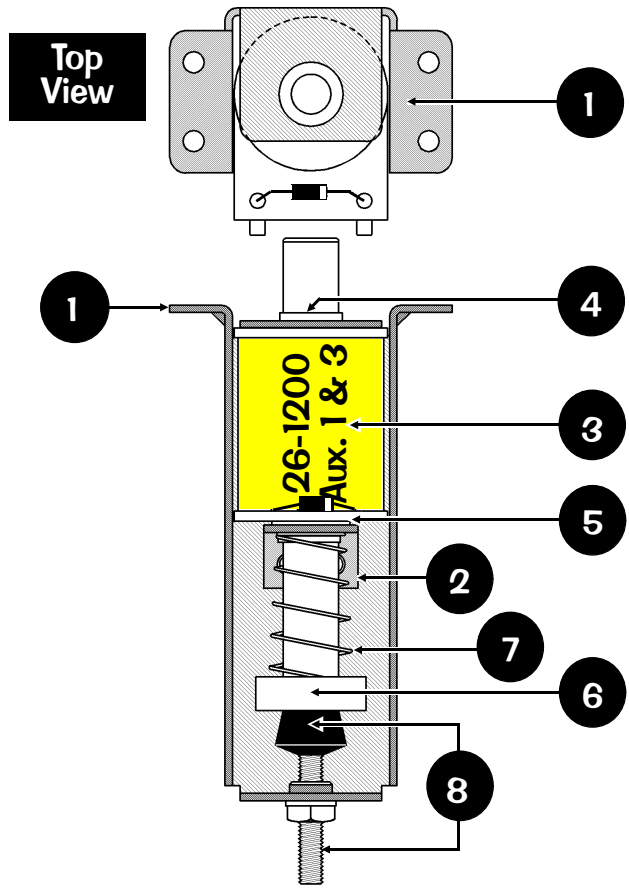

UK ONLY OPTIONAL
Up/Down Post Assembly, 500-6293-00 (Items 1-9)

Nº	INDIVIDUAL PART NAME	QTY.	SPI PART Nº
1	Up/Down Post Coil Mounting Bracket	1	515-6840-00
Item 1 is secured below the playfield by: #8 X 1/2" HWH AB (Zinc) (Qty. 6) (234-5101-00)			
2	Adjustment Spindle Stop Bracket	1	535-8303-00
3	Coil Retaining Bracket	2	535-7356-00
Items 2 & 3 are secured by: #8-32 X 3/8" Swage (Serr) Zinc (Qty. 2/per) (237-5975-00)			
4	Coil, 23-1100 (ORG)	1	090-5030-00T
Coil has a Diode (1N4004) (112-5003-00) positioned @ top (above lugs next to windings).			
5	Coil Sleeve (with extension)	1	545-5847-00
6	Spring Washer, 17/32" ID X 3/4" X 1"	1	269-5002-00
7	Plunger & Shaft Assembly	1	515-6844-00

ORDERING ABOVE (ITEM 7) SUB-ASSY. PART Nº WILL INCLUDE:

7A	Ball Bumper Plastic (Top) Red	1	550-5029-02
7B*	Roll Pin, 3/32" ø X 1/2" Long	1	251-5002-00
7C*	Retaining Ring, 1/4" ø Shaft	1	270-5002-00
7D	Plunger & Shaft Sub-Assembly	1	515-6841-00
7E	Plunger Head	1	530-5511-00
7F	#10-32 X 3/8" PPH MS (Sems) Zinc	1	232-5401-00

Ordering Note: If 515-6844-00 is unavailable, order the individual part(s) actually required. Item 7D, part of Item 7, Plunger & Shaft Sub-Assembly, is 1 piece and cannot be ordered separated.

8	Compression (Relay) Spring	1	266-5022-01
9	#10-32 Adj. Spindle Stop w/Rubber Tip	1	280-5014-00
Item 9 is secured by: #10-32 Keps Nut (Qty. 1) (240-5208-00)			

Ordering Note: If 500-6293-00 is unavailable, order the individual part(s) actually required.

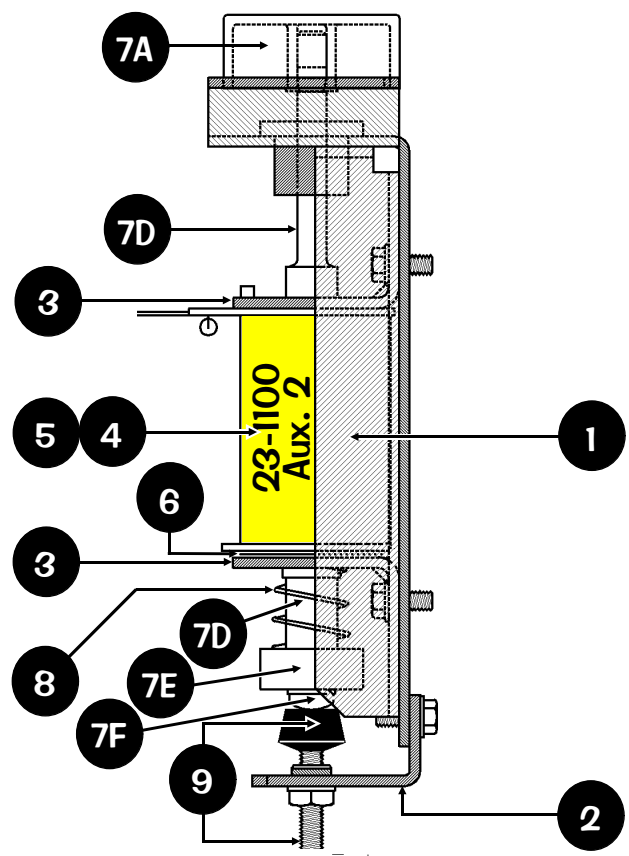

Take Note:

* An asterisk (*) indicates item(s) are not noted in the pictorials.

Sec. 4: Drawings ...



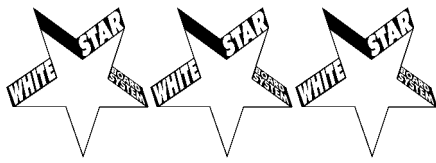

Section 5 Schematics & Troubleshooting Table of Contents

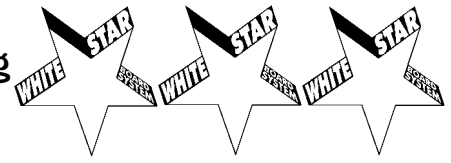

- COILS DETAILED CHART TABLE..... 100
- Chapter 1, Backbox Wiring101
 - Backbox I/O Power Driver Board Detailed Wiring Diagram..... 101
 - Backbox Board Layout Wiring Diagram 102
- Chapter 2, Playfield Wiring.....103
 - General Illumination Circuit Detailed Wiring Diagram 103
 - Playfield Switch Wiring Diagram & Playfield Lamp Wiring Diagram 104
 - Playfield Terminal Strips, Fuses & Misc. Wiring Descriptions & Locations 105
 - 5-Flipper Circuit Wiring Diagram 106
- Chapter 3, Cabinet Wiring 107
 - Transformer Power Wiring Diagram107
 - Cabinet / Coin Door Wiring Diagram 108
- Chapter 4, Printed Circuit Boards (PCBs)109
 - Trough Up-Kicker Dual OPTO Boards
Theory of Operation & Schematic, Component Layout & Parts 109
 - OPTO Troubleshooting (Top) 110
 - Trough Dual OPTO Boards Alignment / Tests for LED1 & LED2..... 110-111
 - Dot Matrix Display/Display Controller Bd. Combined Display Connections 112
 - Display Power Supply Board Schematic, Component Layout & Parts 113
 - Display Controller Board Schematic 114-115
 - Display Controller Board Component Layout & Parts 116
 - I/O Power Driver Board Theory of Operation 117
 - I/O Power Driver Board Schematic
(Sheet 1 of 5), (Sheet 2 of 5), (Sheet 3 of 5), (Sheet 4 of 5), (Sheet 5 of 5)..... 118-127
 - I/O Power Driver Board Component Layout 128
 - I/O Power Driver Board Parts 129
 - CPU/Sound Board Theory of Operation 131
 - CPU/Sound Board Schematic
(Sheet 1 of 3), (Sheet 2 of 3), (Sheet 3 of 3) 132-137
 - CPU/Sound Board Component Layout..... 138
 - CPU/Sound Board Parts 139
 - CPU/Sound Board II (with ATMEL Processor) Theory of Operation I
 - CPU/Sound Board II (with ATMEL Processor) Schematic
(Sheet 1 of 4), (Sheet 2 of 4), (Sheet 3 of 4), (Sheet 4 of 4) II-IX
 - CPU/Sound Board II (with ATMEL Processor) Component LayoutX
 - CPU/Sound Board II (with ATMEL Processor) PartsXI
 - Color Dot Display (5X7) x4 PC Board (TV Set) Component Layout 140
 - LED PC Board (Mode Signifier) Component Layout 141
 - Tournament Serial Interface Board Schematic 142-143
 - Tournament Serial Interface Board Component Layout & Parts 144

Visit www.SternPinball.com/schematics.htm for the latest 11" X 17" Schematics (or "Split 8-1/2" X 11") for the Display Power Supply, Display Controller, I/O Power Driver & CPU/Sound Boards (White Star System Only). Along with the schematics you'll find the component layout and theory of operation. Keep visiting as these files are updated. If you find a link that does not work, please let us know. If you have any questions or comments, please email us at info@sternpinball.com.
 If you have any questions or comments, please email us at info@sternpinball.com.
 If you have any questions or comments, please email us at info@sternpinball.com.
 If you have any questions or comments, please email us at info@sternpinball.com.
 If you have any questions or comments, please email us at info@sternpinball.com.

All 11 X 17 Schematics and other PDF files are also available on CD-ROM.



Use the below **Coils Detailed Chart Table** in conjunction with *Sec. 5, Chp. 1, Backbox I/O Power Driver Board Detailed Wiring Diagram (I/O Board Connectors J6, J7, J8 & J9) and Backbox Board Layout Wiring Diagram:*

COILS DETAILED CHART TABLE

High Current Coils Group 1		Drive Transistor	Driver Output Board	Power Line Color	Power Line Connection	Power Voltage	Drive Transistor Control Line Color	D.T. Control Line Connect	Coil GA-Turn or Bulb Type
#1	TROUGH UP-KICKER	Q1	▲ I/O Power Driver ▼	YEL-VIO	J10-P4/5	50v DC	BRN-BLK	J8-P1	26-1200 090-5044-00T
#2	AUTO LAUNCH	Q2		YEL-VIO	J10-P4/5	50v DC	BRN-RED	J8-P3	26-1200 090-5044-00T
#3	COUCH RELEASE	Q3		YEL-VIO	J10-P4/5	50v DC	BRN-ORG	J8-P4	28-1050 090-5046-00
#4	DROPS RESET UP	Q4		YEL-VIO	J10-P4/5	50v DC	BRN-YEL	J8-P5	26-1200 090-5044-00T
#5	ITCHY & SCRATCHY EJECT (VUK)	Q5		YEL-VIO	J10-P4/5	50v DC	BRN-GRN	J8-P6	27-1500 090-5004-00T
#6	UPPER LEFT VUK	Q6		YEL-VIO	J10-P4/5	50v DC	BRN-BLU	J8-P7	26-1200 090-5044-00B
#7	TV RELEASE	Q7		YEL-VIO	J10-P4/5	50v DC	BRN-VIO	J8-P8	28-1050 090-5046-00
#8	HOMER HEAD	Q8		GRY-3A Fuse-BRN	J7-P1	20v DC	BRN-GRY	J8-P9	22-900 090-5020-20T
High Current Coils Group 2		Drive Transistor	Driver Output Board	Power Line Color	Power Line Connection	Power Voltage	Drive Transistor Control Line Color	D.T. Control Line Connect	Coil GA-Turn or Bulb Type
#9	LEFT BUMPER	Q9	▲ I/O Power Driver ▼	YEL-VIO	J10-P4/5	50v DC	BLU-BRN	J9-P1	26-1200 090-5044-00T
#10	RIGHT BUMPER	Q10		YEL-VIO	J10-P4/5	50v DC	BLU-RED	J9-P2	26-1200 090-5044-00T
#11	BOTTOM BUMPER	Q11		YEL-VIO	J10-P4/5	50v DC	BLU-ORG	J9-P4	26-1200 090-5044-00T
#12	UPF LEFT FLIPPER	Q12		GRY-3A Fuse-RED-YEL	J10-P1/2	50v DC	BLU-YEL	J9-P5	25-1800 090-5041-00T
#13	UPF RIGHT FLIPPER	Q13		BLU-YEL-3A Fuse-RED-YEL	J10-P1/2	50v DC	BLU-GRN	J9-P6	24-1570 090-5025-00T
#14	TOP RIGHT FLIPPER	Q14		BLU-YEL-3A Fuse-RED-YEL	J10-P1/2	50v DC	BLU-BLK	J9-P7	23-1100 090-5030-00T
#15	LEFT FLIPPER (50v RED/YEL)	Q15		GRY-YEL-3A Fuse-RED-YEL	J10-P1/2	50v DC	ORG-GRY	J9-P8	22-1080 090-5032-00T
#16	RIGHT FLIPPER (50v RED/YEL)	Q16		BLU-YEL-3A Fuse-RED-YEL	J10-P1/2	50v DC	ORG-VIO	J9-P9	22-1080 090-5032-00T
Low Current Coils Group 1		Drive Transistor	Driver Output Board	Power Line Color	Power Line Connection	Power Voltage	Drive Transistor Control Line Color	D.T. Control Line Connect	Coil GA-Turn or Bulb Type
#17	LEFT SLINGSHOT	Q17	▲ I/O Power Driver ▼	BRN	J7-P1	20v DC	VIO-BRN	J7-P2	23-800 090-5001-00T
#18	RIGHT SLINGSHOT	Q18		BRN	J7-P1	20v DC	VIO-RED	J7-P3	23-800 090-5001-00T
#19	UPPER RIGHT EJECT	Q19		BRN	J7-P1	20v DC	VIO-ORG	J7-P4	26-1200 090-5044-00T
#20	GARAGE DOOR (EJECT)	Q20		BRN	J7-P1	20v DC	VIO-YEL	J7-P6	26-1200 090-5044-00T
#21	FLASH: POPS CLEAR	Q21		ORG	J6-P10	20v DC	VIO-GRN	J7-P7	#906 Bulb 165-5004-00
#22	FLASH: R.RAMP RED	Q22		ORG	J6-P10	20v DC	VIO-BLU	J7-P8	#906 Bulb 165-5004-00
#23	FLASH: R.RAMP ORANGE	Q23		ORG	J6-P10	20v DC	VIO-BLK	J7-P9	#906 Bulb 165-5004-00
#24	OPTIONAL COIL	Q24		RED	J16-P7	5v DC	VIO-GRY	J7-P10	Opt. 5v
Diode On Terminal Strip (if noted)									
Low Current Coils Group 2		Drive Transistor	Driver Output Board	Power Line Color	Power Line Connection	Power Voltage	Drive Transistor Control Line Color	D.T. Control Line Connect	Coil GA-Turn or Bulb Type
#25	FLASH: ITCHY	Q25	▲ I/O Power Driver ▼	ORG	J6-P10	20v DC	BLK-BRN	J6-P1	#906 Bulb 165-5004-00
#26	FLASH: SCRATCHY	Q26		ORG	J6-P10	20v DC	BLK-RED	J6-P2	#906 Bulb 165-5004-00
#27	FLASH: HOMER HEAD	Q27		ORG	J6-P10	20v DC	BLK-ORG	J6-P3	#906 Bulb 165-5004-00
#28	FLASH: COUCH	Q28		ORG	J6-P10	20v DC	BLK-YEL	J6-P4	#906 Bulb 165-5004-00
#29	FLASH: COMIC BOOK GUY	Q29		ORG	J6-P10	20v DC	BLK-GRN	J6-P5	#906 Bulb 165-5004-00
#30	DROP BANK TRIPS	Q30		BRN	J7-P1	20v DC	BLK-BLU	J6-P6	32-1250 515-6916-01
#31	FLASH: UPF ORANGE	Q31		ORG	J6-P10	20v DC	BLK-VIO	J6-P7	#906 Bulb 165-5004-00
#32	FLASH: UPF RED	Q32		ORG	J6-P10	20v DC	BLK-GRY	J6-P8	#906 Bulb 165-5004-00
Note: In Test Flash Lamps Menu ("Flash" Icon), Flashers tested are all Flash Lamps located between Q1-Q32 (This Game: Q21-Q23, Q25-Q29, Q31-Q32)									
Auxiliary (UK ONLY)		Drive Transistor	Driver Output Board	Power Line Color	Power Line Connection	Power Voltage	Drive Transistor Control Line Color	D.T. Control Line Connect	Coil GA-Turn
AUX 1: LEFT UP/DOWN POST		Q1	Solenoid Expander Auxiliary	BRN	J7-P1	20v DC	WHT	CN2-P5	26-1200 090-5044-00T
AUX 2: CENTER UP/DOWN POST		Q2		BRN	J7-P1	20v DC	RED	CN2-P4	23-1100 090-5030-00T
AUX 3: RIGHT UP/DOWN POST		Q3		BRN	J7-P1	20v DC	ORG	CN2-P3	26-1200 090-5044-00T

Sec. 5: Schematics...



Backbox Wiring

Backbox I/O Power Driver Board Detailed Wiring Diagram

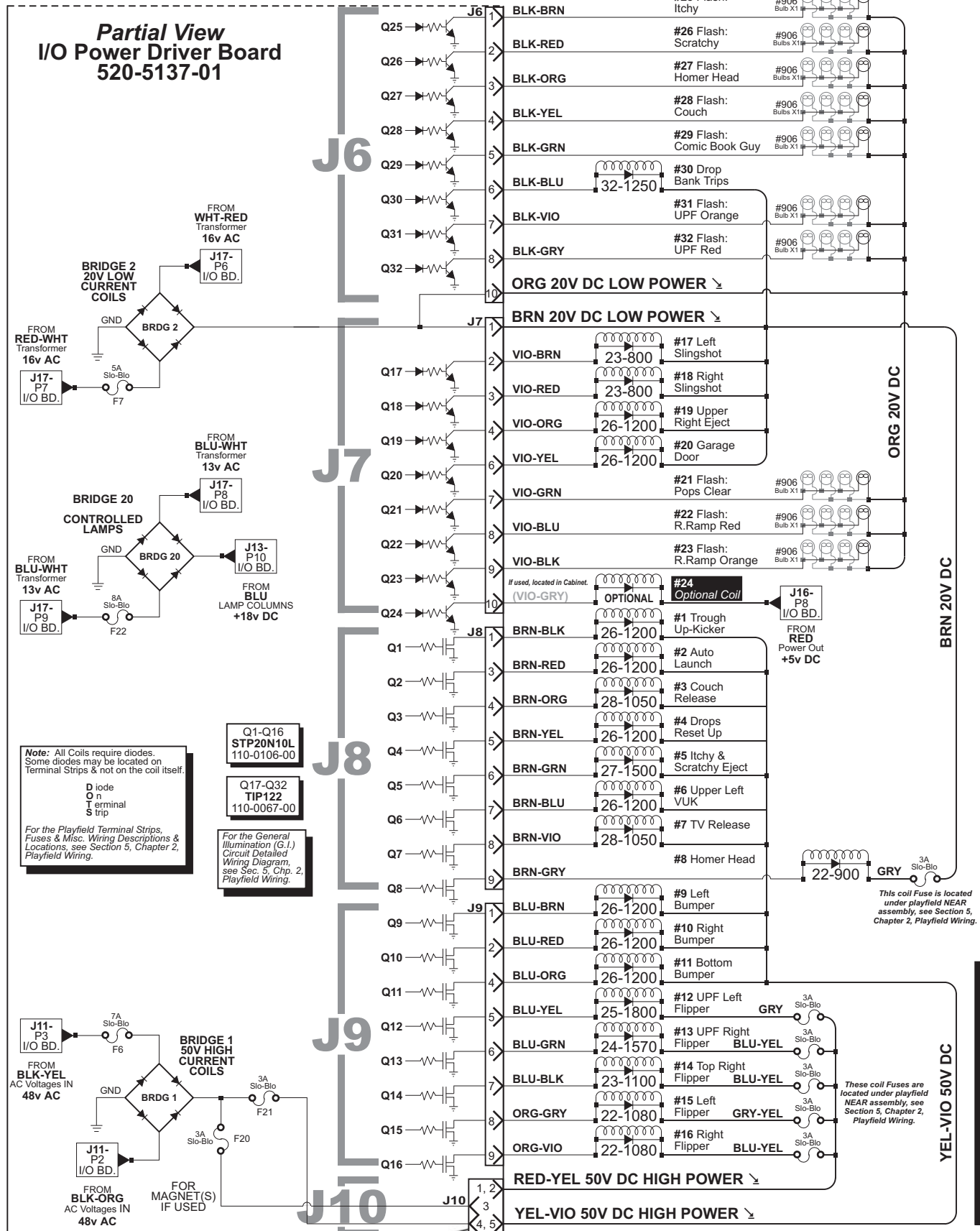

Backbox Board Layout Wiring Diagram

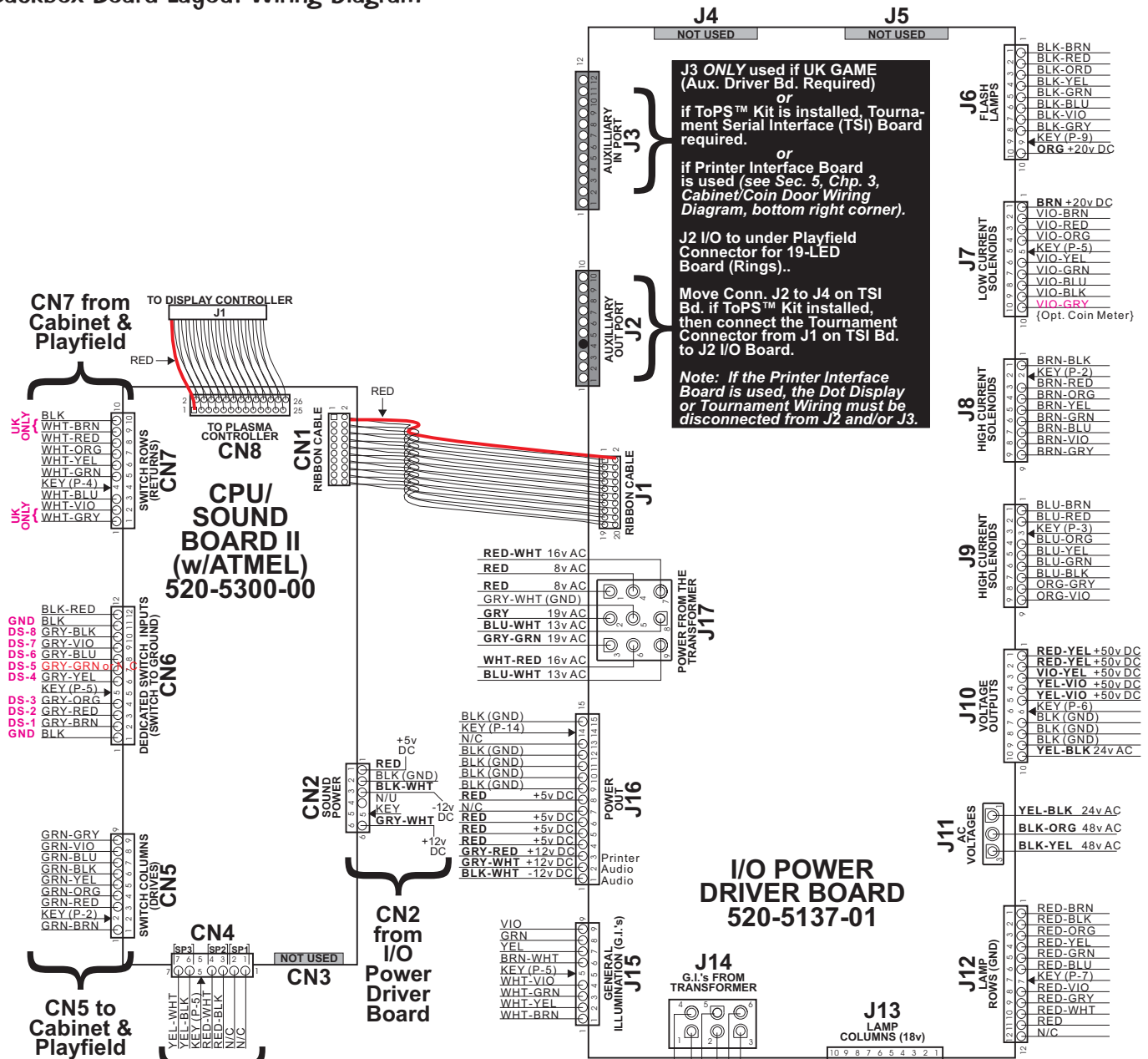

Important: When connecting any Ribbon Cable, always ensure the "Red Line" side of the ribbon cable goes to the Pin-1 side of any Dual 0.1" Header Connector.

Sec. 5: Backbox ...

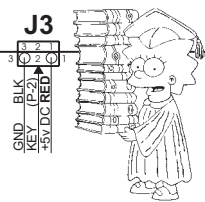
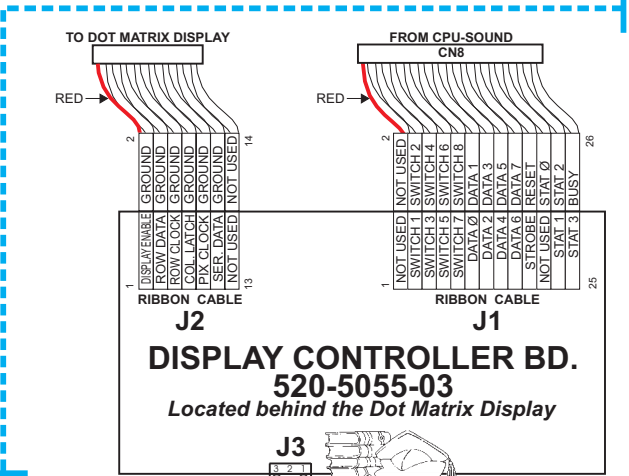
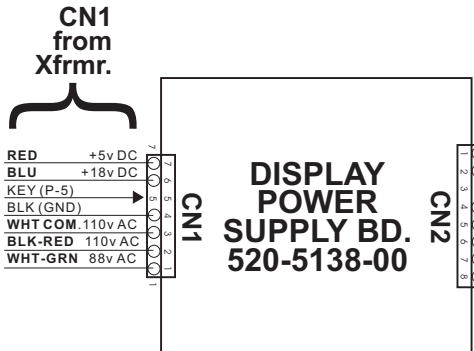

Playfield Wiring

General Illumination Circuit Detailed Wiring Diagram

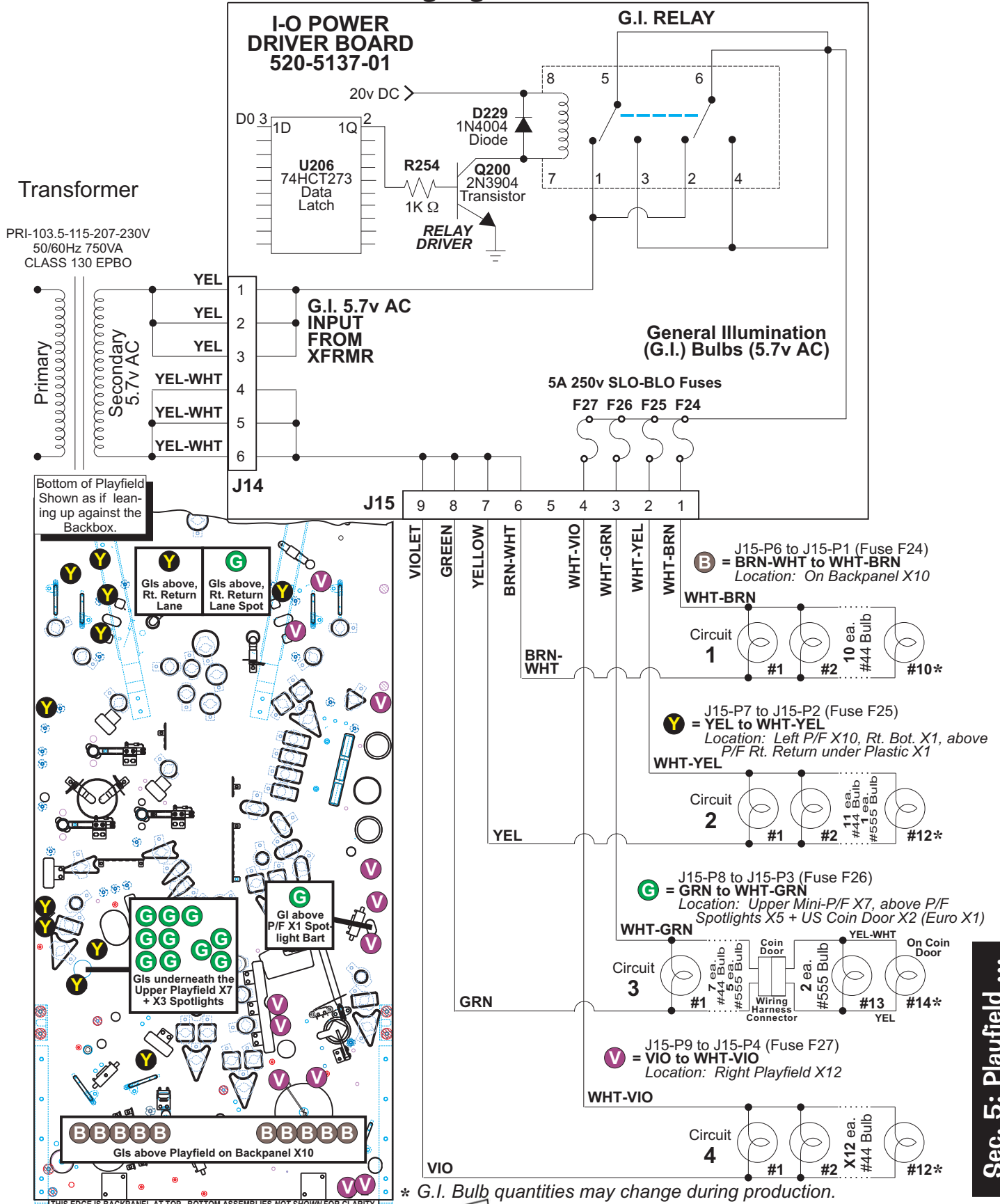

Sec. 5: Playfield ...



Playfield Switch Wiring Diagram

Note: All Switch, Lamp & Coil assemblies require diodes. Some diodes are located under the playfield on Terminal Strips or Diode Boards and not on the assemblies.

For Switch(es): 17-20

Diode On Terminal Strip

Diode On Diode Board

Switch Drive Transistor Source N#: 2N3904

COLUMN DRIVE	SWITCH DRIVE Wire & Transistor	CN5 PIN
1	GRN-BRN Q1	1
2	GRN-RED Q2	3
3	GRN-ORG Q3	4
4	GRN-YEL Q4	5
5	GRN-BLK Q5	6
6	GRN-BLU Q6	7
7	GRN-VIO Q7	8
8	GRN-GRY Q8	9

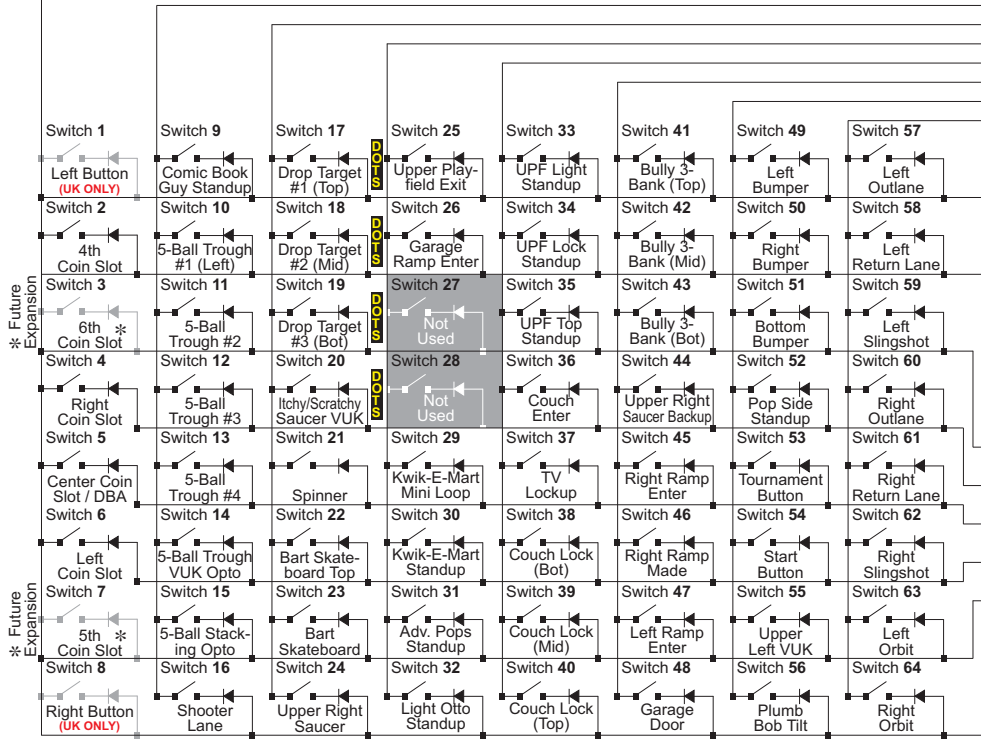

ROW RETURN	CPU/Sound Board	SWITCH RETURN Wire & IC	CN7 PIN
	N/C		10
1	WHT-BRN U400		9
2	WHT-RED U400		8
3	WHT-ORG U400		7
4	WHT-YEL U400		6
5	WHT-GRN U401		5
6	WHT-BLU U401		3
7	WHT-VIO U401		2
8	WHT-GRY U401		1

Playfield Lamp Wiring Diagram

Please Note: Switch & Lamp Descriptions may differ slightly than that of the Dot Display due to space restraints.

Note: All Switch, Lamp & Coil assemblies require diodes. Some diodes are located under the playfield on Terminal Strips or Diode Boards and not on the assemblies.

For Lamp(s): 17-19, 31 & 65-70

Diode On Terminal Strip

Diode On Diode Board

J13-Pin 10 is Power Out for +18v DC to the Display Power Supply Bd at CN1-Pin 6

COLUMN DRIVE	LAMP DRIVE Wire & IC	J13 PIN
1	YEL-BRN U17	9
2	YEL-RED U16	8
3	YEL-ORG U15	7
4	YEL-BLK U14	6
5	YEL-GRN U13	5
6	YEL-BLU U12	4
7	YEL-VIO U11	3
8	YEL-GRY U10	1

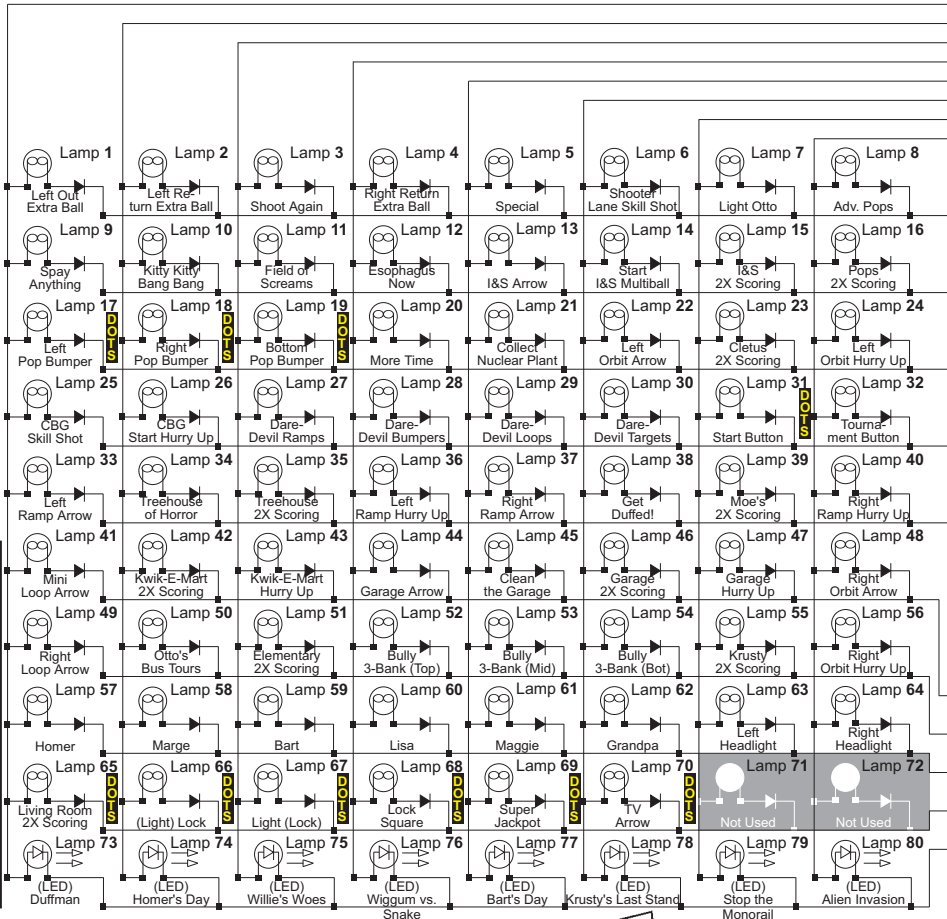

ROW RETURN	I/O Power Driver Board	LAMP RETURN Wire & Transistor	J12 PIN
			10
1	RED-BRN Q33		1
2	RED-BLK Q34		2
3	RED-ORG Q35		3
4	RED-YEL Q36		4
5	RED-GRN Q37		5
6	RED-BLU Q38		6
7	RED-VIO Q39		8
8	RED-GRY Q40		9
9	RED-WHT Q41		10
10	RED Q42		11
	N/C		12

Sec. 5: Playfield ...



Playfield Terminal Strips, Fuses & Misc. Wiring Descriptions & Locations

Please Note: Terminal Strip(s), Diode Board(s) and/or Fuse Holder(s) locations shown, represent the general location (your game may differ slightly).

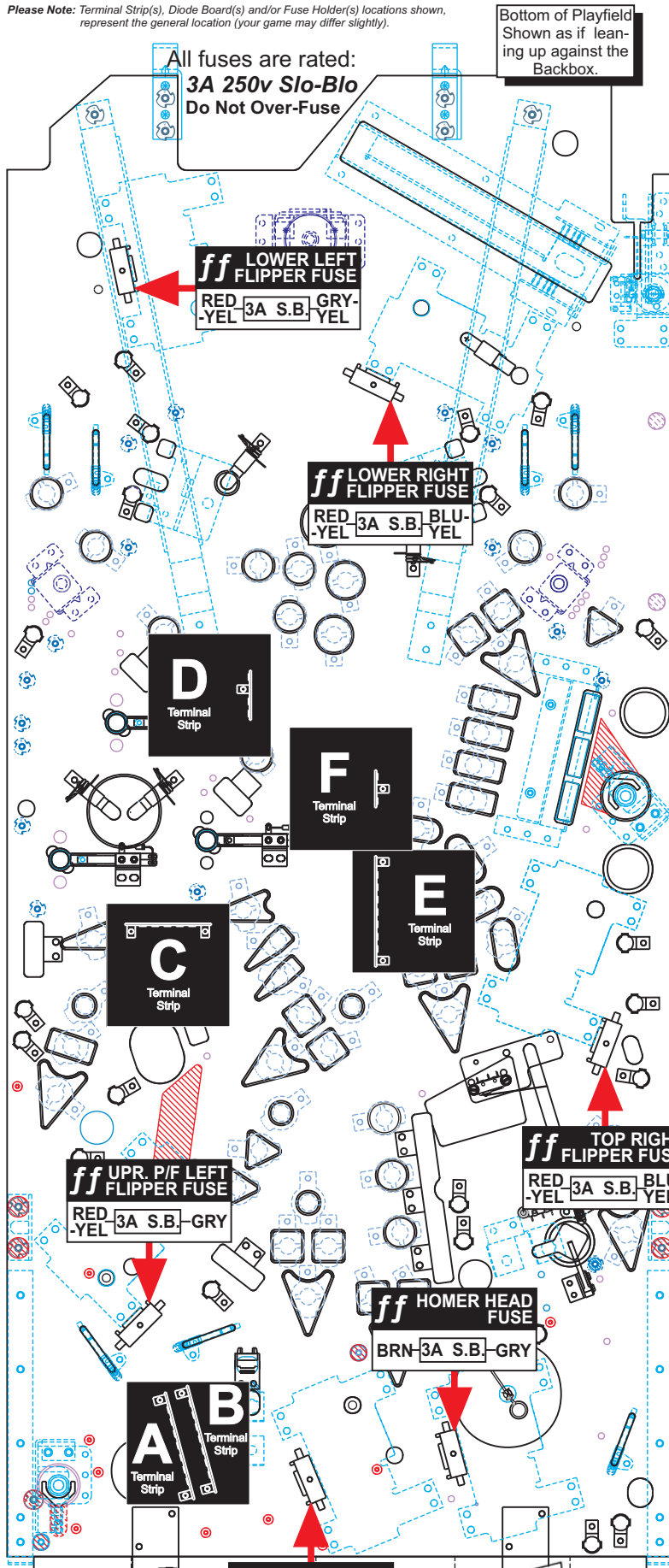

Explanation:

All Switch, Lamp & Coil assemblies require diodes. Some diodes are **located under the playfield** on Terminal Strips **or** Diode Boards and not on the assemblies. The Switch and Lamp Matrix Grids also note which Switch or Lamp has a diode on a Terminal Strip (noted by **"DOTS"** meaning: **"Diode On Terminal Strip"**) or on a Diode Board (noted by **"DODB"** meaning: **"Diode On Diode Board"**).

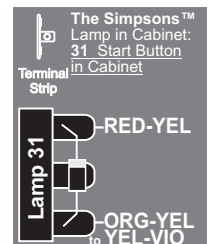
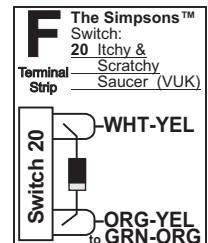
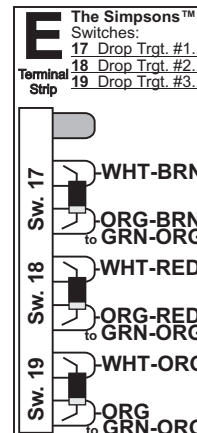
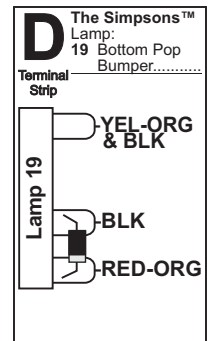
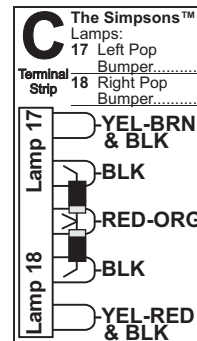
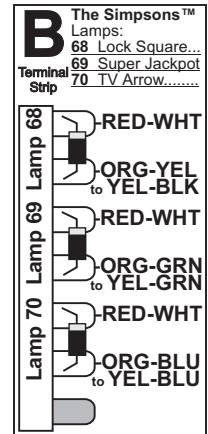
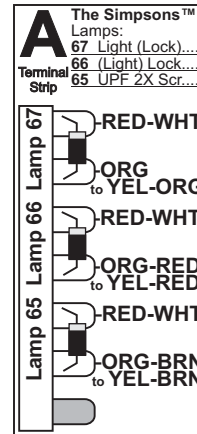

See the Pink Pages, Playfield - General Parts (Below) (Pg. 64) for Terminal Strips, Diodes, Fuses and Fuse Holders Part N^os.



5- Flipper Circuit Wiring Diagram

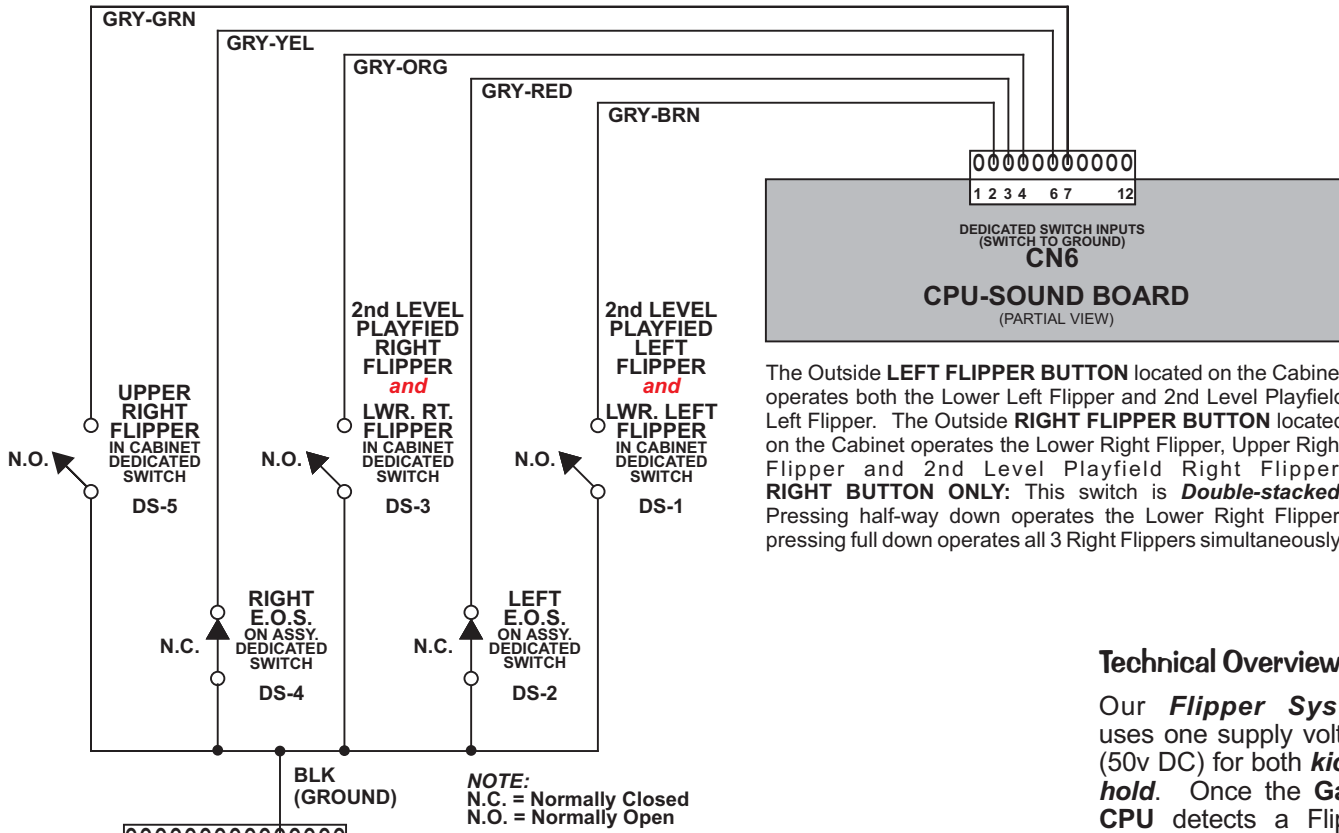

The Outside **LEFT FLIPPER BUTTON** located on the Cabinet operates both the Lower Left Flipper and 2nd Level Playfield Left Flipper. The Outside **RIGHT FLIPPER BUTTON** located on the Cabinet operates the Lower Right Flipper, Upper Right Flipper and 2nd Level Playfield Right Flipper. **RIGHT BUTTON ONLY:** This switch is **Double-stacked**. Pressing half-way down operates the Lower Right Flipper; pressing full down operates all 3 Right Flippers simultaneously.

Technical Overview

Our **Flipper System** uses one supply voltage (50v DC) for both **kick & hold**. Once the **Game CPU** detects a Flipper Cabinet Switch closure (during game play) it applies a 40msec pulse to the gate of the Flipper Drive Transistor (STP-20N10L). If it continues to detect a Flipper Cabinet Switch closure (the player holding the button in) it will continue to pulse the flipper drive transistor 1msec every 12msecs for the duration of the hold cycle.

The **E.O.S. (End-Of-Stroke) Switch** serves the same function as before as it prevents foldback when the player has the flipper energized to capture balls. The **E.O.S. Switch** is a normally closed switch which opens approximately 1/16" when the flipper is energized. The **Game CPU** will detect a switch closure if the flipper bat is forced back by a high velocity shot or rebound on the playfield and will apply another 40msec pulse of 50v DC to the coil.

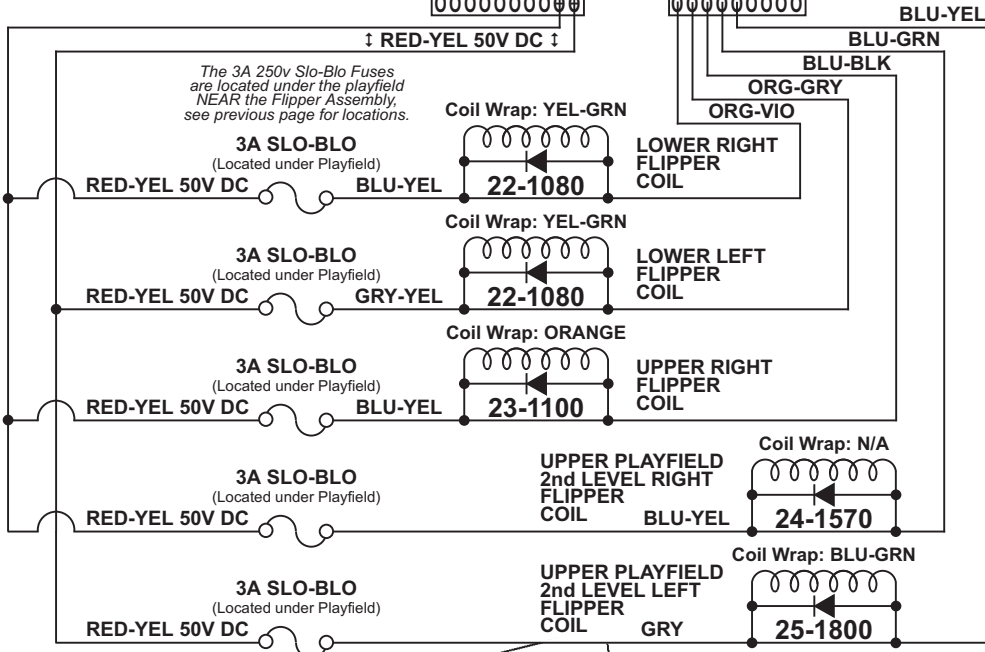
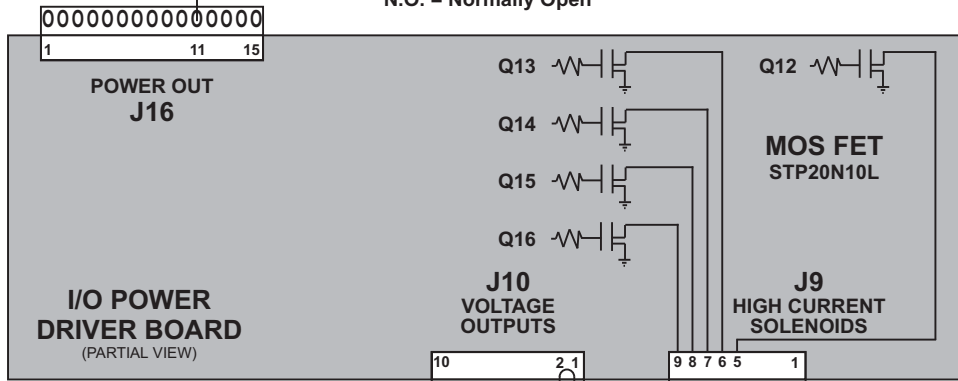

Sec. 5: Playfield ...

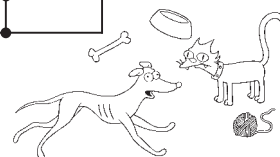

Cabinet Wiring

Transformer Power Wiring Diagram

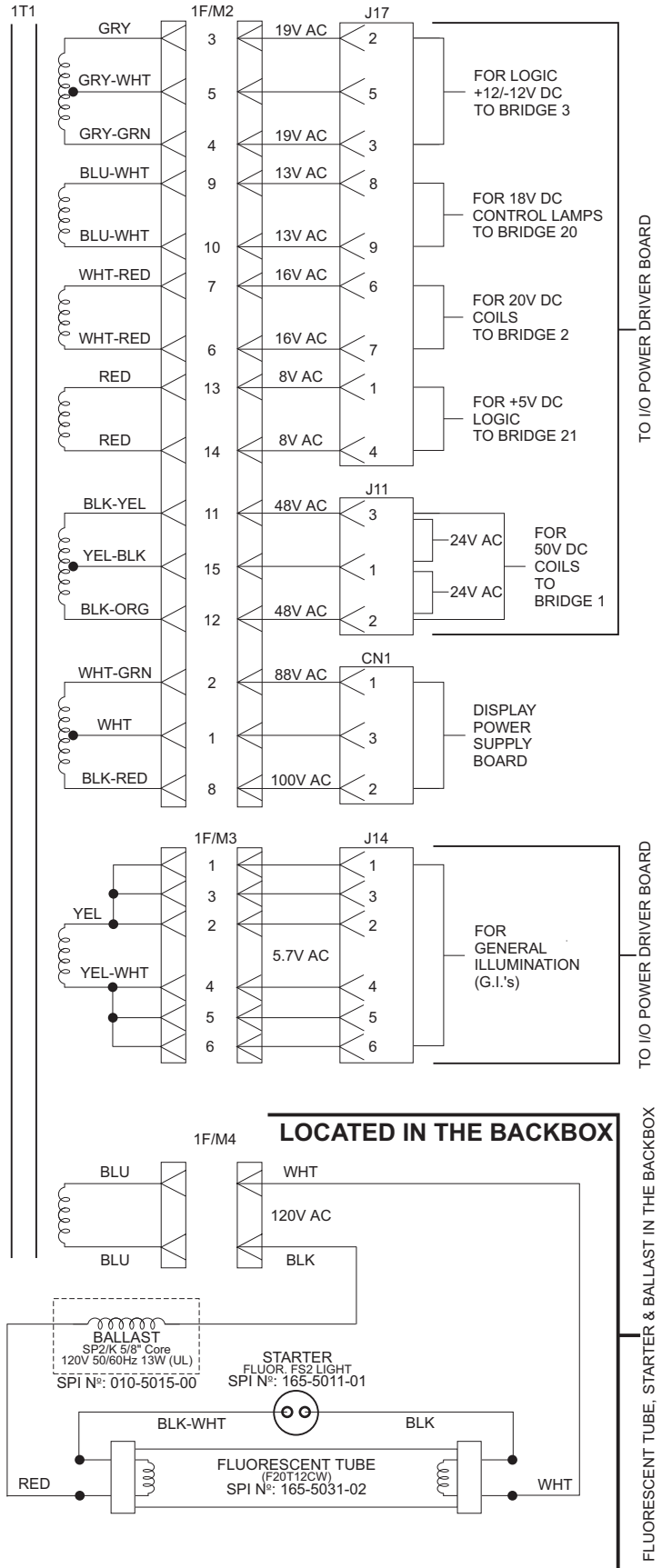
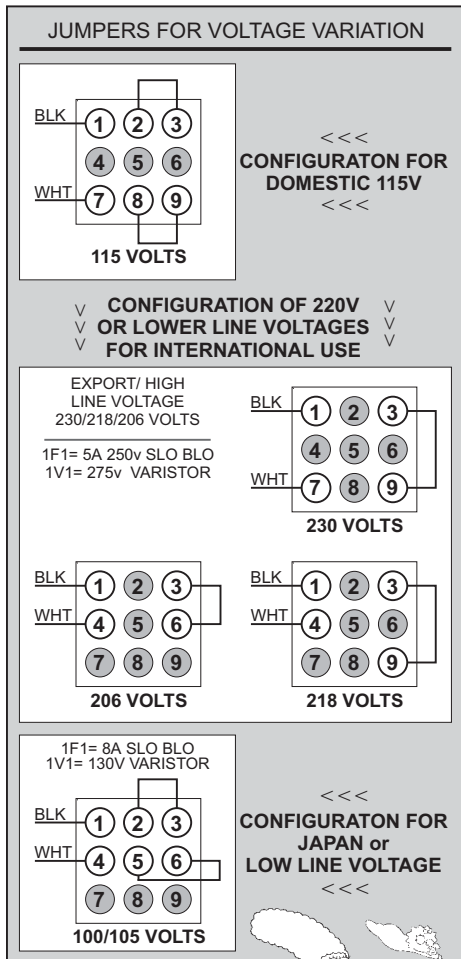
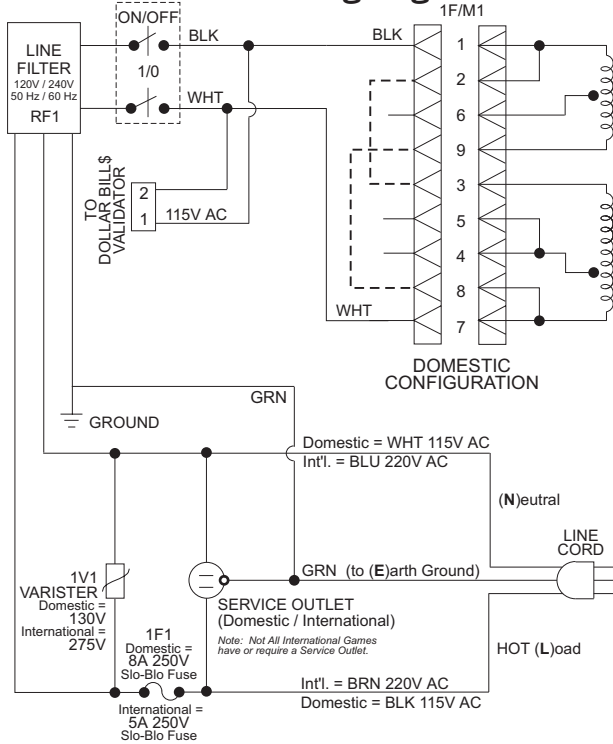

Cabinet / Coin Door Wiring Diagram

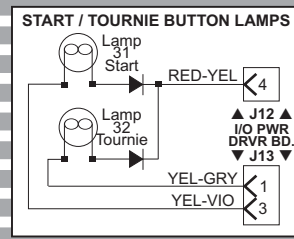
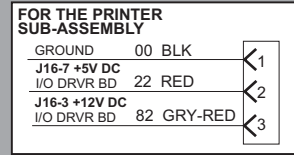
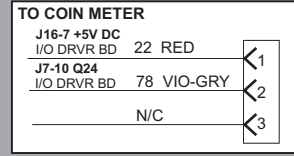
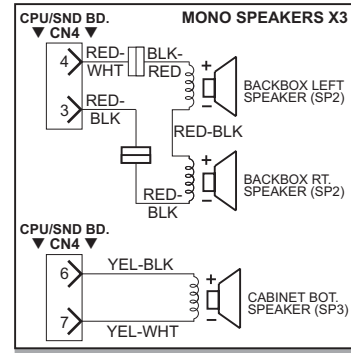
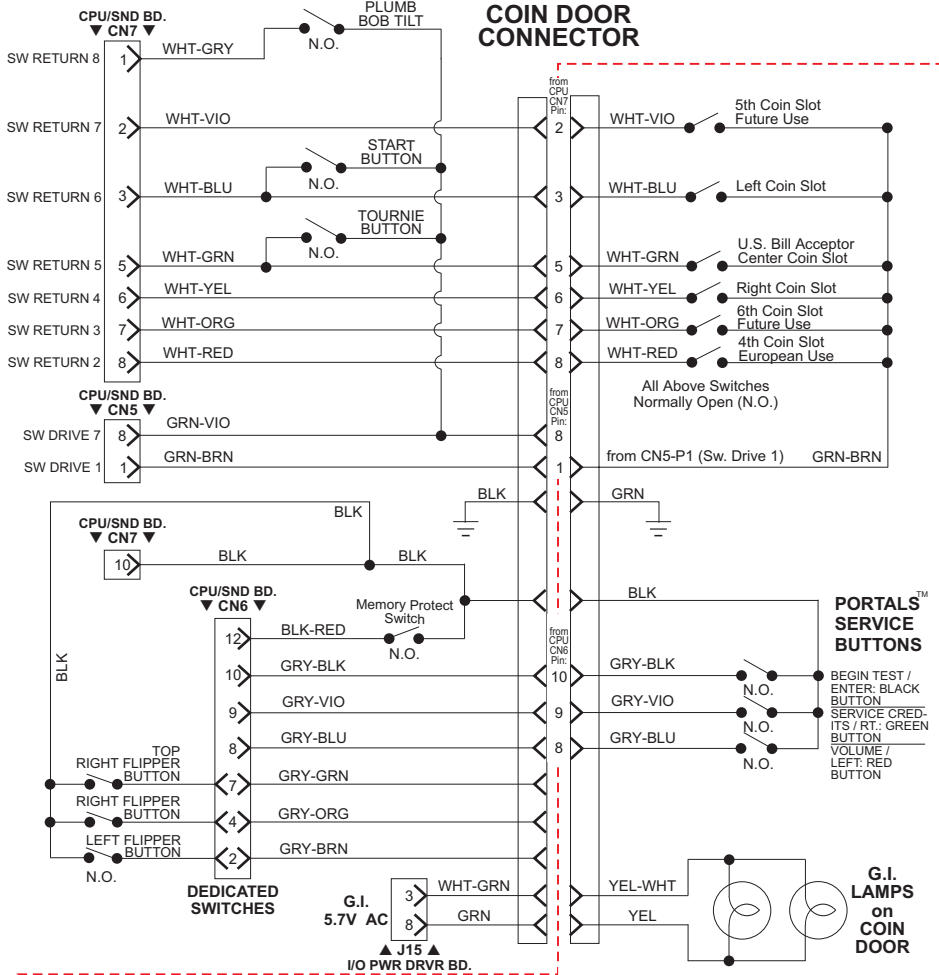

UK ONLY: 2 Extra Cabinet Buttons for the Post Save™ Feature are used. The Left Button operates the Left Outlane Ball Deflector. The Right Button operates the Right Outlane Ball Deflector. Both buttons pushed together operate the Center Up/Down Post. Both buttons are located under the Flipper Buttons.

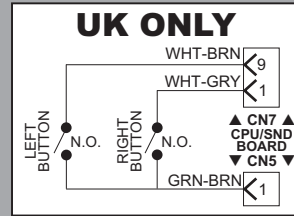

PRINTER INTERFACE OPTIONAL

Cable Wiring Harness SPI Part N°:
036-5408-00
RS-232 Printer Interface Board SPI Part N°:
520-5069-00

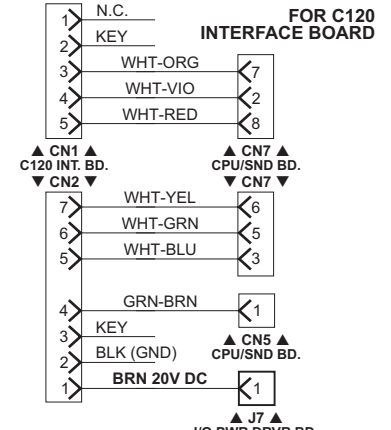
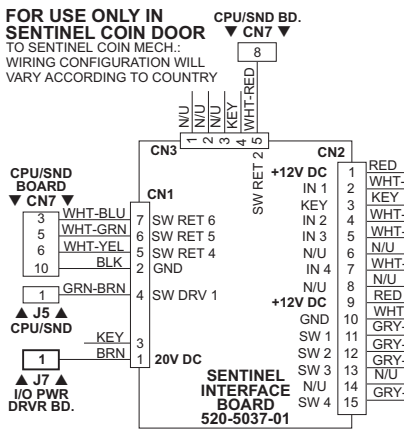
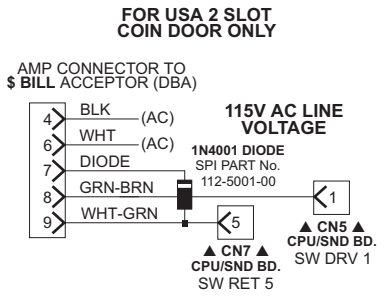
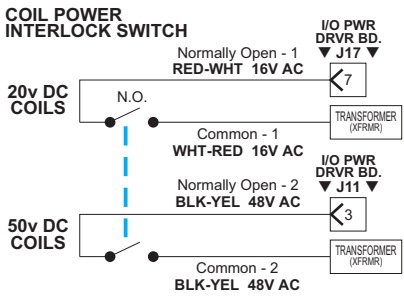
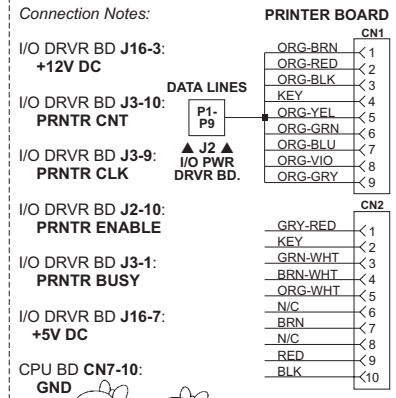

COIN DOOR

Sec. 5: Cabinet ...

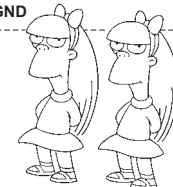

Printed Circuit Boards (PCBs)

Trough Up-Kicker Dual OPTO Boards Theory of Operation & Schematic

As light from the **Transmitter LED1** falls on the **Receiver LED1**, it generates a Positive Bias Voltage (0.7v to 1.5v) which is applied to the **Gate (G)** of **Q1 (Fet 2N5460)** turning **Q1** off. When **Q1** is held off, no current flows through **Q2's (2N3906) Base (B)**. With no *base current*, **Q2** is off and acts as an **OPEN SWITCH**. When the light is interrupted (**BLOCKED**) **R1 (Rec. Bd.)** bleeds the gate voltage off of **Q1** allowing it to conduct, switching **Q2** on, which acts as a **CLOSED SWITCH**. The **LED2 (Trans/Rec) Circuit** operates identical as the **LED1 Circuit**.

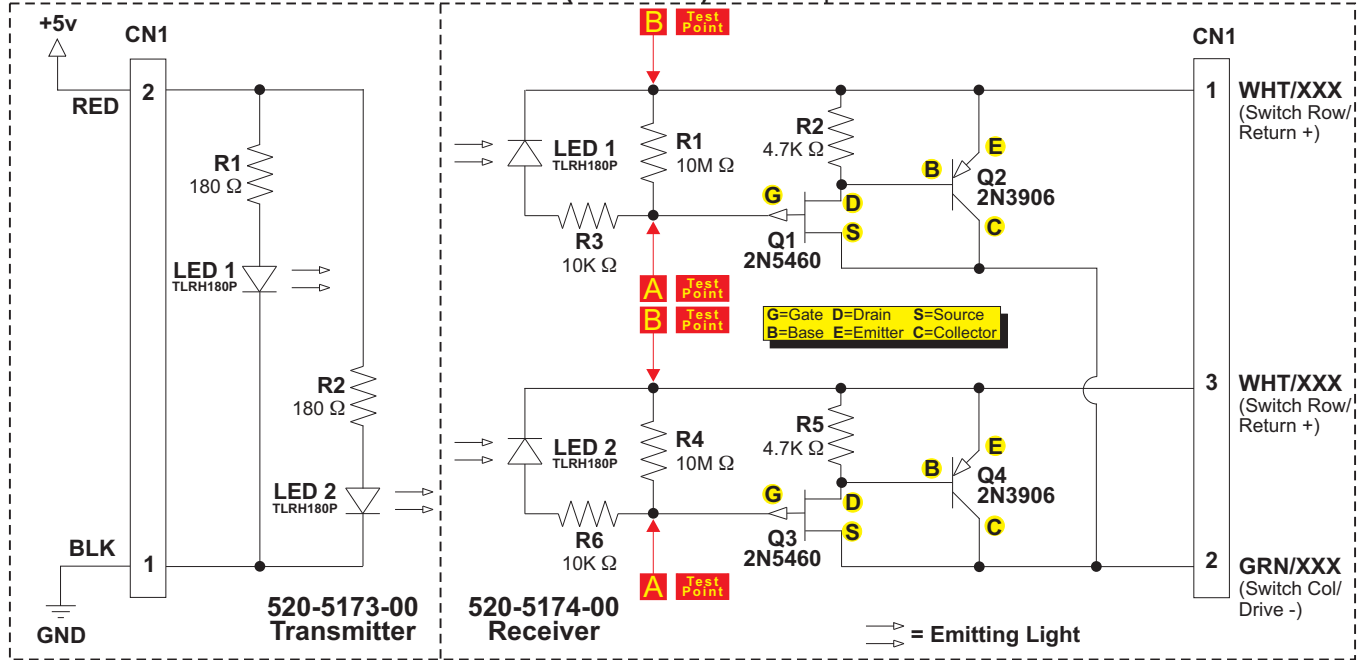

Trough Up-Kicker Dual OPTO Boards Component Layout & Parts

520-5173-00 (TRANS)

Boards Actual Size

520-5174-00 (REC)

(Screened Text Printed Larger for Clarity)

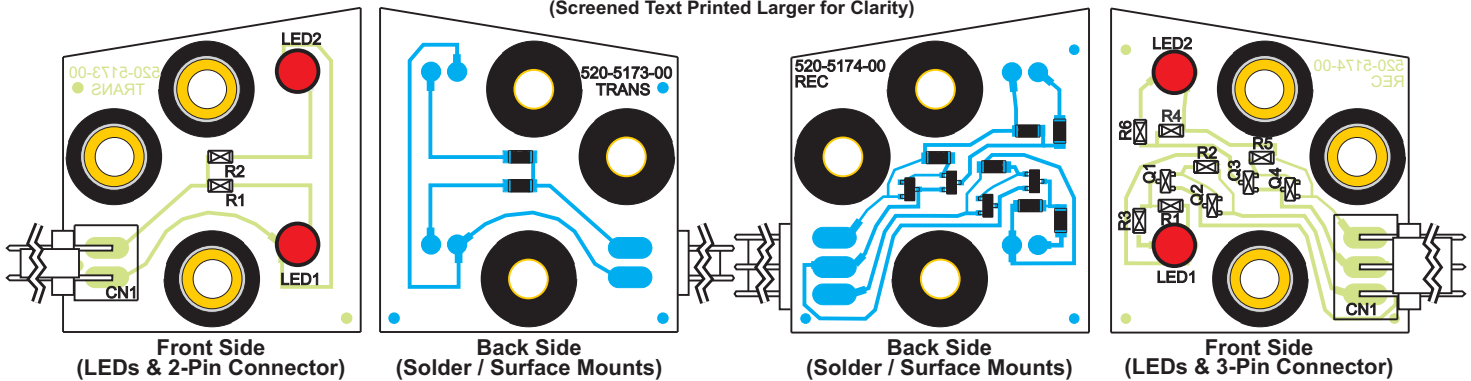

ITEM	QTY	PART NUMBER	REF-DESIGNATOR	DESCRIPTION
A	1	515-0173-00	Dual-OPTO Trans. Bd. Assy.	PCB Assy. (with all Items 1-5)
—	1	520-5173-00	Dual-OPTO Trans. Board	PCB Assy. (with Items 1-3 only)
01	1	045-5111-02	CN1	2X, .156" Rt. Angle (26-60-5020) Conn.
02	2	165-5052-00	LED1, LED2	LED TLRH180P (Ultra Bright Red)
03	2	121-5067-00	R1, R2	180 Ω 1/8W Chip Res. (CRCW)
04	3	530-5308-02	n/a	OPTO PCB Brass Tube Spacer
05	3	545-5518-00	n/a	OPTO PCB Rubber Grommet
B	1	515-0174-00	Dual-OPTO Rec. Bd. Assy.	PCB Assy. (with all Items 1-9)
—	1	520-5174-00	Dual-OPTO Rec. Board	PCB Assy. (with Items 1-7 only)
01	1	045-5111-03	CN1	3X, .156" Rt. Angle (26-60-5030) Conn.
02	2	165-5052-00	LED 1, LED 2	LED TLRH180P (Ultra Bright Red)
03	2	110-5006-00	Q1, Q3	2N5460, Transistor (P-FET SOT-23)
04	2	110-0086-00	Q2, Q4	2N3906, Transistor
05	2	121-5082-00	R1, R4	10M Ω 1/8W Chip Res. (CRCW)
06	2	121-5083-00	R2, R5	4.7K Ω 1/8W Chip Res. (CRCW)
07	2	121-5011-00	R3, R6	10K Ω 1/8W Chip Res. (CRCW)
08	3	530-5308-02	n/a	OPTO PCB Brass Tube Spacer
09	3	545-5518-00	n/a	OPTO PCB Rubber Grommet

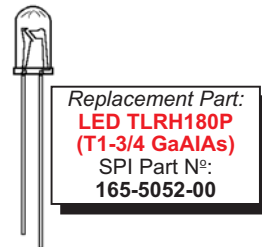

OPTO Troubleshooting

1. Volt Meter Test (indicates normal operating condition):

A. **OPEN OPTO** (Light Falling on LED) = **SWITCH OPEN**. Place meter leads across points **A** and **B** on the **LED1 Circuit** (Refer to Schematic Drawing on previous page, 520-5174-00 Receiver Side). It should read approximately 0.8 - 1.2v DC. The **LED2 Circuit** operates the same.

B. **CLOSED OPTO** (Light Blocked) = **SWITCH CLOSED**. Place meter leads across points **A** and **B** on the **LED1 Circuit** (Refer to Schematic Drawing on previous page, 520-5174-00 Receiver Side). It should read approximately 0.0 - 0.1v DC. The **LED2 Circuit** operates the same.

2. Oscilloscope Test (indicates normal operating condition):

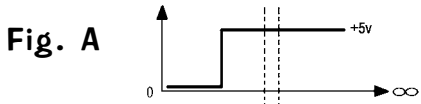

A. **OPEN OPTO** (Light Falling on LED) = **SWITCH OPEN**. Place Scope lead at **Pin-1** of OPTO Rec. Board with Scope Grounded (see Schematic). The Scope should display a **STEADY +5v** as shown in **Fig. A**, Wave Form Diagram.

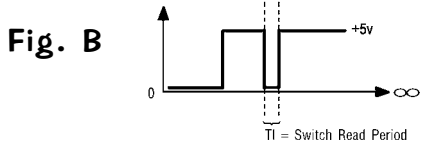

B. **CLOSED OPTO** (Light Blocked) = **SWITCH CLOSED**. Place Scope lead at **Pin-1** of OPTO Rec. Board with Scope Grounded (see Schematic). The Scope should display a **PULSE STREAM** indicating **Q2** has switched "On" as shown in **Fig. B**, Wave Form Diagram. This is your Switch Drive Pulse.

3. Bench Test (See Fig. C):

Please Note: To perform this test you must use a spare 560Ω Pull-Up Resistor, SPI N^o: 121-5047-00

Disconnect the **OPTO Transmitter / Receiver Board** from the circuit. Connect one side of a 560Ω Pull-Up Resistor to **Pin-1** of the OPTO Receiver Bd. and the other side of the resistor to a 5v DC source. Connect **Pin-2** to GND. Connect a +5v DC source to **Pin-1** of the Transmitter & GND to **Pin-2**. Align with the Receiver OPTO approx. 3" distance. Using your Volt-Meter or an Oscilloscope, monitor **Pin-1** while **BLOCKING** and **UNBLOCKING** the **BEAM** from the Trans. The output will be approx. +5v DC when the **BEAM IS NOT BLOCKED** and approx. 0v when the **BEAM IS BLOCKED**.

Fig. C

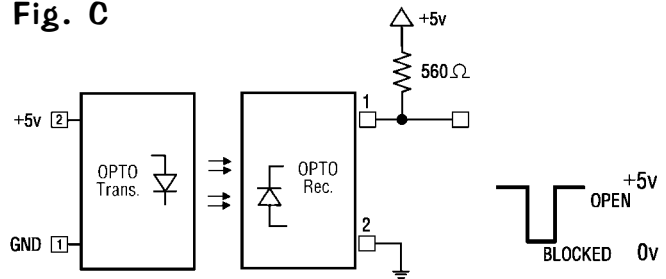

Trough Dual OPTO Boards Alignment / Test for LED1

When a working **OPTO** is installed and connected in a game, the transmitter should light (LED1 lower & LED2 upper) when the power is switched on. With the playfield in **Service Position #1** (playfield lifted up in the half-way position resting on the Prop Rod or edge slide support brackets) and the game on, the LED lights should show up as a **BRIGHT RED RINGS** through the back of the Receiver Board around the **Receivers LED1 & LED2** (See **Fig. 1**). Testing only **LED1**: With the game in **Switch Test Mode**, lifting the Trough Plunger with a fingertip should block the **BEAM** and cause the Switch Position to trigger (See **Fig. 2**). View **Fig. 2a & 2b** (on the next page) for a sectional view of the Light Path (note alignment) and what happens as a ball breaks the light beam.

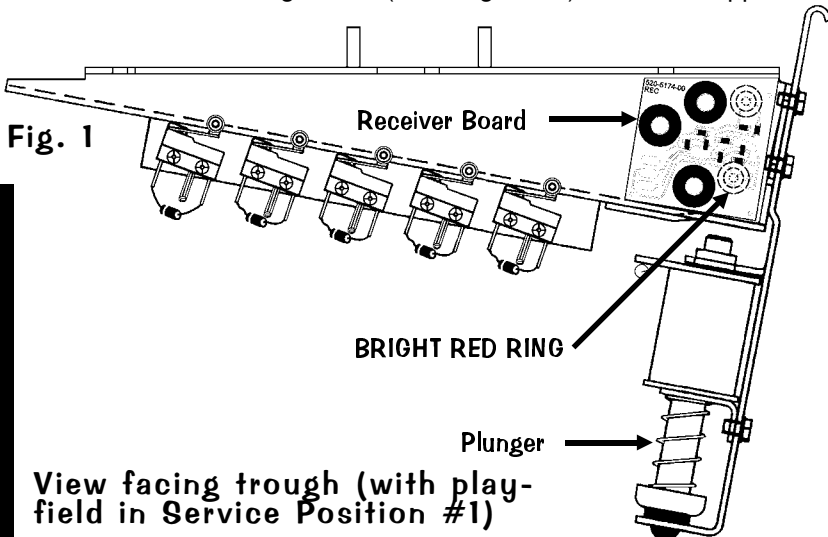
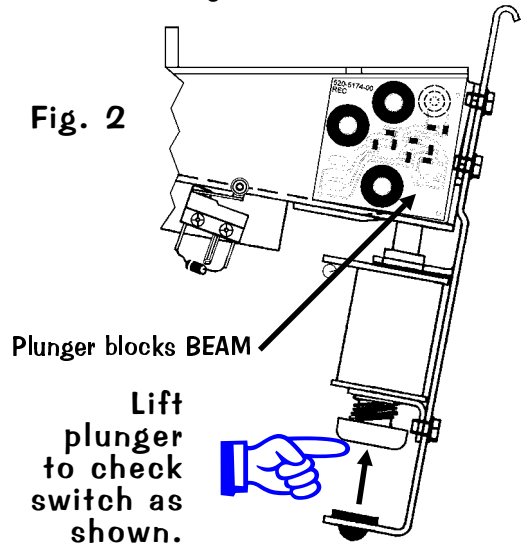
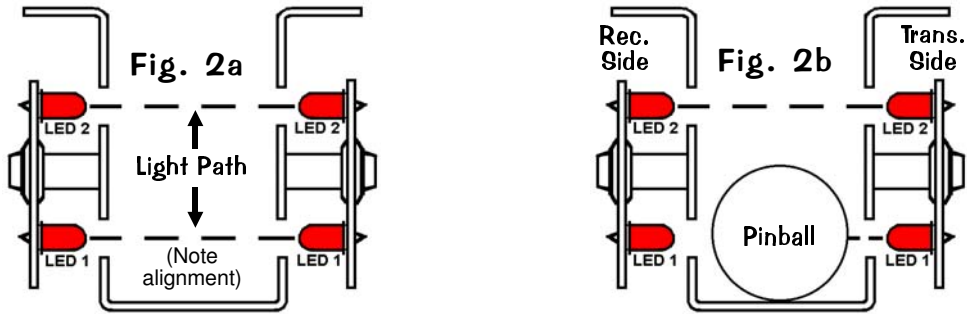

Fig. 2



Sectional view from right (Fig. 2a & 2b)



Trough Dual OPTO Boards Alignment / Test for LED2

When a working **OPTO** is installed and connected in a game, the transmitter should light (LED1 lower & LED2 upper) when the power is switched on. With the playfield in **Service Position #1** (playfield lifted up in the half-way position resting on the Prop Rod or edge slide support brackets) and the game on, the LED lights should show up as a **BRIGHT RED RINGS** through the back of the Receiver Board around the **Receivers LED1 & LED2** (See Fig. 1, previous page). Testing only **LED2**: *TO PERFORM THIS TEST, A PINBALL MUST BE IN THE BALL TROUGH.* With the game in **Switch Test Mode**, lifting the Trough Plunger with a finger tip should block the **BEAM** on LED2 and cause the Switch Position to trigger (See Fig. 3). View Fig. 3a & 3b for a sectional view of the Light Path (note alignment) and what happens as a "double-stacked" ball scenario breaks the light beam.

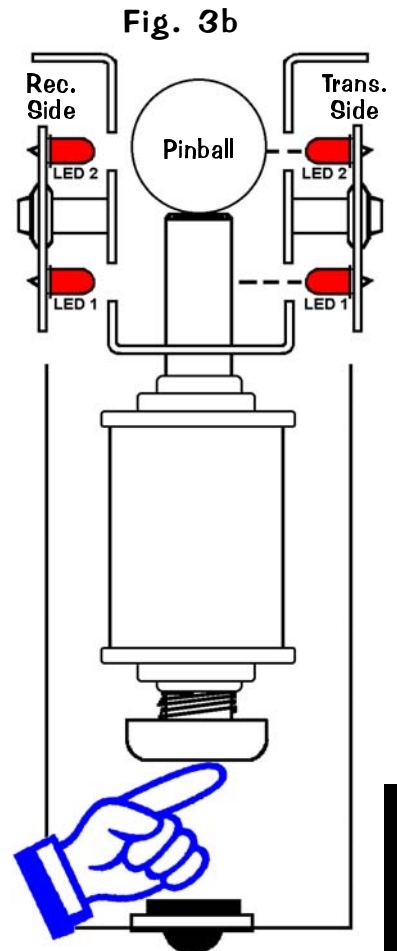
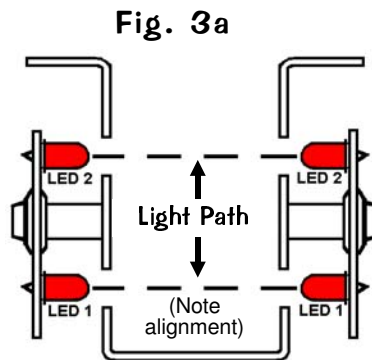
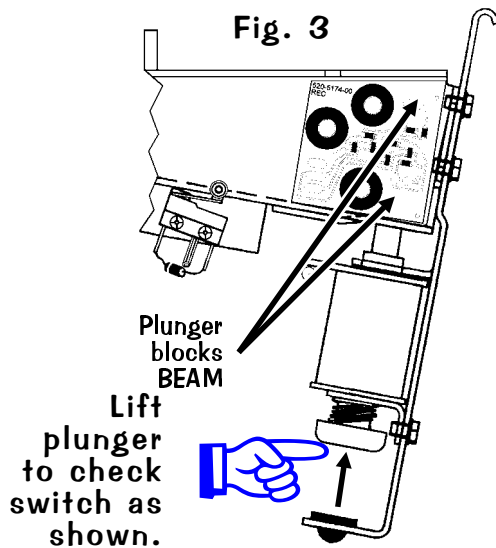

I M P O R T A N T

If replacement of **LED** is required, insure that is **mounted correctly before and after soldering** (See Fig. 4a / 4b).

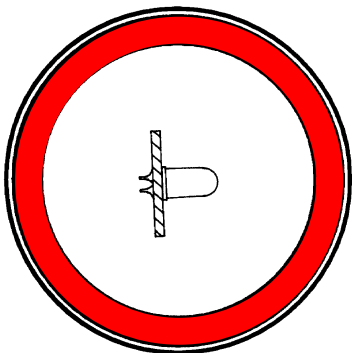

Fig. 4a
Correct Position

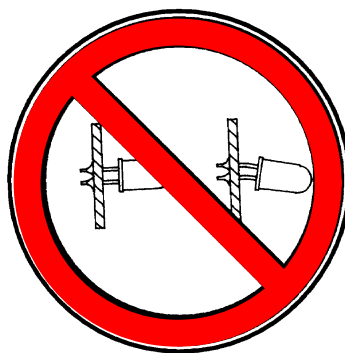
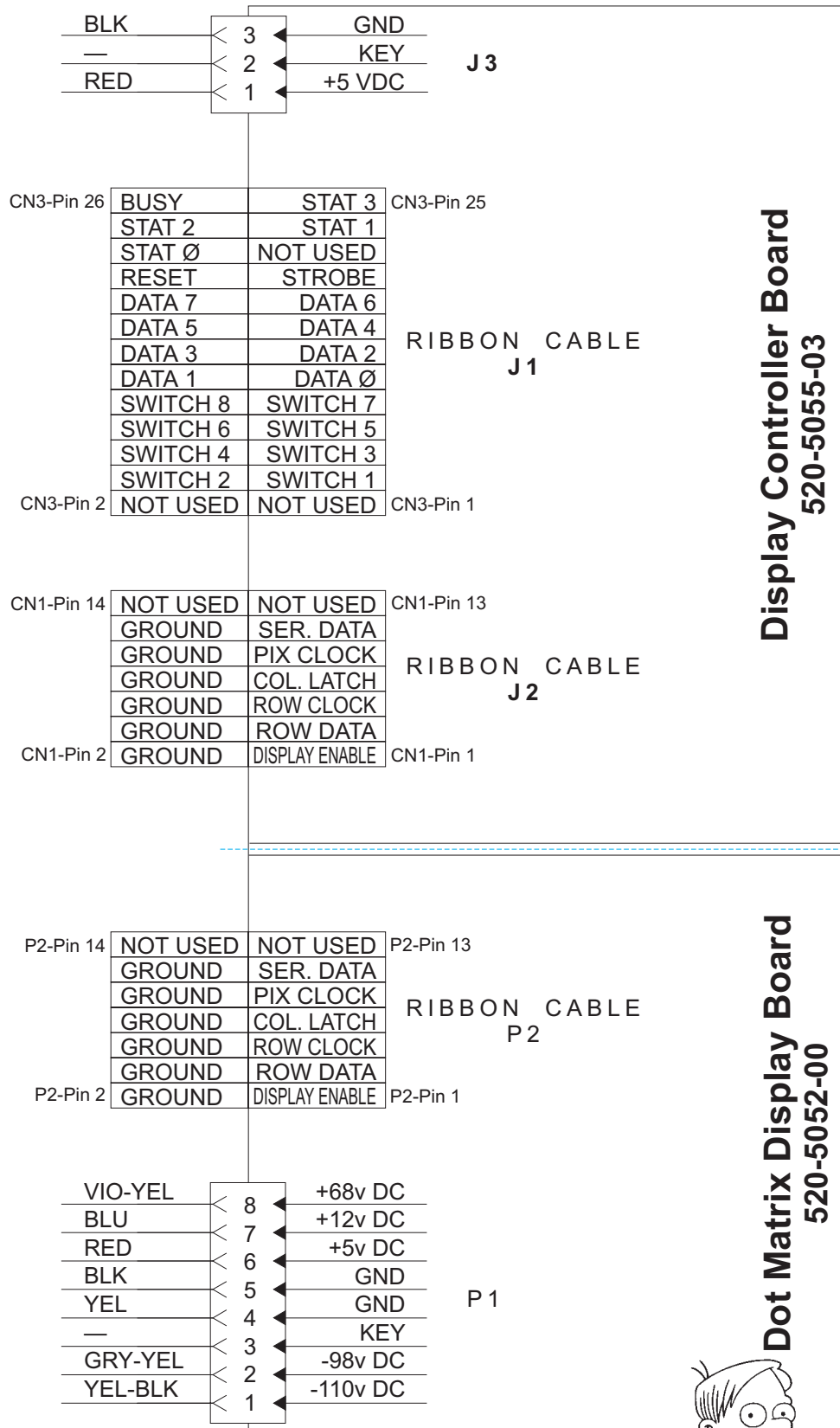

Fig. 4b
Incorrect Position



Dot Matrix Display / Display Controller Bd. Combined Display Connections



Sec. 5: PCBs



Display Power Supply Board Schematic

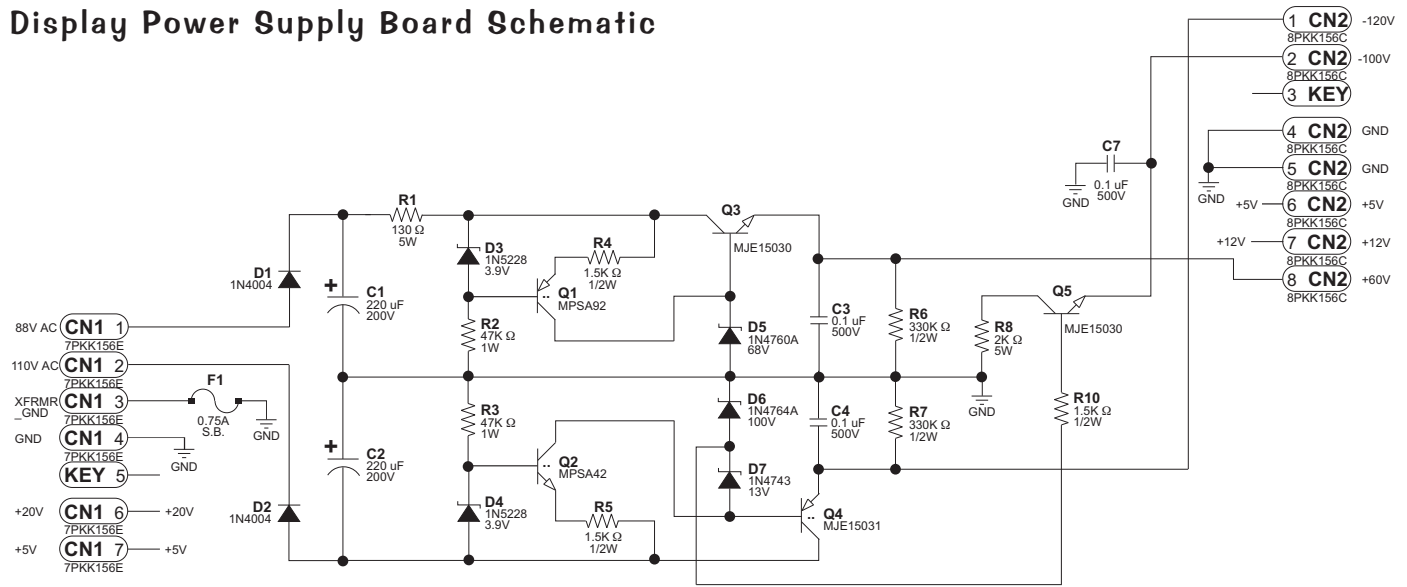

Display Power Supply Board Component Layout & Parts

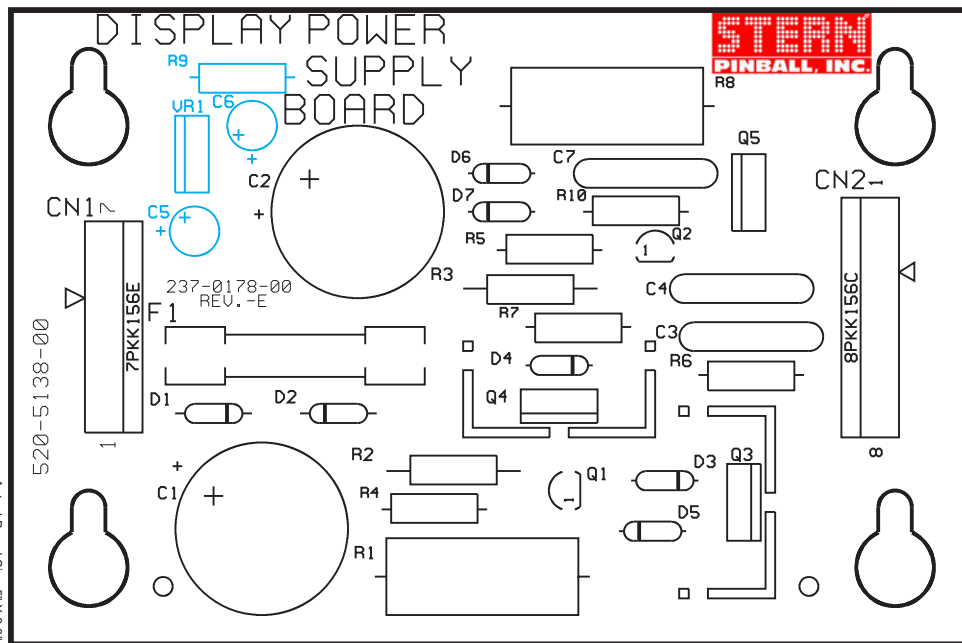

ITEM	QTY	PART NUMBER	REF-DESIGNATOR	DESCRIPTION (NS = Not Stuffed)
—	1	520-5138-00	Display Power Supply Board	Complete PCB Assembly
01	2	125-5044-00	C1, C2	220uF, 200v, Radial Lytic Cap.
02	3	125-5035-00	C3, C4, C7	0.1uF, 500v, Ceramic Disk Cap.
03	0	125-5003-00	(C5, C6: NS)	22uF, 35v, Rad Lytic Cap
04	1	045-5015-07	CN1	7PKK156E (PIN5=KEY)
05	1	045-5015-08	CN2	8PKK156E (PIN3=KEY)
06	2	112-5003-00	D1, D2	1N4004, Diode
07	2	112-0053-00	D3, D4	1N5228, 3.9v, Diode
08	1	112-0062-00	D5	1N4760A, 68v, Diode
09	1	112-0049-00A	D6	1N4764A, 100v, Diode
10	1	112-0061-00	D7	1N4743, 13v, Diode
11	1	200-5000-17	F1	3/4A (0.75A) S.B. Fuse
12	2	205-0004-00	F1	Fuse Clip
13	1	110-0100-00	Q1	MPSA92, Transistor
14	1	110-0082-00	Q2	MPSA42, Transistor
15	2	110-0101-00	Q3, Q5	MJE15030, Transistor
16	2	535-5000-11	Q3, Q4	Heatsinks - AAVID #563002
17	2	240-5008-00	Q3, Q4	#6-32 KEPS Nut
18	2	237-5501-00	Q3, Q4	#6-32 X 3/8" PPH Screw
19	1	110-0103-00	Q4	MJE15031, Transistor
20	1	121-5061-00	R1	130 Ω 5W Res.
21	2	121-5060-00	R2, R3	47K Ω 1W Res.
22	3	121-5038-00	R4, R5, R10	1.5K Ω 1/2W Res. (R9: NS)
23	2	121-5059-00	R6, R7	330K Ω 1/2W Res.
24	1	121-5062-00	R8	2K Ω 5W Res.
25	0	124-5003-00	(VR1: NS)	7812CT



Display Controller Board Schematic

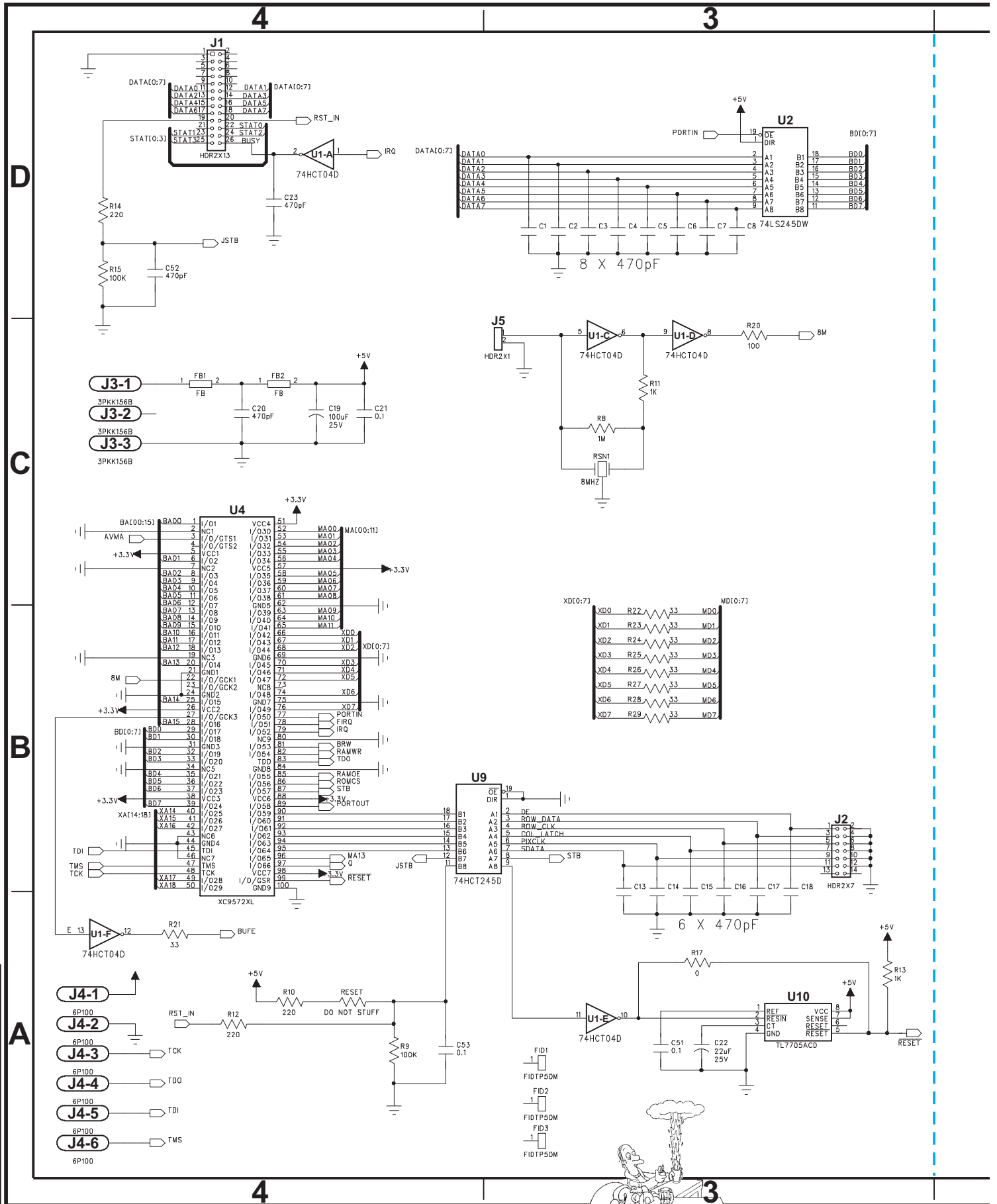

Sec. 5: PCBs



Display Controller Board Schematic

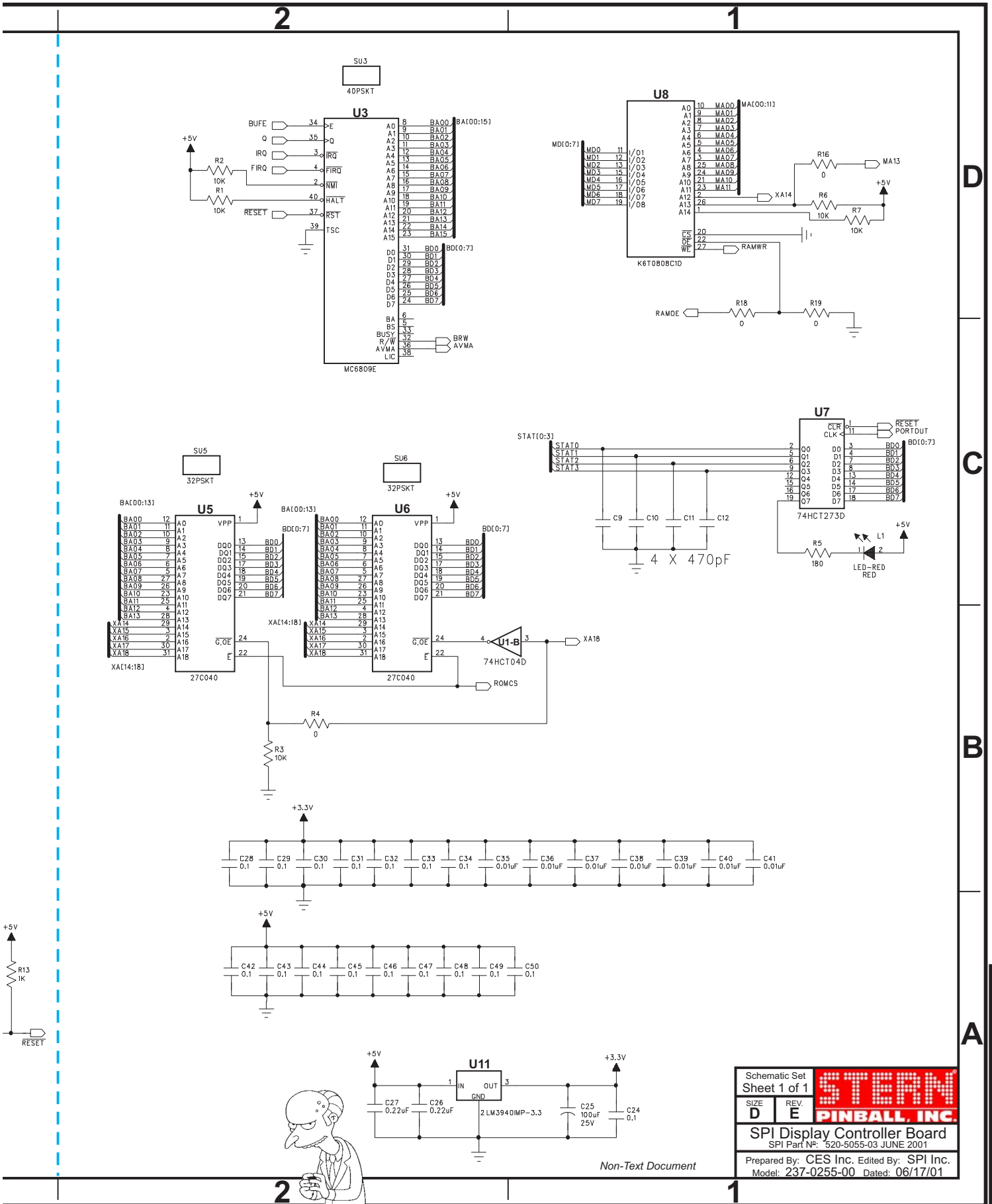

D
C
B
A

Sec. 5: PCBs

Schematic Set
Sheet 1 of 1

STERN
PINBALL, INC.

SPI Display Controller Board
SPI Part No: 520-5055-03 JUNE 2001

Prepared By: CES Inc. Edited By: SPI Inc.
Model: 237-0255-00 Dated: 06/17/01

SIZE	REV.
D	E

Non-Text Document

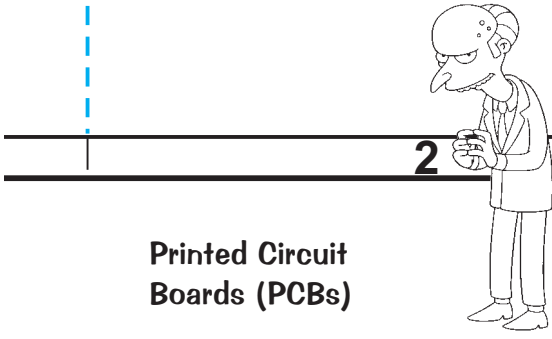

Display Controller Board Component Layout & Parts

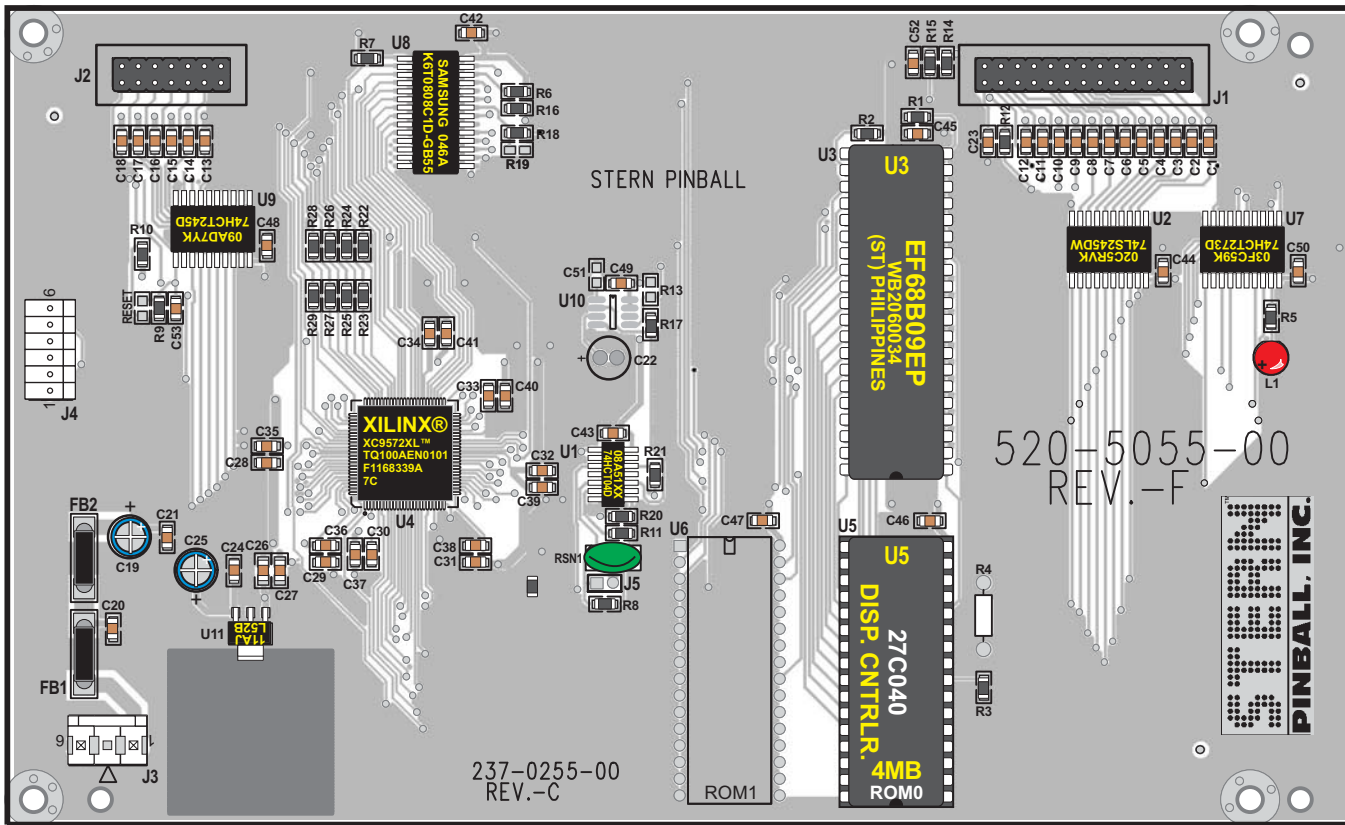

Actual Board Size 20.5cm X 12.5cm

ITEM	QTY	PART NUMBER	REF-DESIGNATOR	DESCRIPTION (NS = Not Stuffed)
—	1	520-5055-03	Display Controller Bd. (FCC FEB98) Rev. E June 2001	Complete PCB Assembly
01	1	045-5015-26	J1	13-Pin, Dual row .1" Hdr. Conn HDR2X13
02	1	045-5015-02	J2	7-Pin, Dual Row .1" Hdr. Conn HDR2X7
03	1	045-5015-03	J3	3-Pin, PKK156B Connector
04	1		J4	6-Pin (6P100)
05	7		C35-C39, C40, C41	SMT 0.01uF, 50v Cap. 103-0805-X7R
06	20		C21, C24, C28-C32, C33, C34, C42, C43, C44, C45, C46 C47, C48, C49, C50, C53 (C51: NS)	SMT 0.1uF, 50v Cap. 104-0805
07	2		C26, C27	SMT 0.22uF, 50v Cap. 224-1206-Z5U
08	21		C1-C12, C13-C18, C20, C23, C52	SMT 470pF, 50v Cap. 471-0805
09	2		C19, C25	100uF, 25v TCap.
10	1	165-5099-00	L1	LED T1-3/4 DIFFUSER RED
11	4		R16-R18 (R19: NS)	0 Ω 1/10W Resistor 0805
12	1	n/a	RESET	DO NOT STUFF
13	2		R11, R13	SMT 1K Ω 1/10W Resistor 0805
14	1		R8	SMT 1M Ω 1/10W Resistor 0805
15	5		R1, R2, R3, R7 (R6: NS)	SMT 10K Ω 1/10W Resistor 0805
16	9		R21, R22-R29	SMT 33 Ω 1/10W Resistor 0805
17	1		R20	SMT 100 Ω 1/10W Resistor 0805
18	2		R9, R15	SMT 100K Ω 1/10W Resistor 0805
19	1		R5	SMT 180 Ω 1/10W Resistor 0805
20	3		R10, R12, R14	SMT 220 Ω 1/10W Resistor 0805
21	1		U1	74HCT04D (74LS04)
22	1		U2	74LS245DW
23	1	100-0189-01	U3 (40-Pin Socket, 077-X)	MC6809E
24	1	100-5044-00	U4	XC9572XL, Int. Xilinx®
25	2 (See Pg. DR. Table)		U5 (ROM0) (U6: NS) (32-Pin, IC Dip Socket, 077-5217-00)	4MB ROM 27C040 (M27C401-100)
26	1		U7	74HCT273D
27	1	100-5045-00	U8	K6T0808C1D-GB55, Int. Samsung 046A
28	1		U9	74HCT245D
29	1		U11	LM3940IMP-3.3
30	1		RSN1	8MHZRSN (8Mhz) Crystal
31	2	n/a	FB1, FB2	Ferrite Bead, FB0370
32	0		FID1-3	FIDTP50M

If a part is required where a part number is not provided, call Technical Support (see back of cover).

Sec. 5: PCBs



I/O Power Driver Board Theory of Operation

5v Supply:

An AC voltage of approximately 9v comes into the board at [J17-(1-4)] this AC voltage is then *full-wave rectified* by bridge **BRDG 21** and filtered by Capacitor **C203**. The resulting voltage is 11v DC which is inserted into a linear voltage regulator for the output of 5v DC. This 5v regulated voltage can be adjusted by potentiometer **R116** the voltage should be set to 5.00v. Besides powering the **I/O Board** the regulated 5 volts supplies power to the **CPU / Sound Board, Gas Plasma (Dot Matrix) Display** and **Plasma (Display) Controller Board**. Power for these devices comes off the **I/O Board** on [J16-(4-8)].

+5v, +20v, +50v, +18v, & +12v LED Indicators:

These DC voltages are derived on the **I/O Board** by rectification and filtering. Each has a **LED** indicating that power is being supplied to each of these voltage sources. The **-12v** supply comes from the same transformer winding as the **+12v** thus it does not have a **LED** indicator.

LED	SUPPLY VOLTAGE
L2	+ 5
L200	+ 20v
L201	+ 50v
L202	+ 18v
L203	+ 12v

**** Note that the +50v & +20v power sources are turned off by the Interlock Switches when the Coin Door is OPEN.**

Reset Circuitry:

The **I/O** will reset in three (3) cases:

1. The CPU is in reset. The CPU's reset signal is fed into the **I/O** through connector **J1** and forces the **I/O** into reset.
2. The 5v supply has fallen below 4.75v.
3. The watchdog is not being fed by the scanning of the light matrix. More specifically **Pin-19** of **U6** must be toggling once every **50ms** to prevent the watchdog from resetting. The scanning of the light matrix is controlled by the CPU through **J1**.

LED L204 shows the reset state of the **I/O Board**. If this **LED** is not lit either the 5v DC is below 4.75v or the **CPU/Sound Board** is holding the **I/O** in reset. If the **LED** is flashing this means that the watchdog is not being feed by the **CPU/Sound Board** and the **I/O** is oscillating into and out of reset. If the **LED** is continuously on the board is out of reset and communication from the CPU to the lamp matrix is confirmed. **Testpoint Blanking** is the actual reset signal on the **I/O Board**. A low voltage indicates that it is in reset this will turn off all Solenoid (*Coil*) Drivers, Flash Lamps, Lamp Matrix Drivers, Auxiliary Outputs and Flipper Outputs. A high voltage indicates that it is out of reset and normal operation can take place.

Address Decoding:

All Address decoding is done by two **74LS138's (U204 & U205)** (3 of 8 decoder). Both of these must be in operation for the **I/O Board** to function properly.

Solenoid (Coil) Drivers & Flash Lamps:

J8 & J9 are high side drivers for driving solenoids and other heavy loads. Each connector has its own buffer driving 8 drivers. **J8 & J9** consist of **MOSFET Drivers 20N10L** which can easily & safely be tested by clipping one end of a clip-lead to test point **FET TPL1** and then the other to the corresponding gate resistor **R1-R16** (see Note 1). This will apply 3.4v to the gate of the **MOSFET Transistor** thus switching it on. **J7 & J6** each are a bank of 8 low side driver for driving lamps or other lower current solenoids (*coils*). They use a Bipolar Power Transistor **TIP122** which can also be tested by using **TEST POINT TIP TPL3** and the corresponding resistors **R17-R32*** (see Note 1).

Note 1 • Clip on the resistor side with the white stripe. •• R1 controls Q1, R2 controls Q2, et cetera...

Auxiliary In & Out:

J2-8 CMOS Outputs sometimes used for a printer interface.

J3-8 CMOS Inputs general purpose inputs.

Lamp Matrix:

J12 has 10 low side drivers for the lamp strobes which consist of **19N06L MOSFETS**. Only one lamp strobe should be low at any time. Again the scanning of the lamp strobes keeps the **I/O** from resetting. **J13** has 8 high side drivers with each having a status indicator. All the status indicators are logically 'OR'ed together and fed back to the **CPU/Sound Board**. The status can identify open loads (for example open lamp filaments or intermittent connections) and short circuits. These drivers are also short-circuit protected.

General Illumination (G.I.) Lights:

J15 has 6v AC switched on & off by a relay on the **I/O Board**. The relay is controlled by **Q200** which supplies power to the 24v coil winding to activate the relay. There are 4 taps on **J15** each fused at 5A for this 6v AC source.



I/O Power Driver Board Schematic (Sheet 1 of 5)

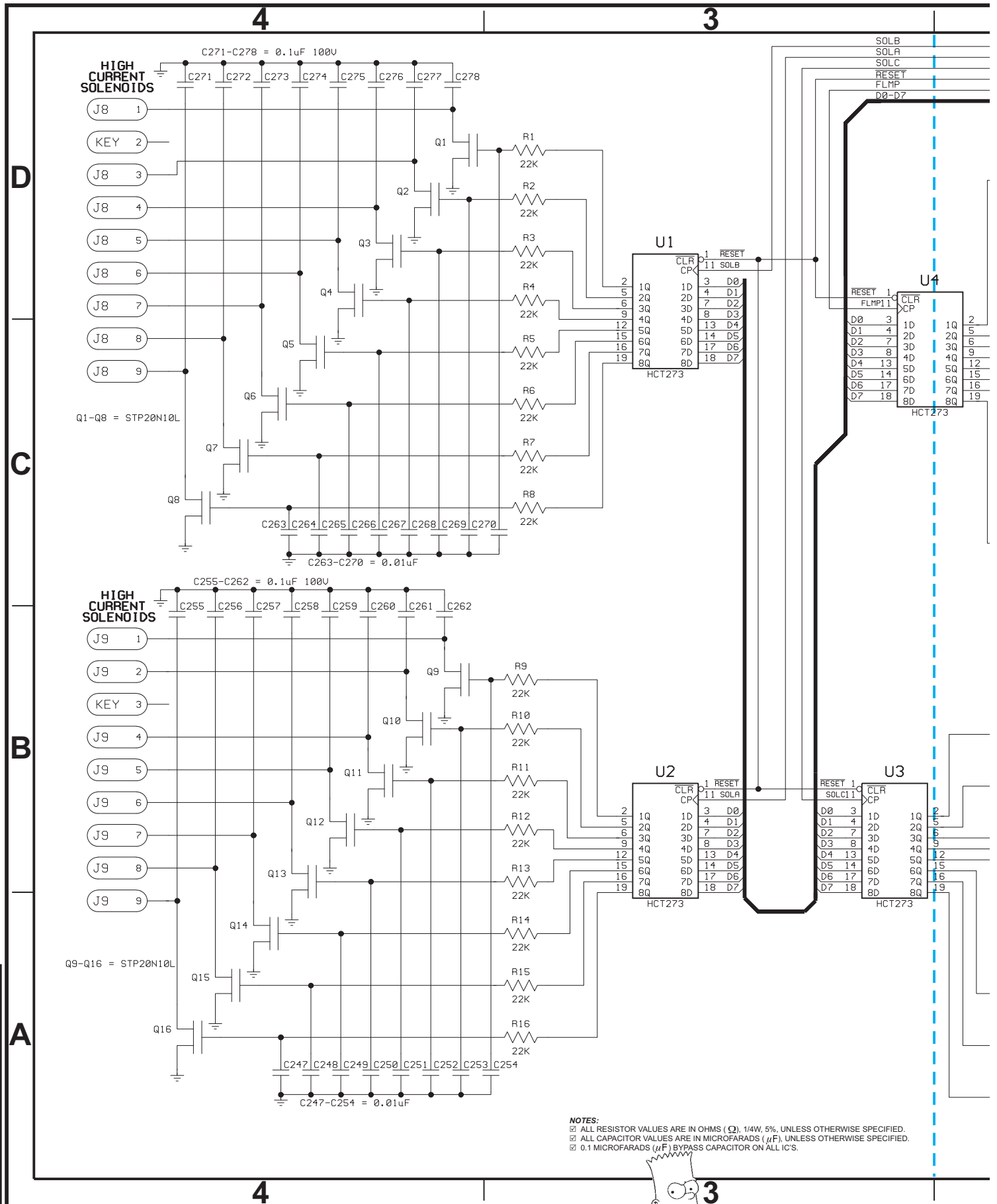

- NOTES:**
- ☑ ALL RESISTOR VALUES ARE IN OHMS (Ω), 1/4W, 5%, UNLESS OTHERWISE SPECIFIED.
 - ☑ ALL CAPACITOR VALUES ARE IN MICROFARADS (μ F), UNLESS OTHERWISE SPECIFIED.
 - ☑ 0.1 MICROFARADS (μ F) BYPASS CAPACITOR ON ALL IC'S.

Sec. 5: PCBs



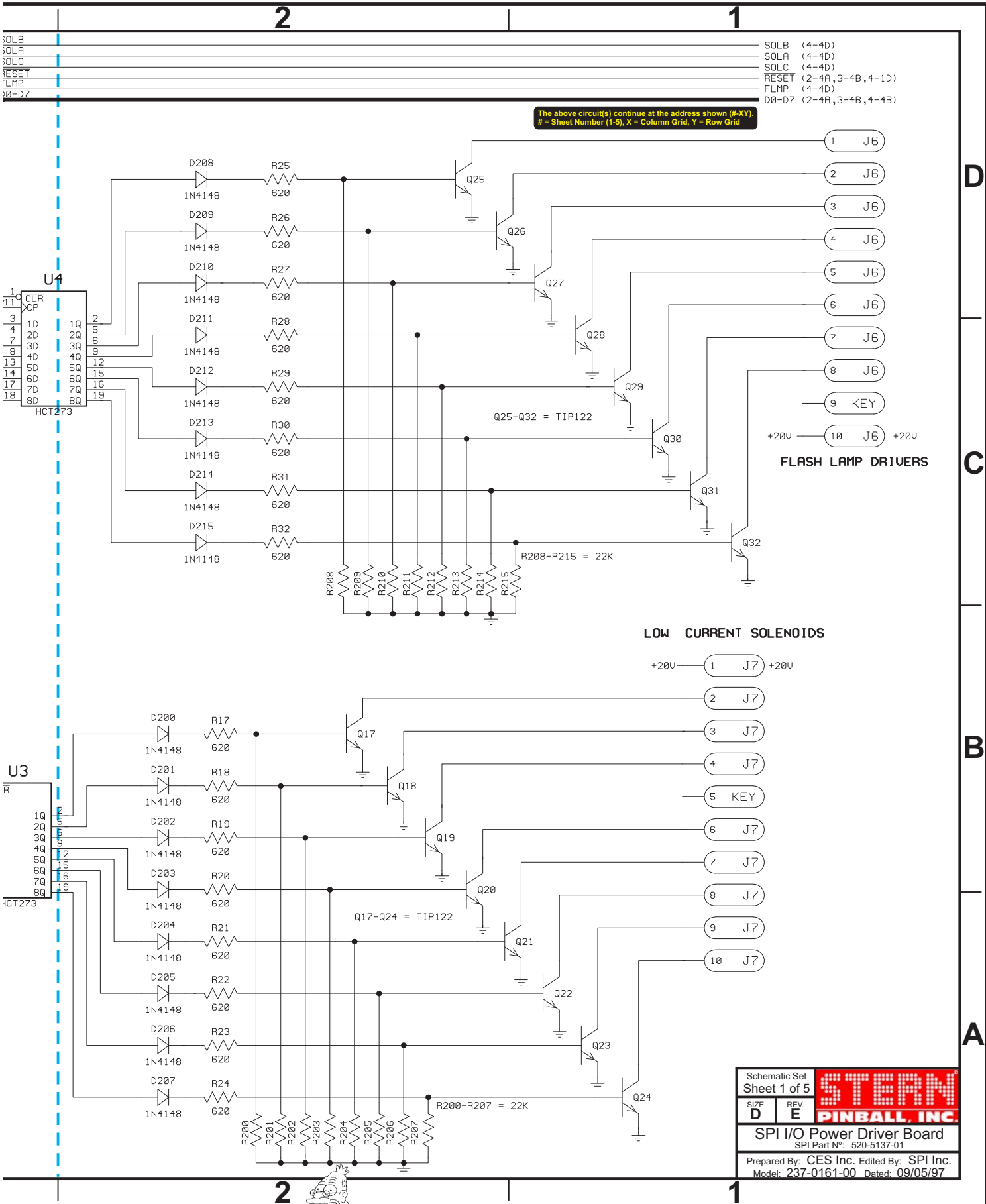

D
C
B
A

Sec. 5: PCBs

Schematic Set		STERN
Sheet 1 of 5		
SIZE	REV.	PINBALL, INC.
D	E	
SPI I/O Power Driver Board		
SPI Part No: 520-5137-01		
Prepared By: CES Inc. Edited By: SPI Inc.		
Model: 237-0161-00 Dated: 09/05/97		

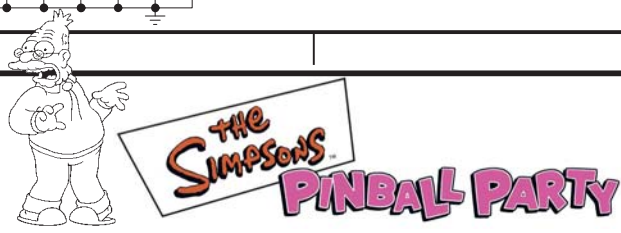

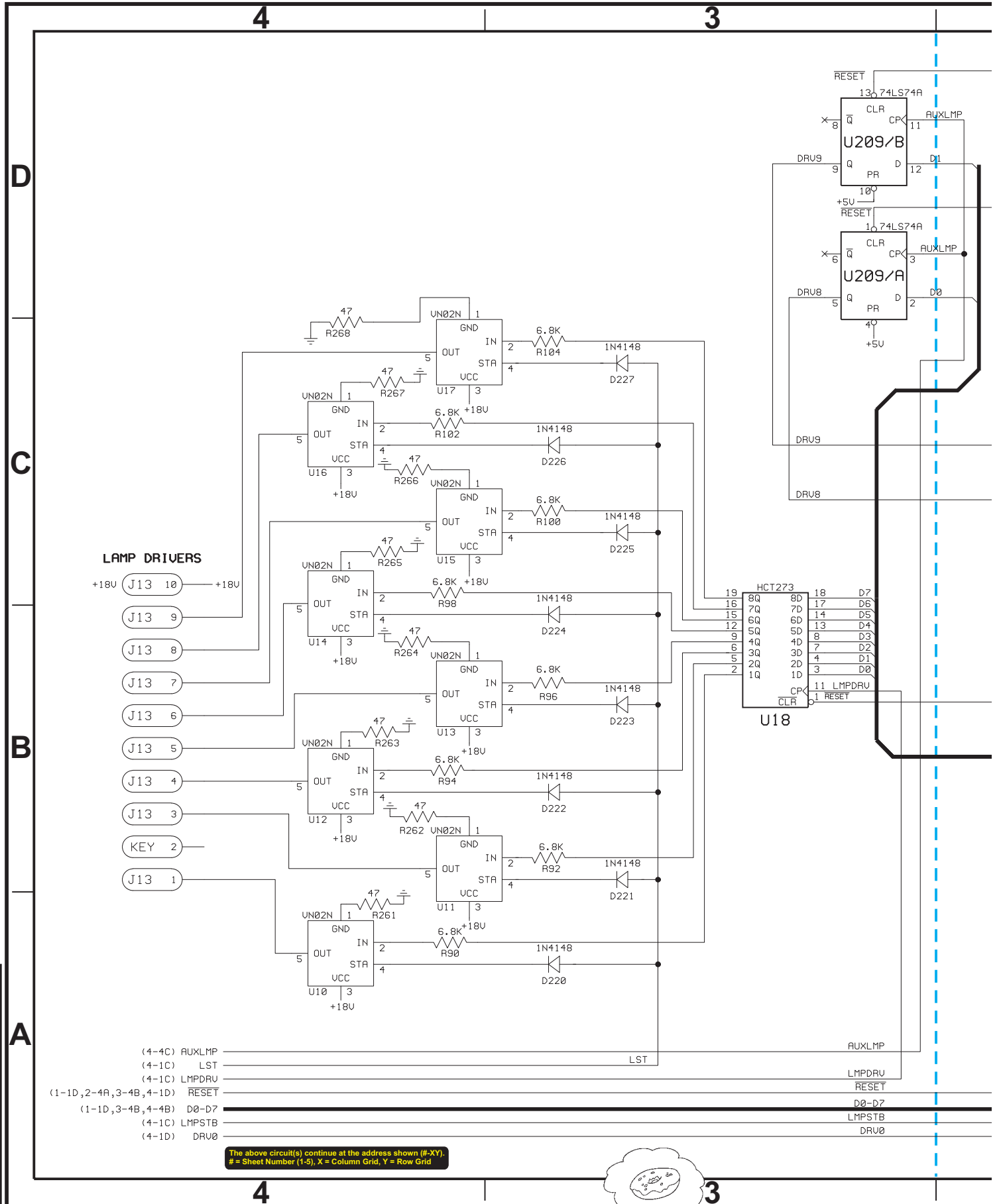

- (4-4C) AUXLMP
- (4-1C) LST
- (4-1C) LMPDRV
- (1-1D, 2-4A, 3-4B, 4-1D) RESET
- (1-1D, 3-4B, 4-4B) D0-D7
- (4-1C) LMPSTB
- (4-1D) DRV0

The above circuit(s) continue at the address shown (#.XY).
 # = Sheet Number (1-5), X = Column Grid, Y = Row Grid

Sec. 5: PCBs



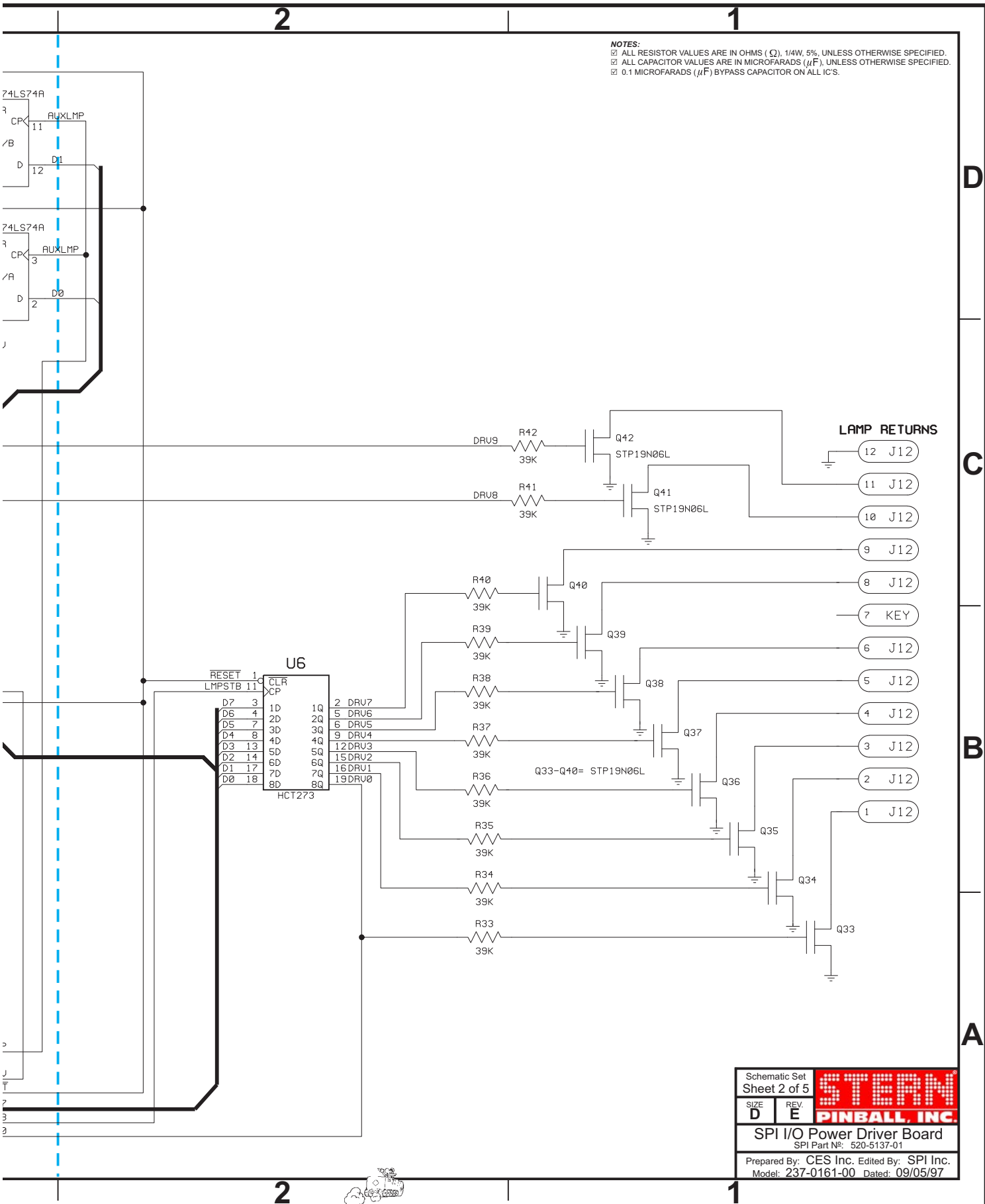

Schematic Set		STERN	
Sheet 2 of 5			
SIZE	REV.	PINBALL, INC.	
D	E		
SPI I/O Power Driver Board			
SPI Part No: 520-5137-01			
Prepared By: CES Inc. Edited By: SPI Inc.			
Model: 237-0161-00 Dated: 09/05/97			

Sec. 5: PCBs

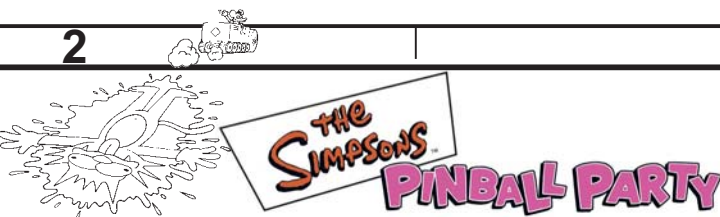

I/O Power Driver Board Schematic (Sheet 3 of 5)

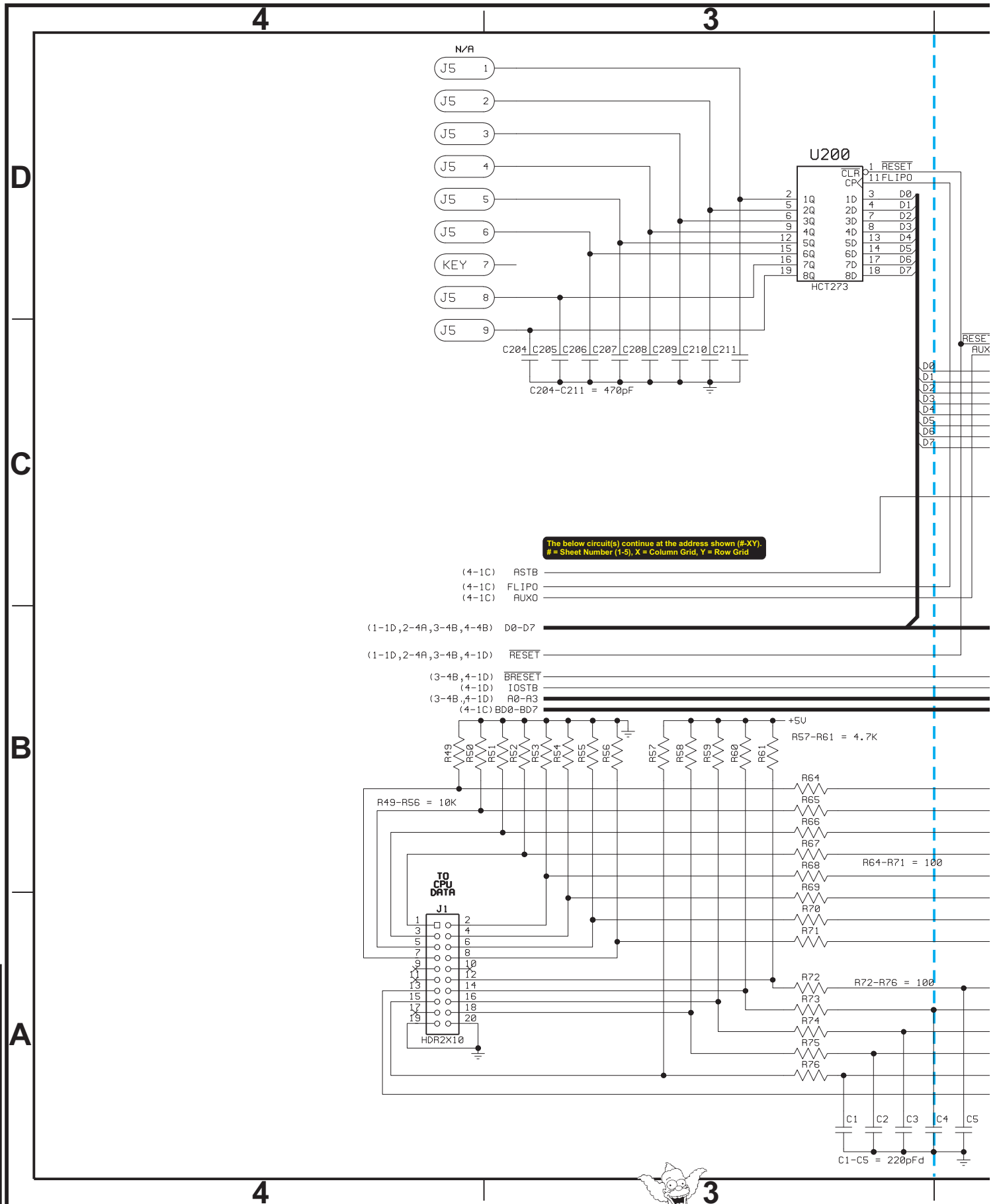

The below circuit(s) continue at the address shown (#-XY).
 # = Sheet Number (1-5), X = Column Grid, Y = Row Grid

- (4-1C) ASTB
- (4-1C) FLIPO
- (4-1C) AUXD
- (1-1D, 2-4A, 3-4B, 4-4B) D0-D7
- (1-1D, 2-4A, 3-4B, 4-1D) RESET
- (3-4B, 4-1D) BRESET
- (4-1D) IOSTB
- (3-4B, 4-1D) A0-A3
- (4-1C) BD0-BD7

Sec. 5: PCBs



2

1

NOTES:
 ☑ ALL RESISTOR VALUES ARE IN OHMS (Ω), 1/4W, 5%, UNLESS OTHERWISE SPECIFIED.
 ☑ ALL CAPACITOR VALUES ARE IN MICROFARADS (μF), UNLESS OTHERWISE SPECIFIED.
 ☑ 0.1 MICROFARADS (μF) BYPASS CAPACITOR ON ALL IC'S.

DATE	DESCRIPTION OF CHANGES / REVISIONS	REQ.	BY.
JAN 2001	Cut trace on solder side at Aux. Out Port J2-PIN1 thru J2-PIN3 & J2-PIN5 thru J2-PIN9; Soldered Resistor 100Ω 1/4W 5% (SPI N#: 121-5007-00). This Modification (highlighted below at J2 with a dotted-line box) was accomplished on boards produced after Jan. 1, 2001. This board is backwards compatible for the White Star™ Board System.	TS	JET

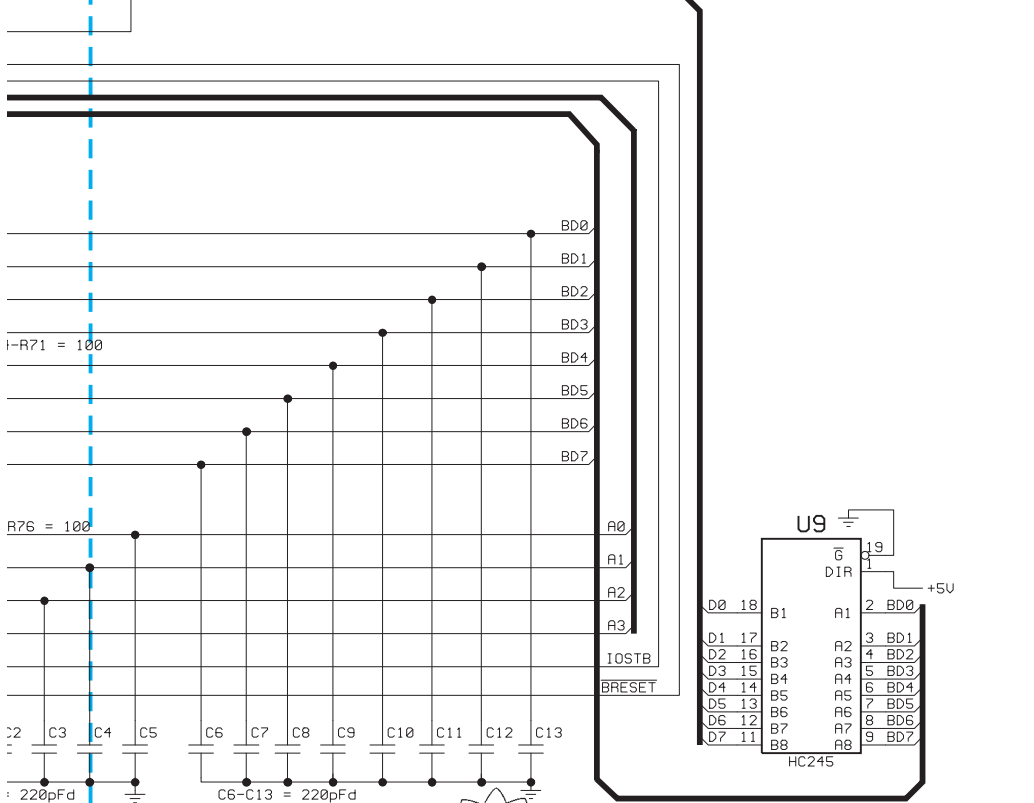
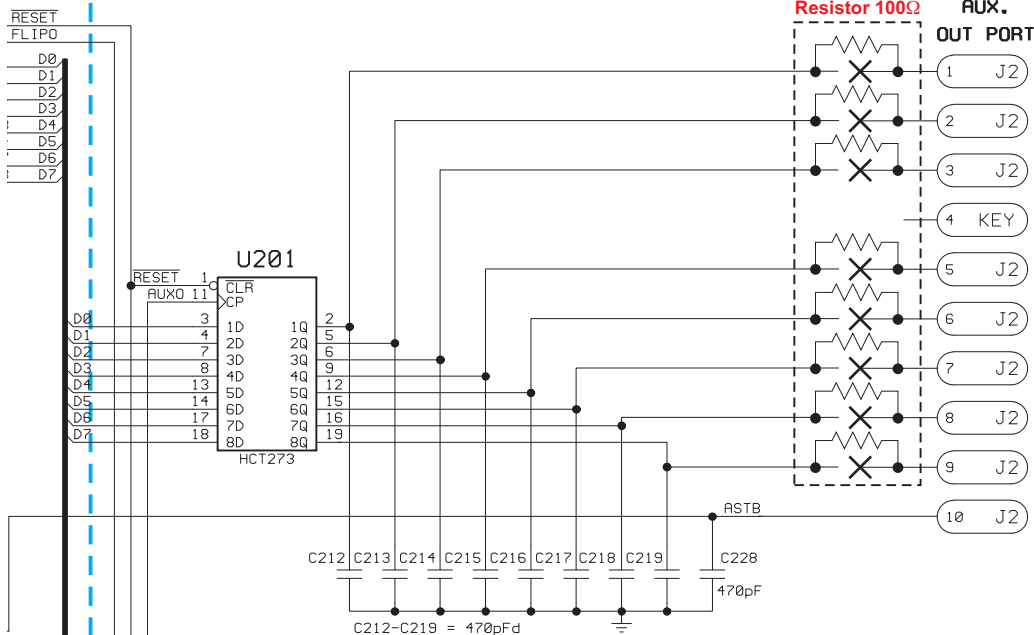

D
C
B
A

2

1

Schematic Set Sheet 3 of 5		STERN PINBALL, INC.
SIZE D	REV. E	
SPI I/O Power Driver Board SPI Part N#: 520-5137-01		
Prepared By: CES Inc. Edited By: SPI Inc. Model: 237-0161-00 Dated: 09/05/97		



Sec. 5: PCBs

I/O Power Driver Board Schematic (Sheet 4 of 5)

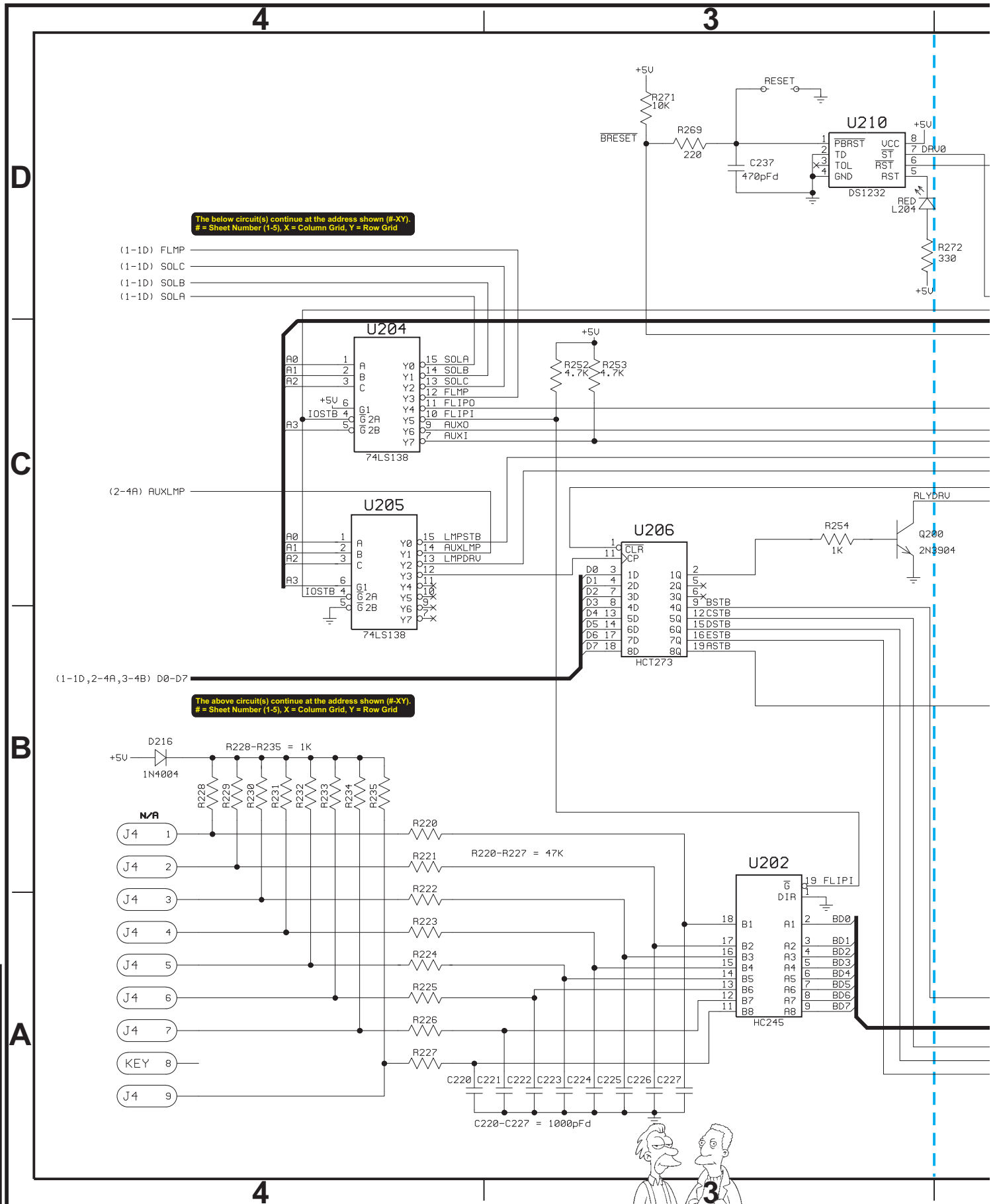

The below circuit(s) continue at the address shown (#-XY).
= Sheet Number (1-5), X = Column Grid, Y = Row Grid

The above circuit(s) continue at the address shown (#-XY).
= Sheet Number (1-5), X = Column Grid, Y = Row Grid

Sec. 5: PCBs



I/O Power Driver Board Schematic (Sheet 4 of 5)

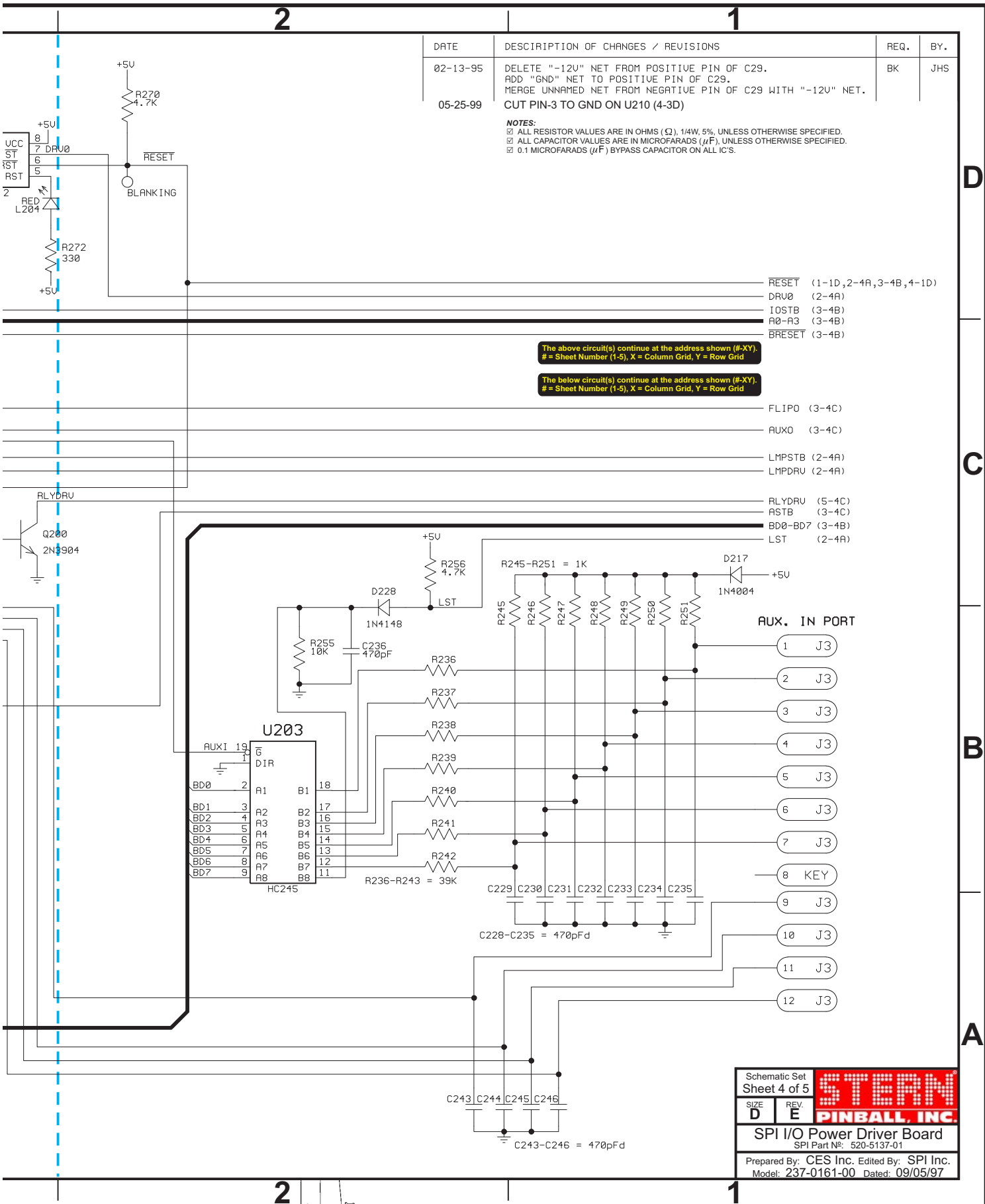

D
C
B
A

Sec. 5: PCBs

Schematic Set Sheet 4 of 5		STERN PINBALL, INC.
SIZE D	REV. E	
SPI I/O Power Driver Board SPI Part No: 520-5137-01		
Prepared By: CES Inc. Edited By: SPI Inc. Model: 237-0161-00 Dated: 09/05/97		



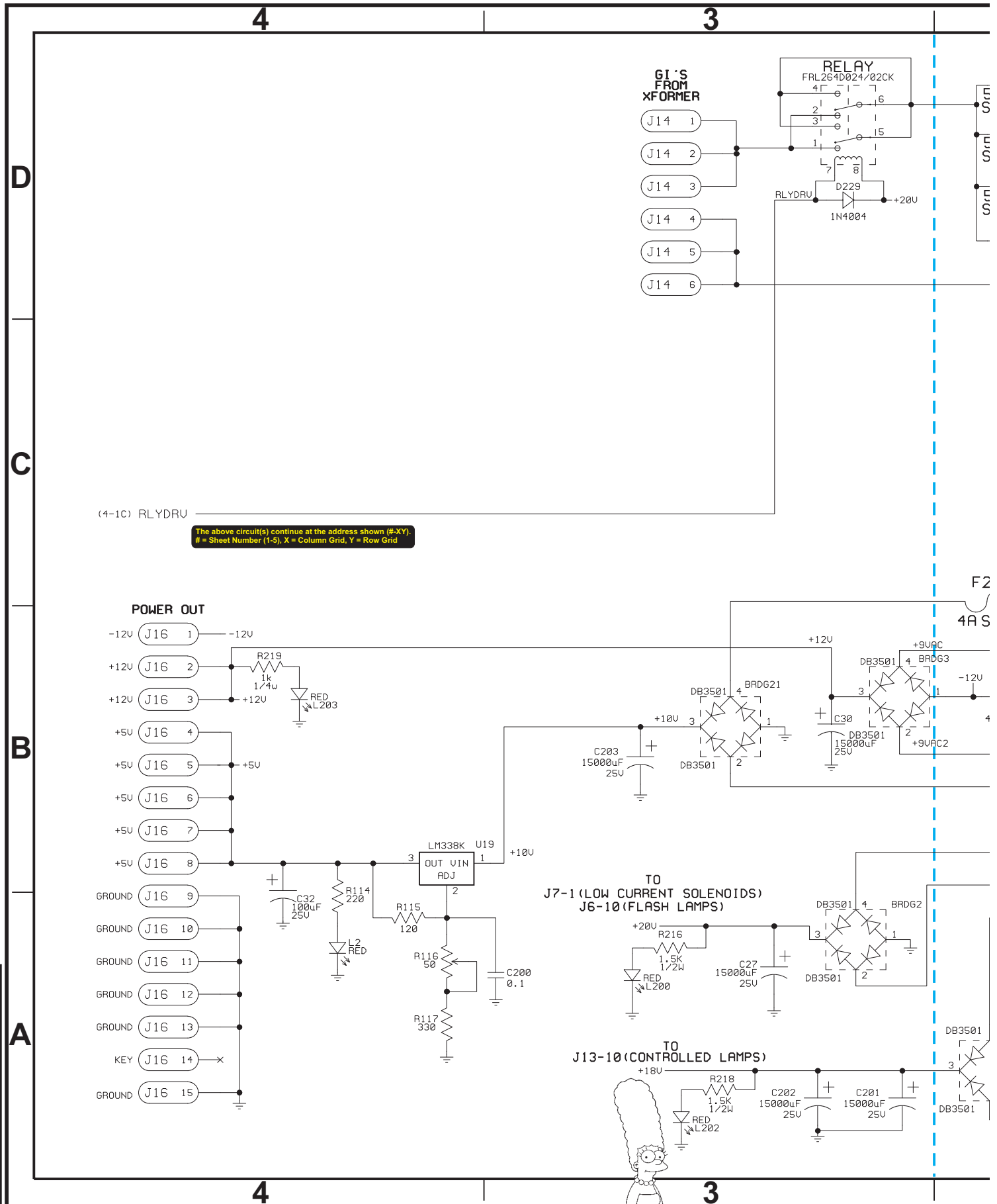

The above circuit(s) continue at the address shown (#-XY).
 # = Sheet Number (1-5), X = Column Grid, Y = Row Grid

Sec. 5: PCBs



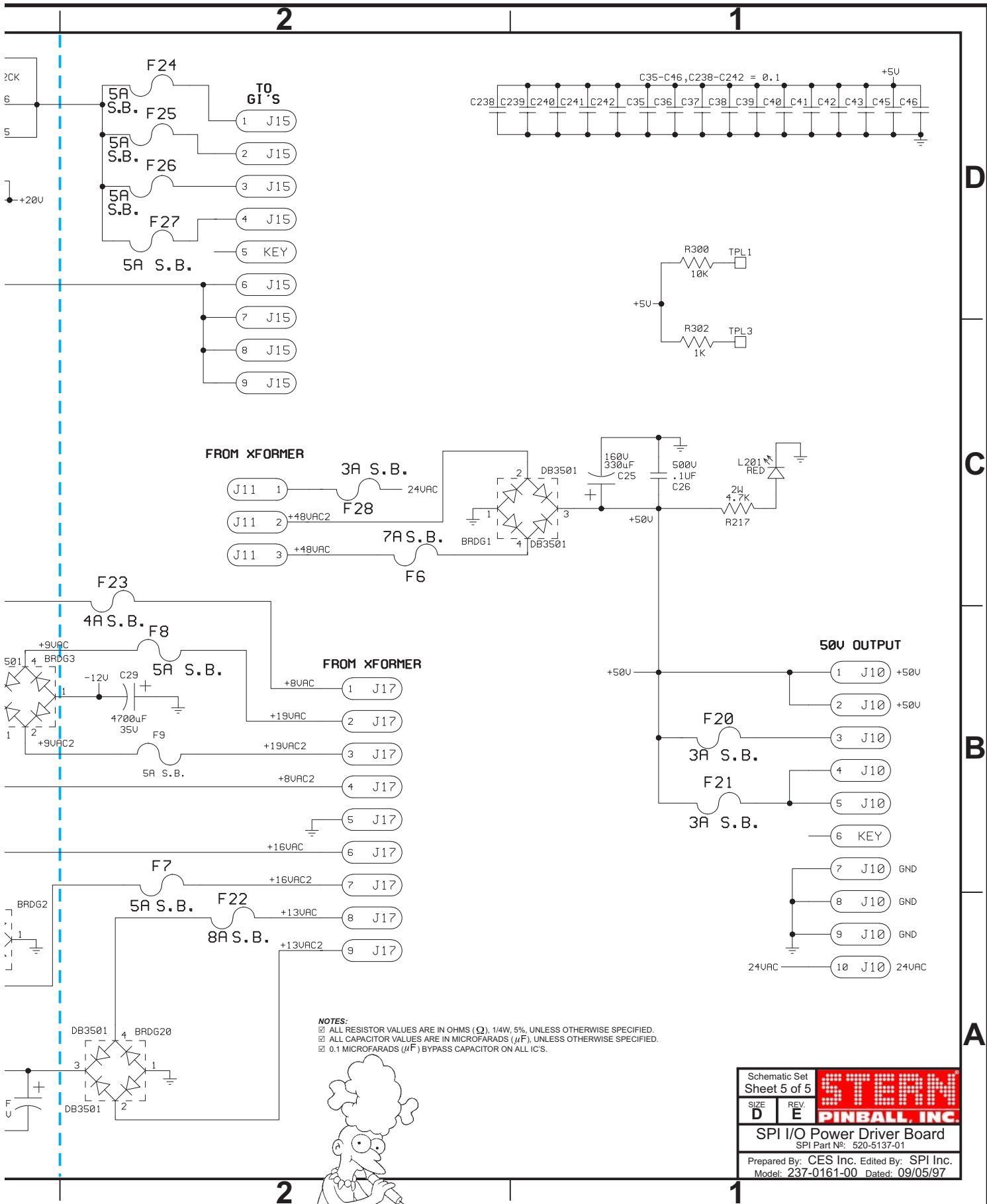

Sec. 5: PCBs

Schematic Set Sheet 5 of 5		STERN PINBALL, INC.
SIZE D	REV. E	
SPI I/O Power Driver Board SPI Part No: 520-5137-01		
Prepared By: CES Inc. Edited By: SPI Inc. Model: 237-0161-00 Dated: 09/05/97		



I/O Power Driver Board Component Layout

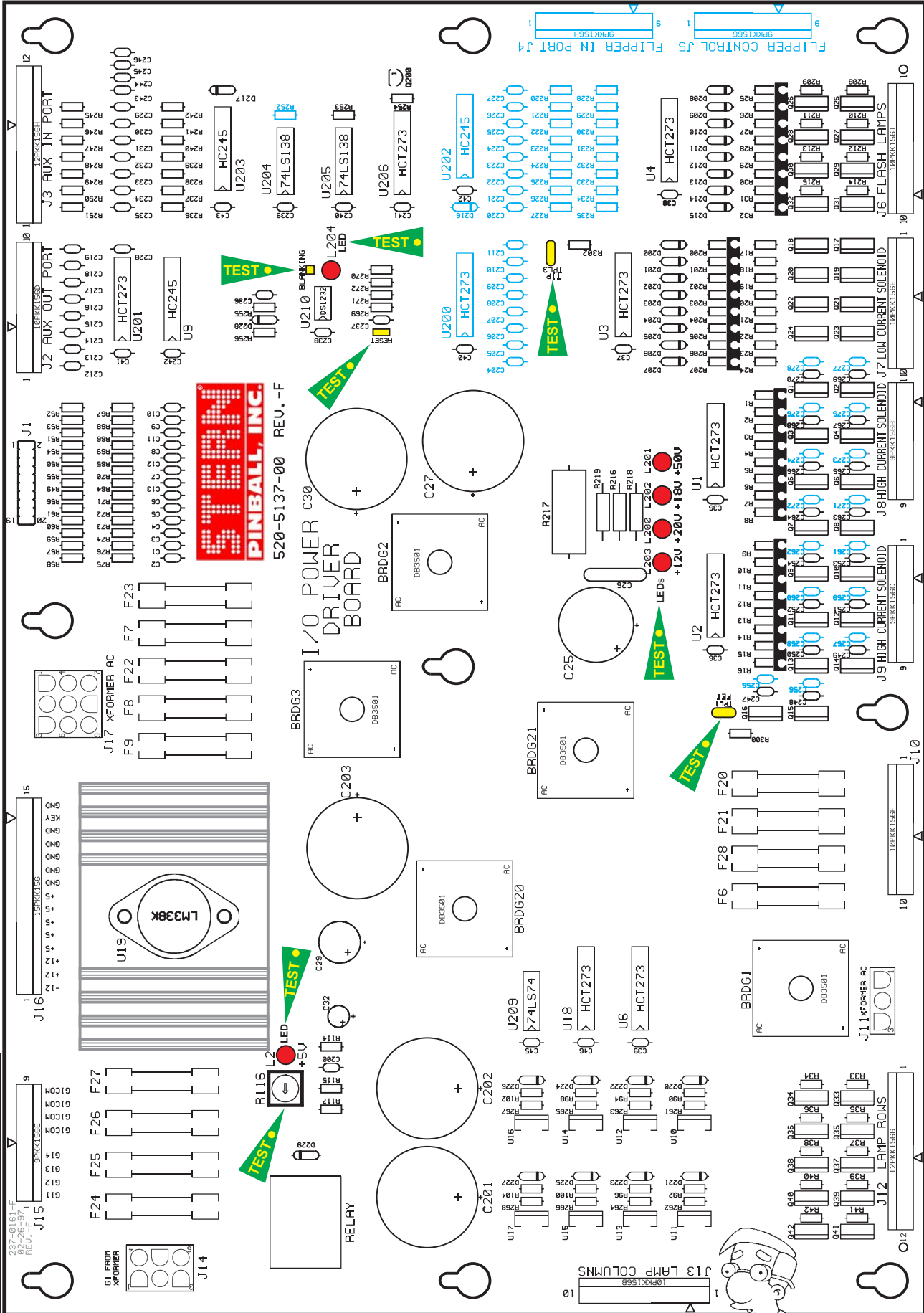

Test Points:



← TIP TPL3
← BLANKING
← L204 LED

← RESET

LEDs :
← L201+50v
← L202+18v
← L200+20v
← L203+12v

← FET TPL1

LED :
← L2+5V
← R116 POT

Actual Board Size 15.698" X 11"



I/O Power Driver Board Parts

ITEM	QTY	PART NUMBER	REF-DESIGNATOR	DESCRIPTION (NS = Not Stuffed)
—	1	520-5137-01	I/O Power Driver Board	Complete PCB Assembly
01	5	112-5000-00	BRDG1, BRDG2, BRDG3, BRDG20, BRDG21	DB3501
02	13	125-5030-00	C1, C2, C3>C6, C7, C8, C9>C10, C11, C12	220pF, (221), Cap.
03	1	125-5033-00	C25	100uF, 150v, Radial Lytic Cap.
04	1	125-5035-00	C26	.1uF, 500v, Ceramic Disk Cap.
05	5	125-5036-00	C27, C30, C201, C202, C203	15000uF, 25v, Radial Lytic Cap.
06	1	125-5034-00	C29	4700uF, 35v, Radial Lytic Cap.
07	1	125-5032-00	C32	100uF, 25v, Radial Lytic Cap.
08	17	125-5031-00	C35, C36, C37, C38, C39, C40, C41, C42, C43, C45, C46, C200, C238, C239, C240, C241, C242	0.1uF, (104), Cap.
09	22	125-5028-00	C212>C219, C228>C237, C243>C246 (C204-C211: NS)	470pF, (471), Axial Cap.
10	0	n/a	(C220>C227: NS)	
11	16	125-5029-00	C247>C254, C263>C270	0.01uF, (103), 100v Cap.
12	0	125-5027-00	(C255>C262, C271>C278: NS)	0.1uF, (104), 100v, Cap.
13	25	112-0054-00	D200>D207, D208>D215, D220, D221, D222, D223, D224, D225, D226, D227	1N4148, Diode
14	2	112-5003-00	D217, D229 (D216: NS)	1N4004, Diode
15	26	205-0004-00	F6, F7, F8, F9, F20, F21, F22, F23, F24> F27, F28	Fuse Clips
16	1	200-5000-03	F6	7A 250v S.B. Fuse
17	7	200-5000-01	F7, F8, F9, F24>F27	5A 250v S.B. Fuse
18	3	200-5000-08	F21, F20, F28	3A 250v S.B. Fuse
19	1	200-5000-05	F22	8A 250v S.B. Fuse
20	1	200-5000-06	F23	4A 250v S.B. Fuse
21	1	045-5015-01	J1	20-Pin, 0.1 Dual Row Header
22	1	045-5014-01	J2 (Key Pin-4), J6 (Key Pin-9), J7 (Key Pin-5) J10 (Key Pin-6), J13 (Key Pin-2)	10PKK156
23	1	045-5015-00	J3 (Key Pin-8)	12PKK156
	0	n/a	(J4, J5: NS)	
24	1	045-5013-00	J8 (Key Pin-2), J9 (Key Pin-3), J15 (Key Pin-5)	9PKK156
25	1	045-0014-03	J11	10-84-4030 (3-Pin MOLEX)
26	1	045-5015-00	J12 (Key Pin-7)	12PKK156
27	1	045-0014-06	J14	10-84-4060 (6-Pin MOLEX)
28	1	045-5016-00	J16 (Key Pin-14)	15PKK156
29	1	045-0014-09	J17	10-84-4090 (9-Pin MOLEX)
30	6	165-5099-00	L2, L200, L201, L202, L203, L204	LED T1-3/4 DIFFUSER LED
31	16	110-0106-00	Q1>Q16	22NE10L STP, Transistor
32	16	110-0067-00	Q17>Q24, Q25>Q32	TIP122
33	10	110-0088-00	Q33>Q42	19N06L STP, Transistor
34	1	110-0069-00	Q200	2N3904, Transistor.
35	32	121-5042-00	R1>R8, R9>R16, R200>R207, R208>R215	22K Ω 1/4W Res.
36	16	121-5003-00	R17>R24, R25>R32	620 Ω 1/4W Res.
37	17	121-5045-00	R33>R42, R236>R242	39K Ω 1/4W Res.
38	8	121-5021-00	R49, R57>R61, R253, R256, R270 (R252: NS)	4.7K Ω 1/4W Res.
39	11	121-5011-00	R50>R56, R255, R271, R300	10K Ω 1/4W Res.
40	13	121-5007-00	R64>R76	100 Ω 1/4W Res.
				Resistors on Solder Side @ J2-Pins: 1-3 & 5-9
41	8	121-5029-00	R90, R92, R94, R96, R98, R100, R102, R104	6.8K Ω 1/4W Res.
42	2	121-5033-00	R114, R269	220 Ω 1/4W Res.
43	1	121-5030-00	R115	120 Ω 1/4W Res.
44	1	121-5039-00	R116	50 Ω Pot
45	2	121-5036-00	R117, R272	330 Ω 1/4W Res.
46	2	121-5038-00	R216, R218	1.5K Ω 1/2W Res.
47	1	121-5050-00	R217	4.7K Ω 2W Res. (SANDBAR)
48	1	121-5009-00	R219, R245>R251, R254, R302 (R228>R235: NS)	1K Ω 1/4W Res.
49	8	121-5016-00	R261, R262, R263, R264, R265, R266, R267, R268	47 Ω 1/4W Res.
50	1	190-5002-00	RELAY	FRL264D024/02CK Relay
51	2	n/a	TPL1, TPL3	Test Point Wire (24ga.) Loops
52	8	100-5012-00	U1, U2, U3, U4, U6, U18, U201, U206 (U200: NS)	74HCT273
53	1	110-0058-00	U9	74LS245
54	1	100-5023-00	U210	DS1232
55	8	110-0089-00	U10, U11, U12, U13, U14, U15, U16, U17	VN02N
56	1	100-0356-00	U19	LM338K
57	1	n/a	U19	Heatsink (5v Reg.)
58	1	100-0338-00	U203 (U202: NS)	74HC245
59	2	100-0148-00	U204, U205	74LS138
60	1	100-0037-00	U209	74LS74
61	1	n/a	BLANKING, RESET	Test Points

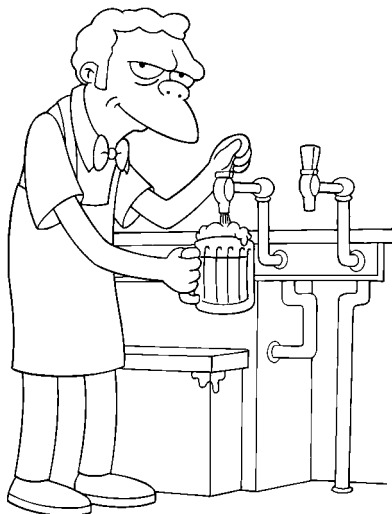

Printed Circuit Boards (PCBs)



Section 5, Chapter 4
Page 129

Sec. 5: PCBs

Your Notes

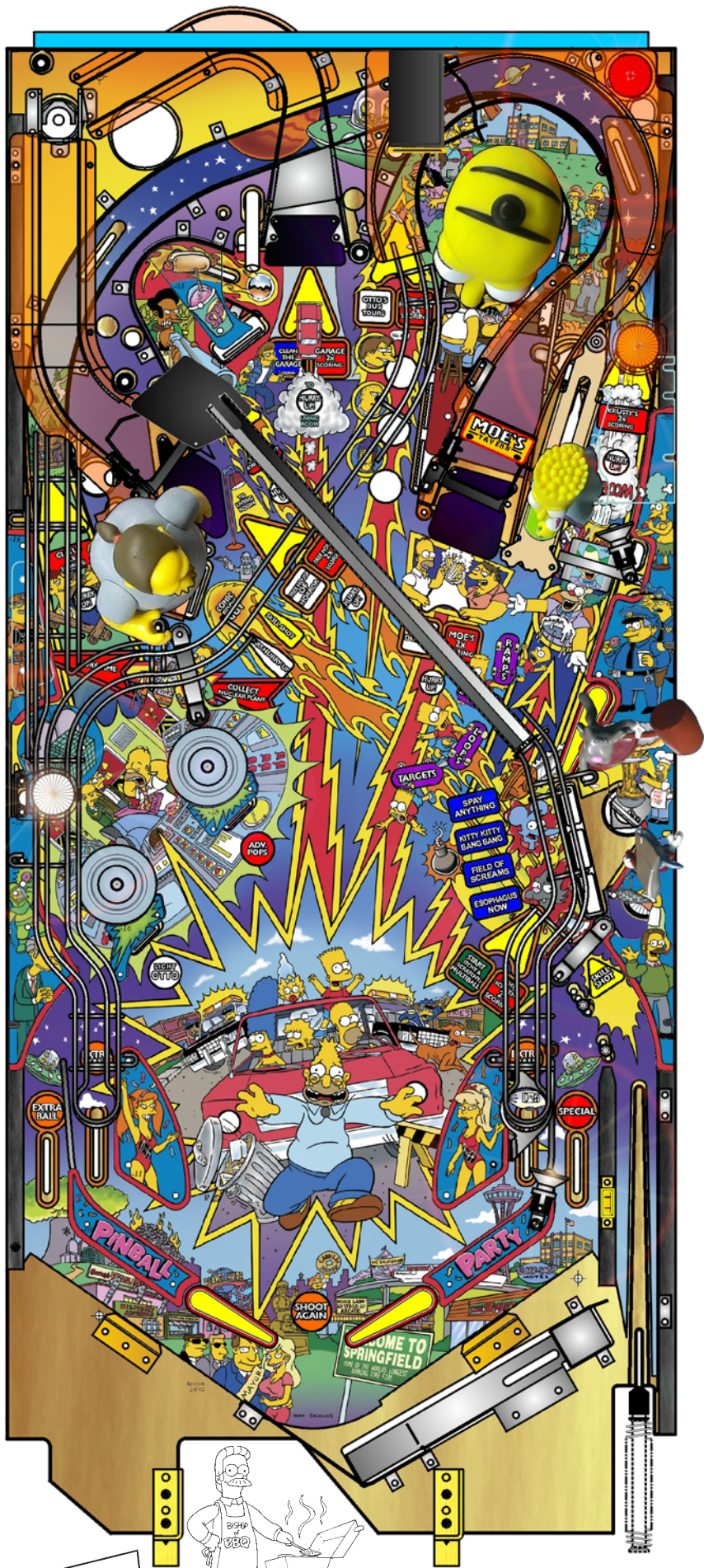
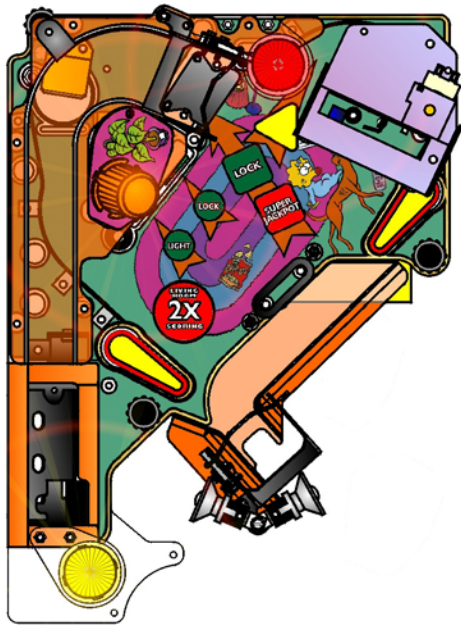
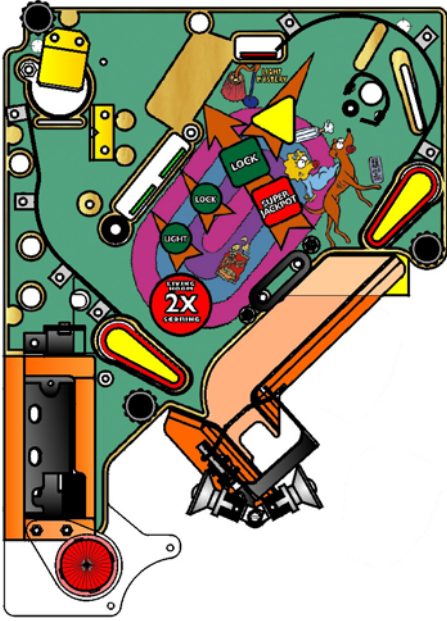

Sec. 5: PCBs



**CPU Section:**

The **CPU** is a **68B09E (U209)** with up to 8 MBytes of **CPU Code Space (U210)**. The **CPU** code is bank selected by the use of **U211** and each bank consists of 16 KBytes. 8 KBytes of **RAM (U212)** is available to the **CPU**. The RAM is battery backed and has a write protected area. Battery back up is accomplished by **3-AA Cells (BAT1)** Battery Pack which has a **TEST POINT (TP): VBATT** to check the battery voltage status. The write protected area consists of 512 Bytes used for storing game settings. This section of **RAM** can only be written to when the coin door is open. The Coin Door switch comes into the **CPU** on **CN6-12** and is fed into the address decoding **PAL U213**. When this memory protect signal is low writes to the protected **RAM** area are prohibited. Address decoding for the system is accomplished by one **PAL U213** and one 1-of-8 decoder **U214**.

A watchdog is used to monitor the **CPU** and the 5v supply. If the 5v supply is below 4.75 the watchdog will hold the **CPU/Sound Board & I/O Board** in *reset*. The watchdog must be fed at a rate of **250ms** or faster. The signal used to feed the watchdog comes from the EPROM Bank select signal used to load **U211**.

The **I/O** Interface **CN1** is buffered by two (2) **HC245** Chips (**U207 & U208**). The **CPU's** reset line is buffered by **Q10** and fed over to the **I/O** through **CN1**. An *I/O Strobe Signal* is fed through **CN1-15** and is used to notify the **I/O** that a valid address is being sent.

Switches:

The Switch Matrix consists of eight (8) **2N3904** Transistors(**Q1-Q8**) which pull one of 8 strobes 'low' to *activate* a Single Column of switches. The *Switch Return Signals* are fed into **CN7** [SWITCH ROWS] and are highly filtered and compared to a 2.5v *reference voltage*. The *Switch Return Voltage* must be below 2.5v to make a *Valid Switch Closure*. If *false switches* are appearing, check that none of the **2N3904** Transistors are permanently pulling the *strobe line low*. Only one strobe from **CN5** [SWITCH COLUMNS] should be *low at any time*. **CN6** [DEDICATED SWITCH IN] is a *Dedicated Bank of Input Switches*. Switches connected to **CN6** are connected to ground instead of a strobe and may be read at any time.

Plasma Interface:

The data path for communication to and from the **Plasma Controller Board** is 8 bits wide. There are separate *Input* and *Output Busses*. Data going out to the controller comes from the **CPU's Data Bus** through **U201** and onto **CN8-Pins 11-18**. Status back from the Plasma Controller comes in on **CN8-Pins 22-26** and is fed into **U202** for input to the **CPU's Data Bus**. Two control signals that go out to the Plasma Controller are **PRES** [TP17: PLASMA RESET] and **CN8-Pin 19 [PSTB - Plasma Strobe]**. The Plasma Reset is software controllable through **U216/B** and also has a test point "Plasma Reset". The *Plasma Strobe Signal* to the controller is generated from **U216/A** and is *used to latch data* into the Plasma Controller.

Other Test Points (TP):

TP 7: E & TP5: Q - The **CPU** signals for both **68B09E** processors. Should be at 2Mhz with **Q** leading **E** by **500 nsec**. **TP2: P0. TP3: P1. TP4: P2. TP20: (near U402). TP8: (near U219). TP1: +3.3V.**

CPU/Sound Board II (with ATMEL Processor) Schematic (Sheet 1 of 4)

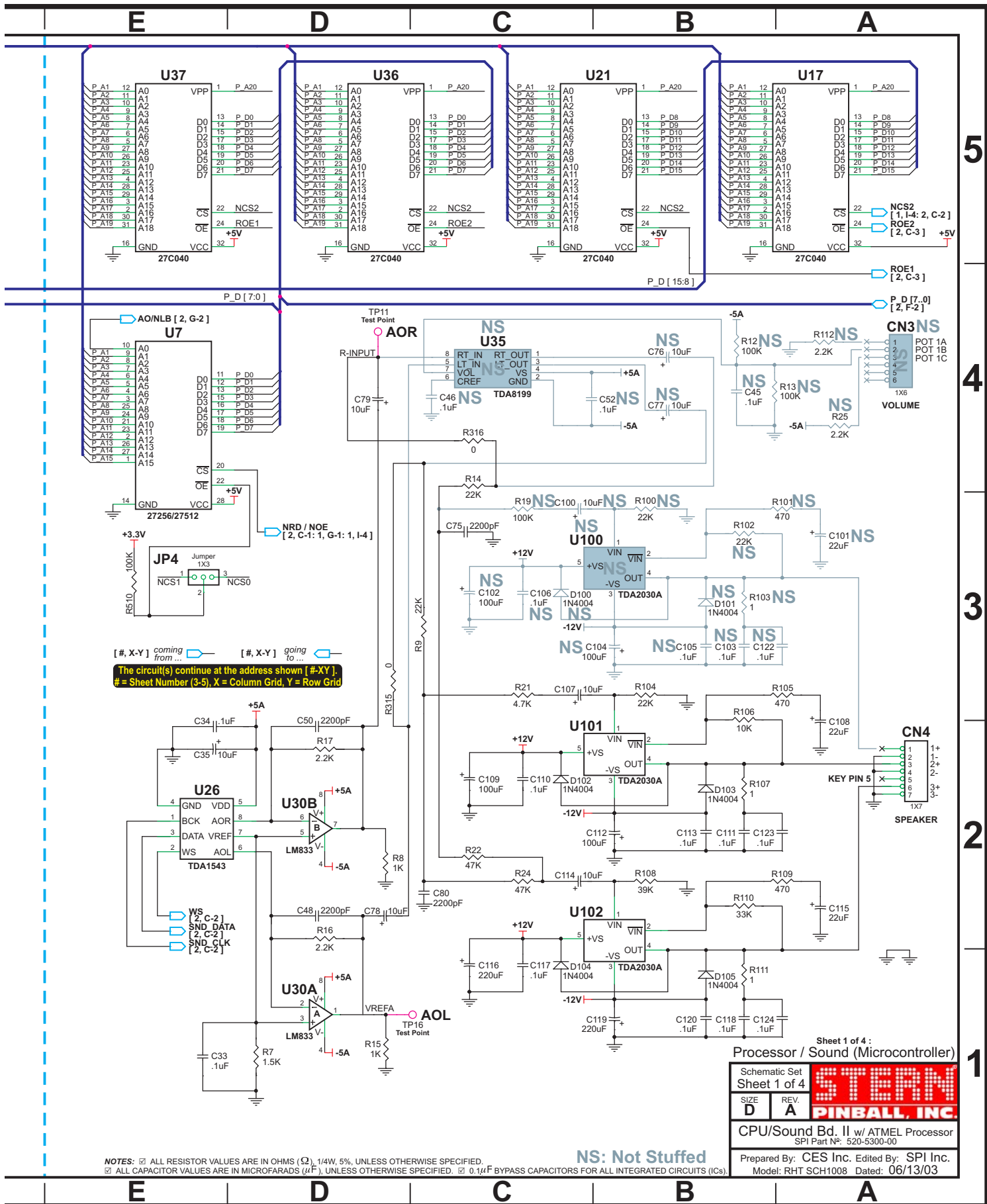

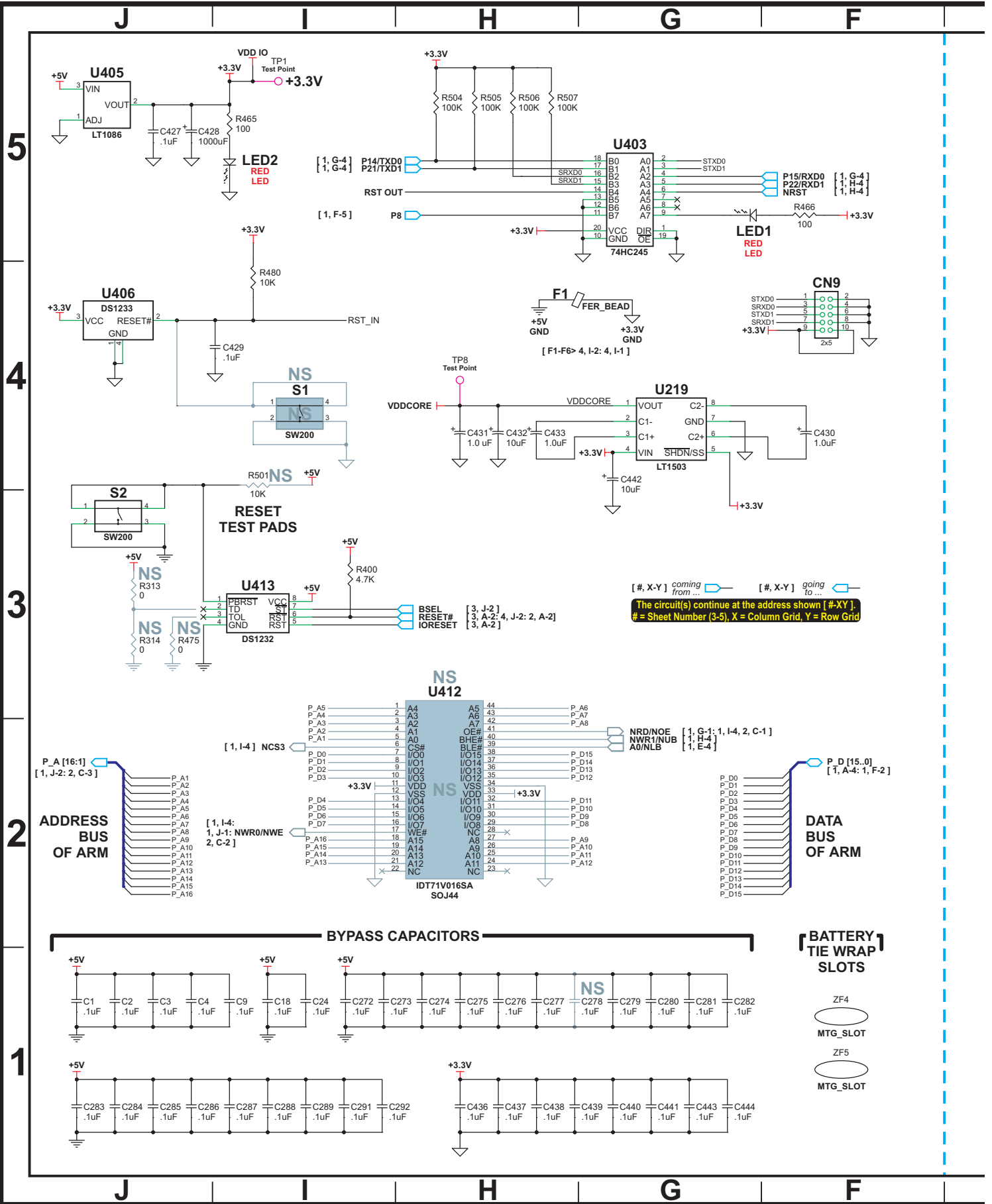

Sec. 5: PCBs

CPU/Sound Board II (with ATMEL Processor) Schematic (Sheet 2 of 4)

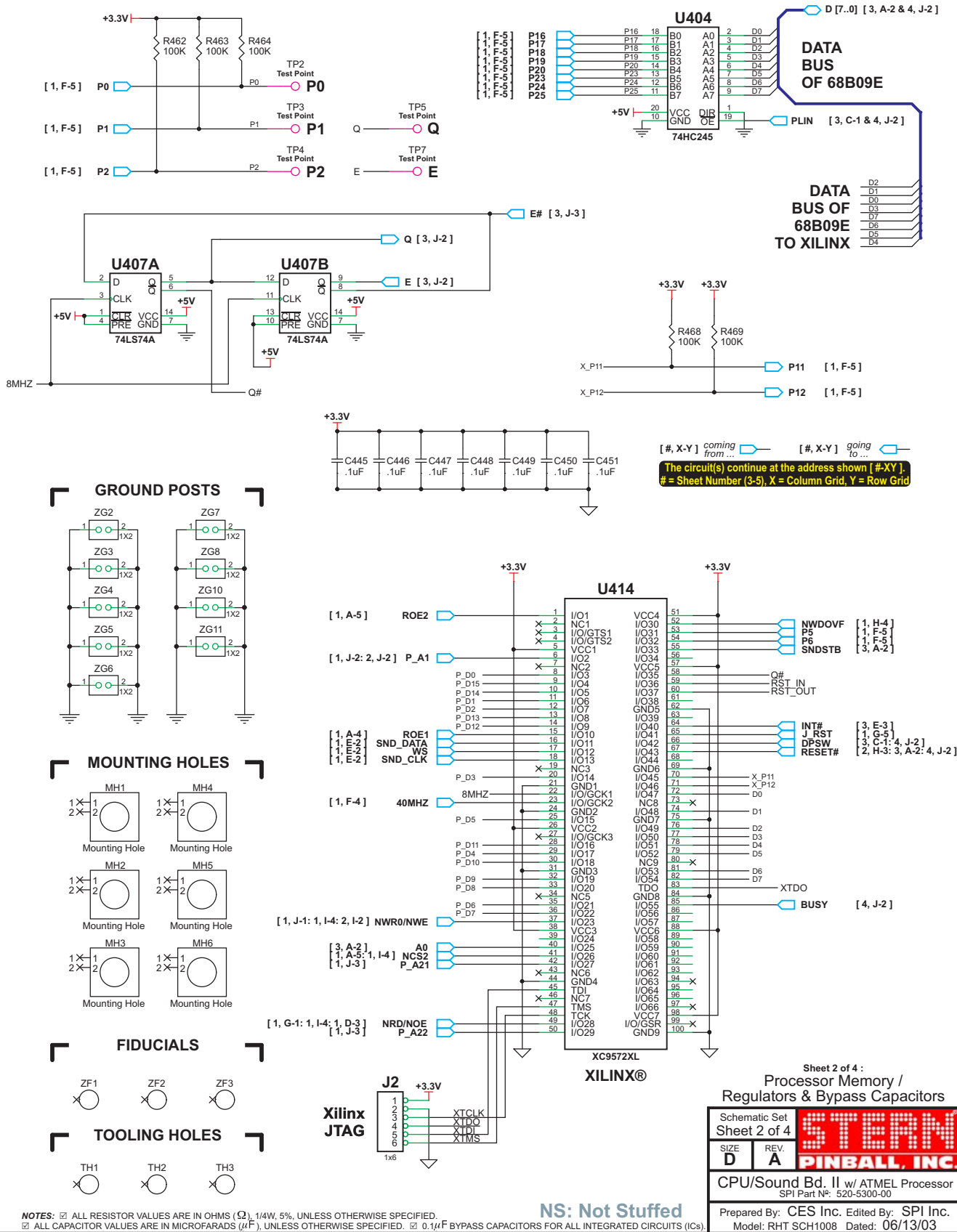

CPU/Sound Board II (with ATMEL Processor) Schematic (Sheet 3 of 4)

[#, X-Y] coming from ... [#, X-Y] going to ...
 The circuit(s) continue at the address shown [#-XY].
 # = Sheet Number (3-5), X = Column Grid, Y = Row Grid

5

4

3

2

1

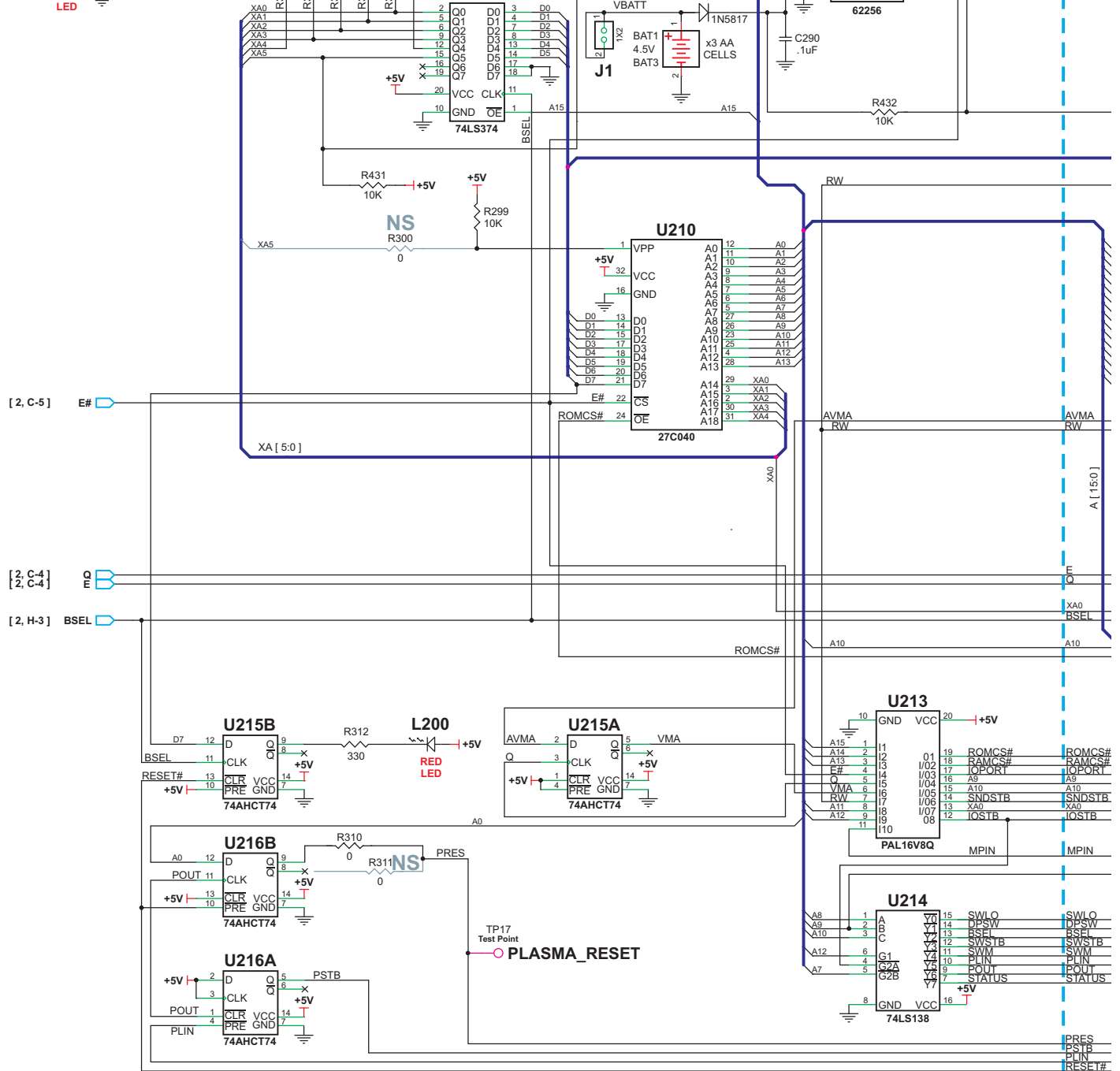
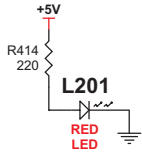

Sec. 5: PCBs

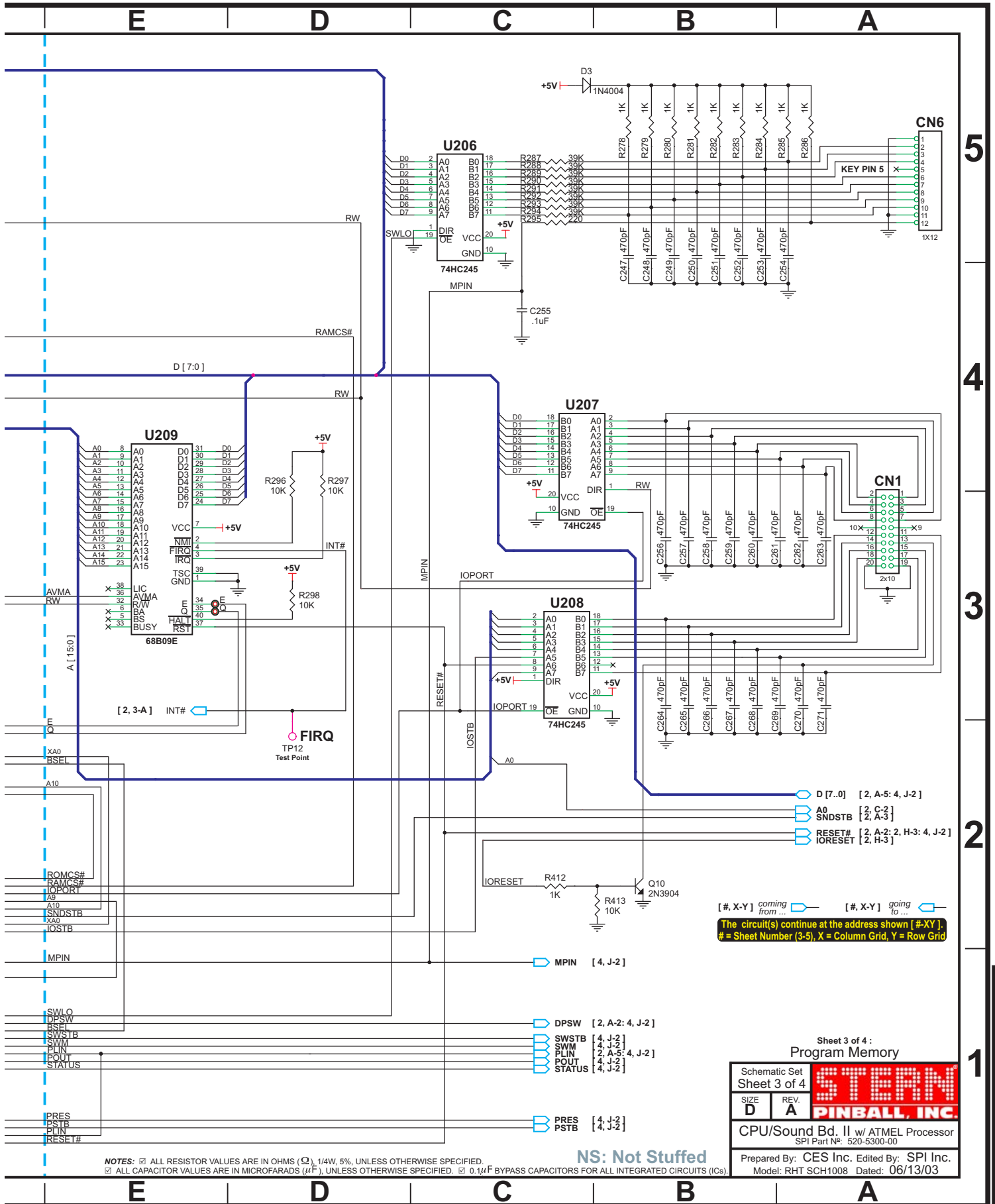

NOTES: □ ALL RESISTOR VALUES ARE IN OHMS (Ω), 1/4W, 5%, UNLESS OTHERWISE SPECIFIED.
 □ ALL CAPACITOR VALUES ARE IN MICROFARADS (μF), UNLESS OTHERWISE SPECIFIED. □ 0.1μF BYPASS CAPACITORS FOR ALL INTEGRATED CIRCUITS (ICs).

NS: Not Stuffed

Sheet 3 of 4:
 Program Memory

Schematic Set	Sheet 3 of 4	STERN
SIZE	REV	
D	A	PINBALL, INC.

CPU/Sound Bd. II w/ ATMEL Processor
 SPI Part N°: 520-5300-00

Prepared By: CES Inc. Edited By: SPI Inc.
 Model: RHT SCH1008 Dated: 06/13/03

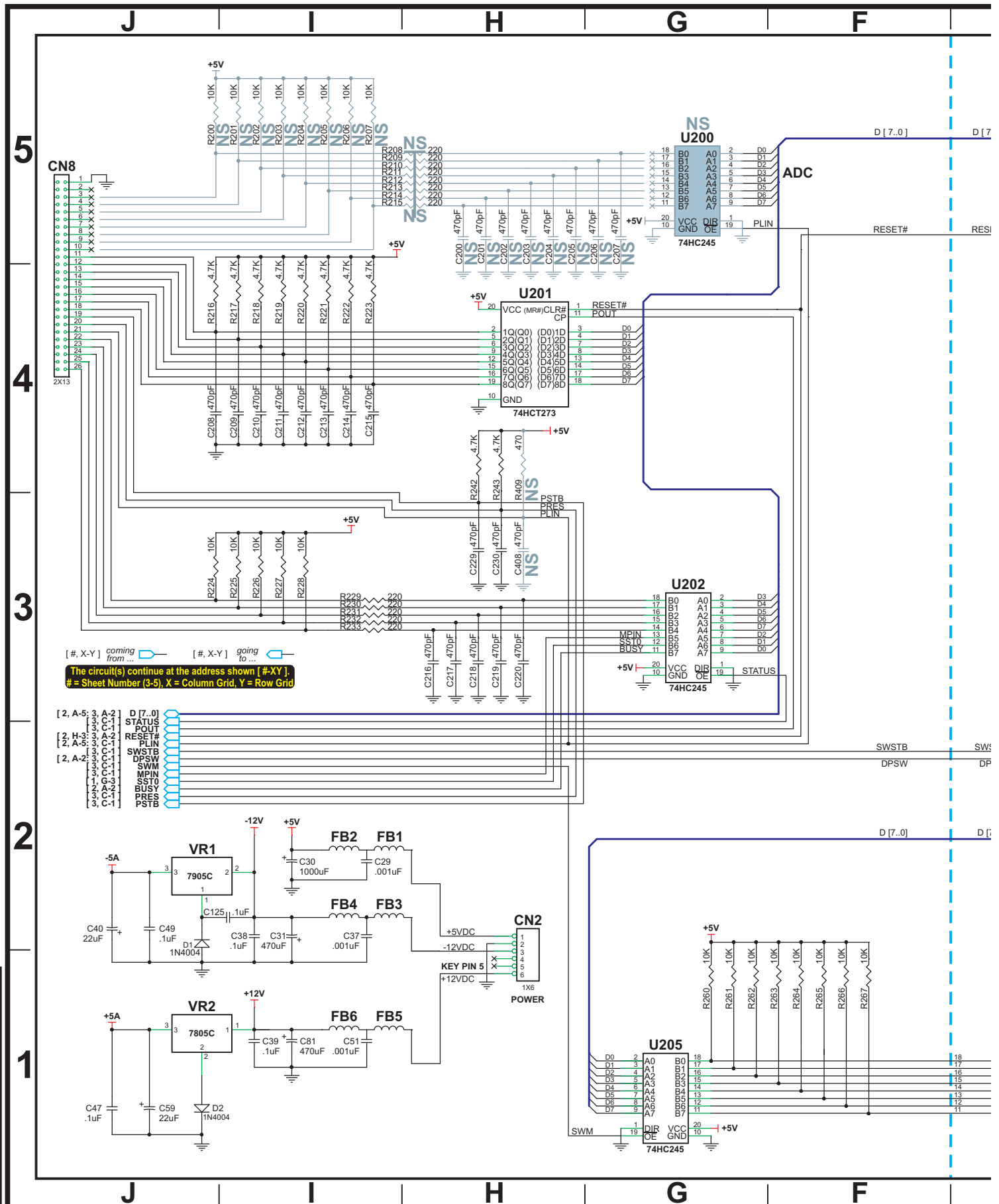

Sec. 5: PCBs

CPU/Sound Board II (with ATMEL Processor) Schematic (Sheet 4 of 4)

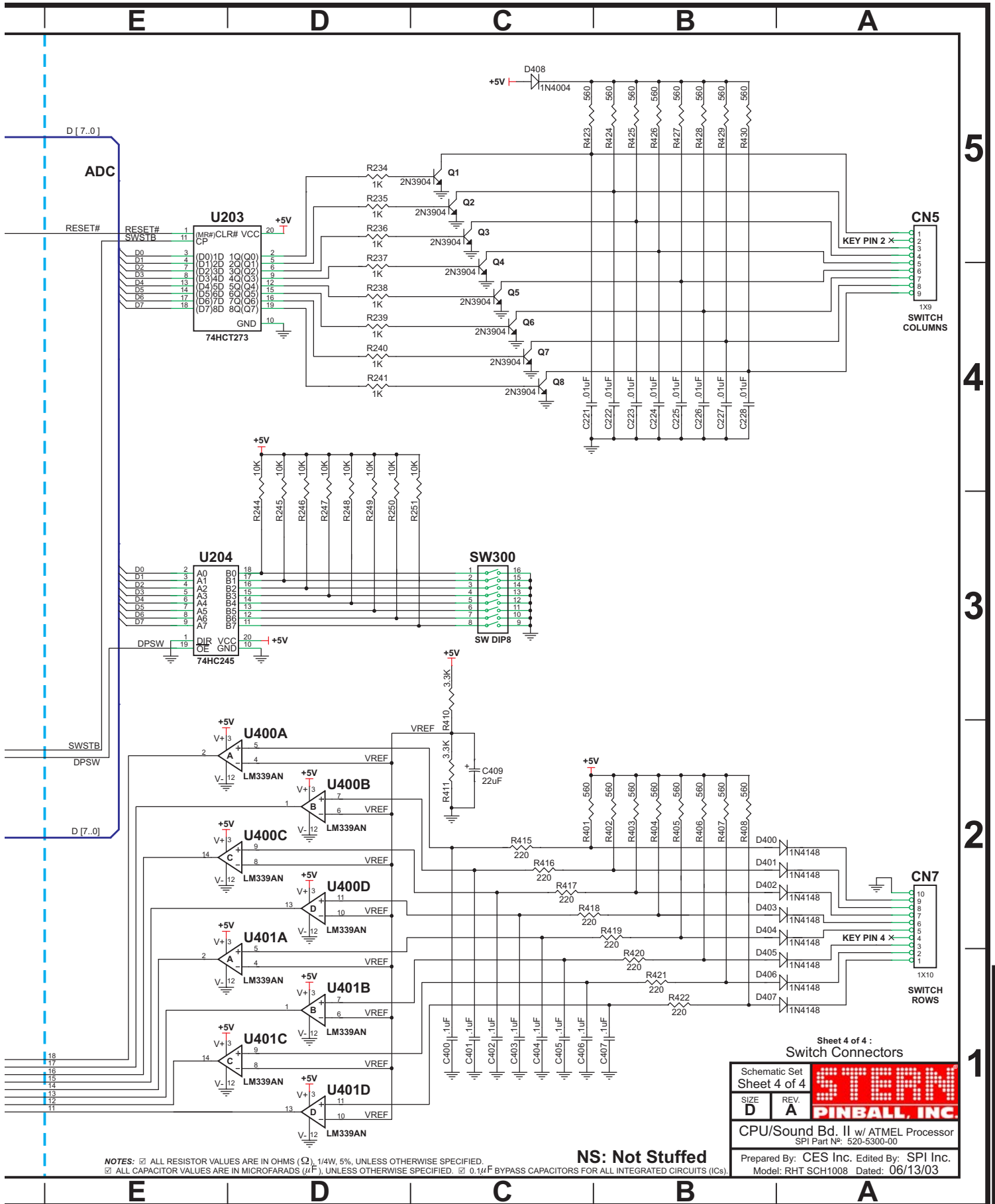

NOTES: □ ALL RESISTOR VALUES ARE IN OHMS (Ω), 1/4W, 5%, UNLESS OTHERWISE SPECIFIED.
 □ ALL CAPACITOR VALUES ARE IN MICROFARADS (μF), UNLESS OTHERWISE SPECIFIED. □ 0.1μF BYPASS CAPACITORS FOR ALL INTEGRATED CIRCUITS (ICs).

NS: Not Stuffed

Sheet 4 of 4 :
 Switch Connectors

Schematic Set		STERN	
Sheet 4 of 4		PINBALL, INC.	
SIZE	REV		
D	A		
CPU/Sound Bd. II w/ ATMEL Processor			
SPI Part N°: 520-5300-00			
Prepared By: CES Inc. Edited By: SPI Inc.			
Model: RHT SCH1008 Dated: 06/13/03			

CPU/Sound Board II (with ATMELE Processor) Component Layout

Test Points (TP):

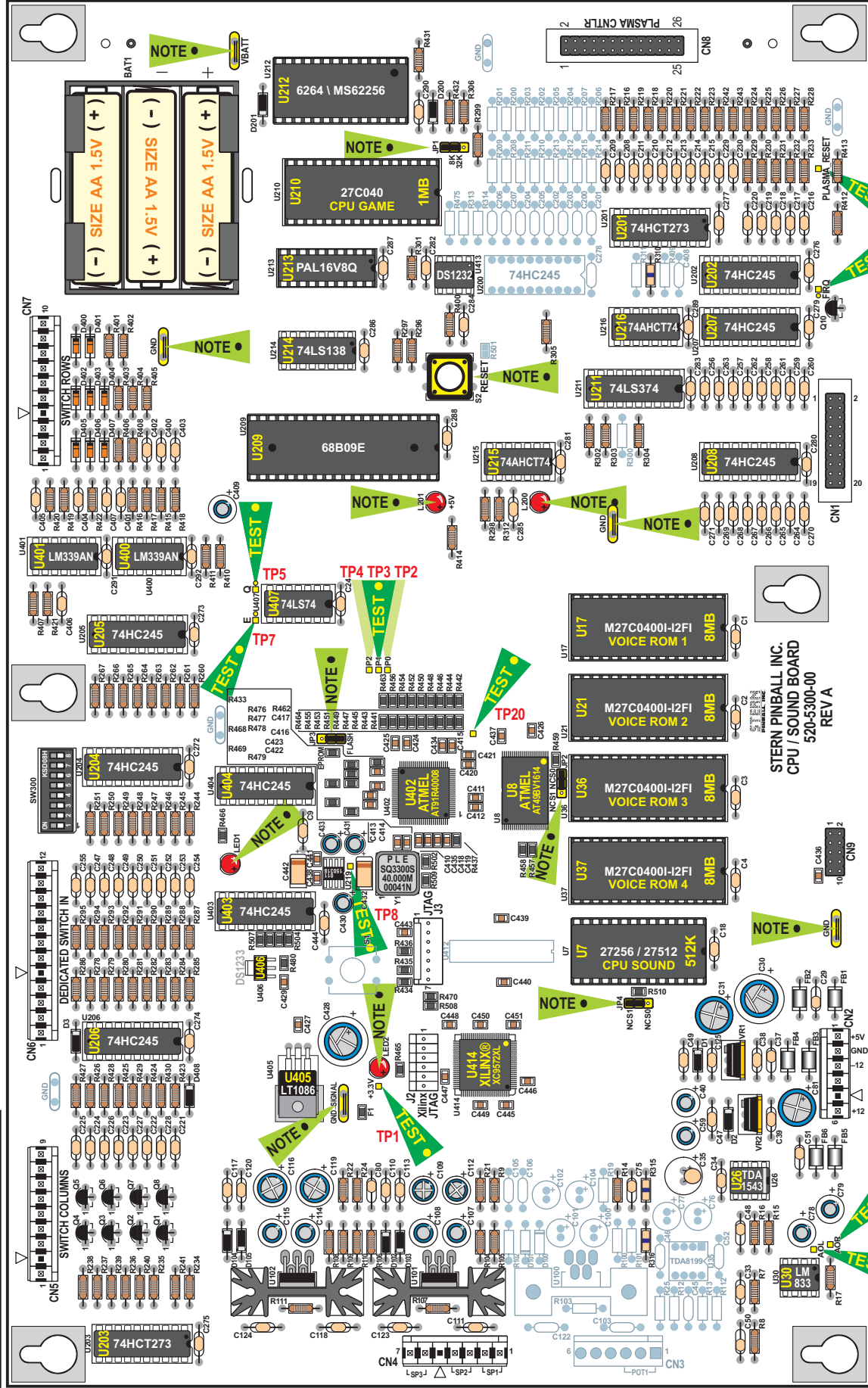

- ← VBATT [3, G-4]
- ← JPI [3, H-5]
- ← PLASMA_RESET TP17: [3, H-1]
- ← FIRQ TP12: [3, D-2]
- ← GND
- ← S2 RESET [2, J-3]
- SW200
- LEDs
- ← L201 / L200 [3, J-5] & [3, H-2]
- GND
- ← Q TP5: [2, C-5]
- ← E TP7: [2, C-5]
- ← P2, PI, PO TP4, TP3, TP2: [2, D-5]
- ← U402 TP20: [1, J-2]
- ← JP3 [1, G-5]
- ← JP2 [1, G-1]
- ← U219 TP8: [2, H-4]
- ← LED1 [2, G-5]
- ← JTAG J3 [1, I-5]
- ← GND
- ← JP4 [1, E-3]
- ← JTAG J2 XILINX [2, C-1]
- ← LED2 [2, I-5]
- ← +3.3V TP1: [2, I-5]
- ← GND_SIGNAL
- ← AOL & AOR TP16: [1, C-1], TP11: [1, D-4]

Sec. 5: PCBs

Actual Board Size
14.87" X 9.125"

CPU/Sound II Board (with Atmel Processor) Parts

ITEM	QTY	PART NUMBER	REF-DESIGNATOR	DESCRIPTION (NS = Not Stuffed)
			CPU/Sound II Board (with Atmel Processor)	Complete PCB Assembly
01	1	520-5300-00	JP1, JP2, JP3, JP4	3-Pin Jumper & 2-Pin Cover
02	4		CN2 (Key Pin-5)	6-Pin, 6PKK156
03	1	045-5015-06	J2 JTAG Xilinx®	6-Pin, ## Header
04	1	045-5015-07	CN4 (Key Pin-5)	7-Pin, 7PKK156
05	1		J3 JTAG	7-Pin, ## Header
06	1	045-5013-00	CN5 (Key Pin-2)	9-Pin, 9PKK156
07	1		CN9	10-Pin, 0.1 Header
08	1	045-5014-01	CN7 (Key Pin-4)	10-Pin, 10PKK156
09	1	045-5015-00	CN6 (Key Pin-5)	12-Pin, 12PKK156
10	1	045-5015-01	CN1	20-Pin, 0.1 Header
11	1	045-5015-26	CN8	26-Pin, 0.1 Header
12	3	125-5043-00	C29, C37, C51	0.001uF (102), Cap.
13	4	125-5039-00	C48, C50, C75, C80	0.0022uF or 2200pF, (222), Cap.
14	8	125-5029-00	C221>C228	0.01uF (103), 100v Cap.
15	52	125-5031-00	C1>C4, C9, C18, C24, C33, C34, C38, C39, C47, C49, C110, C111, C113, C117, C118, C120, C123, C124, C125, C255, C272>C277, C279>C292, C400>C407, C444 (C45, C46, C52, C103, C105, C106, C122, C278: NS)	0.1uF (104), Axial Cer. Cap.
16	3		C430, C431, C433 (near U403, U404)	1.0uF, ##v, Radial Lytic Cap.
17	1	125-5017-00	C35	10uF, 16v, Radial Tant. Cap.
18	4	125-5017-00	C78, C79, C107, C114 (C76, C77, C100: NS)	10uF, 25v-35v, Radial Lytic Cap.
19	2	125-5015-00	C109, C112 (C102, C104: NS)	100uF, 25v, Radial Lytic Cap.
20	1	125-5014-00	C409	22uF, 16v, Radial Lytic Cap.
21	4	125-5020-00	C40, C59, C108, C115 (C101: NS)	22uF, 25v, Radial Lytic Cap.
22	2	125-5012-00	C116, C119	220uF, 25v, Radial Lytic Cap.
23	2	125-5019-00	C31, C81	470uF, 25v, Radial Lytic Cap.
24	39	125-5028-00	C208>C215, C216>C220, C229, C230, C247>C254, C256>C263, C264>C271 (C200>C207, C408: NS)	470pF (471), Cer. Cap.
25	2	125-5037-00	C30, C428	1000uF, 16v, Radial Lytic Cap.
26	17		C427, C429, C436>C441, C443, C445>C451	SMT .1uF Cap.
27	2		C432, C442 (near U403 & U404)	SMT 10uF Cap.
28	9		C411, C414, C416, C419, C420, C422, C424, C434, C435	SMT 47pF Cap.
29	10		C410, C412, C413, C415, C417, C418, C421, C423, C425, C426	SMT 100nF Cap.
30	7	112-5003-00	D1>D3, D102>D105, D408 (D100, D101: NS)	1N4004, Diode
31	2	112-5008-00	D200, D201	1N5817, Diode
32	8	112-0054-00	D400-D407	1N1418, Diode
33	4	165-5099-00	LED1, LED2, L200, L201	LED T1-3/4 DIFFUSER LED
34	3	124-5064-00	R310, R315, R316 (R300, R311, R313, R314, R475: NS)	0Ω Jumper Res. (1-Stripe)
35	2	121-5041-00	R107, R111 (R103: NS)	1 Ω 1/4W Res.
35	20	121-5009-00	R8, R15, R234>R241, R278>R286, R412	1K Ω 1/4W Res.
36	1	121-5018-00	R7	1.5K Ω 1/4W Res.
37	2	121-5043-00	R16, R17 (R25, R112: NS)	2.2K Ω 1/4W Res.
38	2	121-5048-00	R410, R411	3.3K Ω 1/4W Res.
39	12	121-5021-00	R21, R216>R223, R242, R243, R400	4.7K Ω 1/4W Res.
40	36	121-5011-00	R106, R224>R228, R244>R251, R260>R267, R296>R299, R301>R306, R413, R431, R432 (R200>R207, R501: NS)	10K Ω 1/4W Res.
41	3	121-5023-00	R9, R14, R104 (R100, R102: NS)	22K W 1/4W Res.
42	1	121-5022-04	R110	33K Ω 1/4W Res.
43	9	121-5045-00	R108, R287>R294	39K Ω Res.
44	2	121-5032-00	R22, R24	47K Ω 1/4W Res.
45	15	121-5014-00	R229>R233, R295, R414>R422 (R208>R215: NS)	220 Ω 1/4W Res.
46	1	121-5036-00	R312	330 Ω 1/4W Res.
47	2	121-5046-01	R105, R109 (R101, R409: NS)	470 Ω 1/4W Res.
48	16	121-5047-00	R401>R408, R423>R430	560 Ω 1/4W Res.
49	1		F1	SMT xx Res.
50	4		R434, R435, R436, R508	SMT 1K Ω Res.
51	1		R480	SMT 10K Ω Res.
52	2		R502, R509	SMT 33 Ω Res.
53	3		R465, R466, R470	SMT 100 Ω Res.
54	35		R433, R437, R441>R459, R462>R464, R468, R469, R476>R479, R504>R507, R510	SMT 100K Ω Res.
55	9	110-0069-00	Q1-Q8, Q10	2N3904, Transistor
56	1		U402	ATMEL , AT91R40008
57	1		U8	ATMEL , AT49BV1614
58	1		U414	XILINX® , XC9572XL
59	1		U7	512K EPROM Sound (27512)
60	1	(See Pg. DR. Ⓢ Table)	U210 (32-Pin, IC Socket, 077-5217-00)	1MB EPROM CPU Game (27C040)
61	4	(See Pg. DR. Ⓢ Table)	U17, U21, U36, U37 (32-Pin, IC Socket, 077-5217-00)	8MB EPROM Voice 1-4 (M27C04001-12FI)
62	1		U213 (BLUE DOT)	PAL16V8Q (Programmed) BLUE DOT
63	1	965-6504-00	U212 (28-Pin, IC Dip Socket, 077-5208-00)	6264/MS62256 (MS6264A) (28-Pin)
64	1	105-5046-00	U209 (40-Pin, IC Socket, 077-5209-00)	68B09E (40-Pin)
65	2	100-5015-00	U215, U216	74AHC74 (14-Pin)
66	8	100-0338-00	U202, U204, U205, U206, U207, U208, U403, U404 (U200: NS)	74HC245 (20-Pin)
67	2	100-5012-00	U201, U203	74HCT273 (20-Pin)
68	1	100-0037-00	U407	74LS74 (14-Pin)
69	1	100-0148-00	U214	74LS138 (16-Pin)
70	1	100-0064-00	U211	74LS374 (20-Pin)
71	1		U406	3.3v Watchdog, DS1233 (3-Pin)
72	1	100-5023-00	U413	5.0v Watchdog, DS1232 (8-Pin)
73	1		U219	1.8v Volt. Regulator LT1503 (8-Pin)
74	1		U405	3.3v Volt. Regulator LT1086 (3-Pin)
75	1	124-5002-00	VR1	-5v Regulator, LM7905CT
76	1	124-5001-00	VR2	+5v Regulator, LM7805CT
77	2	100-0377-00	U400, U401	LM339AN (14-Pin)
78	1	100-0375-00	U30	LM833 (8-Pin)
79	1	100-5018-00	U26	TDA1543 (8-Pin)
80	2	100-5016-20	U101, U102 (U100: NS)	TDA2030A (5-Pin)
81	1		Y1	40MHz Clock PLE SQ3300S
82	1	181-5002-00	SW300	Dip Switch 8-Pos., (KSD08H Black)
83		n/a	FB1>FB6	Ferrite Bead
84		535-5000-10	HS2, HS3, (HS1: NS) (over U101, U102)	Heat Sink (AAVID 531102)
85	1		S2 (Reset)	Push-Button Switch (B3F4000)
86	1	545-5685-00	BAT1 HOLDER (Always replace all 3, Size AA 1.5v Cells, with new ones, when required)	

* Surface Mounts (SMT) are not listed.

* Surface Mounts (SMT) are not listed.

Test Point Wire (24ga.) Loops:
 VBATT, GND (near CN7),
 GND (near CN9), GND (near L200),
 GND_SIGNAL (near U405)

Test Point Pads:
 TP1>TP5, TP7, TP8, TP11,
 TP12, TP16, TP17, TP20

If a part is required where a part number is not provided, call Tech. Support (see back of cover).

Sec. 5: PCBs

**CPU Section:**

The **CPU** is a **68B09E (U209)** with up to 8 MBytes of **CPU Code Space (U210)**. The **CPU** code is bank selected by the use of **U211** and each bank consists of 16 KBytes. 8 KBytes of **RAM (U212)** is available to the **CPU**. The **RAM** is battery backed and has a write protected area. Battery back up is accomplished by **3-AA Cells (BAT1)** which have a **TEST POINT VBATT** to check the battery voltage status. The write protected area consists of 512 Bytes used for storing game settings. This section of **RAM** can only be written to when the coin door is open. The Coin Door switch comes into the **CPU** on **CN6-12** and is fed into the address decoding **PAL U213**. When this memory protect signal is low writes to the protected **RAM** area are prohibited. Address decoding for the system is accomplished by one **PAL U213** and one 1-of-8 decoder **U214**.

A watchdog is used to monitor the **CPU** and the 5v supply. If the 5v supply is below 4.75 the watchdog will hold the **CPU/Sound Board & I/O Board** in *reset*. The watchdog must be fed at a rate of **250ms** or faster. The signal used to feed the watchdog comes from the EPROM Bank select signal used to load **U211**. The **CPU** has a timer interrupt used as a heartbeat for the system this signal comes from counter **U2**. The clock for this counter is the **CPU Q CLOCK**. Clearing the timer interrupt is done by reading the **DIP Switch**. The timer interrupt can be observed at **TEST POINT FIRQ**. In normal operation "**FIRQ**" should be toggling at a rate of 976Hz.

The **I/O** Interface **CN1** is buffered by two (2) **HC245** Chips (**U207 & U208**). The **CPU's** reset line is buffered by **Q10** and fed over to the **I/O** through **CN1**. An **I/O Strobe Signal** is fed through **CN1-15** and is used to notify the **I/O** that a valid address is being sent.

Switches:

The Switch Matrix consists of eight (8) **2N3904** Transistors(**Q1-Q8**) which pull one of 8 strobes 'low' to *activate* a Single Column of switches. The *Switch Return Signals* are fed into **CN7** [SWITCH ROWS] and are highly filtered and compared to a 2.5v reference voltage. The *Switch Return Voltage* must be below 2.5v to make a *Valid Switch Closure*. If *false switches* are appearing, check that none of the **2N3904** Transistors are permanently pulling the *strobe line low*. Only one strobe from **CN5** [SWITCH COLUMNS] should be *low at any time*. **CN6** [DEDICATED SWITCH IN] is a *Dedicated Bank of Input Switches*. Switches connected to **CN6** are connected to ground instead of a strobe and may be read at any time.

Plasma Interface:

The data path for communication to and from the **Plasma Controller Board** is 8 bits wide. There are separate *Input* and *Output Busses*. The *Input Bus* from the Plasma Controller to the **CPU/Sound Board** comes in on **CN8** [PLASMA CONTROL]-Pins 3-10 and is fed into **U200** for input to the **CPU's Data Bus**. Data going out to the controller comes from the **CPU's Data Bus** through **U201** and onto **CN8-Pins 11-18**. Status back from the Plasma Controller comes in on **CN8-Pins 22-26** and is fed into **U202** for input to the **CPU's Data Bus**. Two control signals that go out to the Plasma Controller are **PRES** [PLASMA RESET] and **CN8-Pin 19** [PSTB - *Plasma Strobe*]. The Plasma Reset is software controllable through **U216/B** and also has a test point "Plasma Reset". The *Plasma Strobe Signal* to the controller is generated from **U216/A** and is *used to latch data* into the Plasma Controller.

Sound Section:

The audio section consists of a **BSMT SOUND CHIP U9** Sound (Voice) EPROMs (**U17 U21 U36 U37**) **68B09E U6** and Sound Code EPROM **U7**. The **BSMT** latches sound EPROM addresses in **U13 & U12** for output to the Sound EPROMs. Sound Data from the EPROMs is read through **U19** to the **BSMT**. The EPROMs are bank selected by **U22**. When the **BSMT** has sound data to be played out to the speakers it loads 16 bits into a 16 bit shift register made up of **U24 & U23**. The data stream from the shift register is serially shifted into a stereo 16 bit *Digital to Analog Converter (DAC, U26)*. When the system is operating properly the ws (word select) input of the **DAC** will be toggling. The ws input is used to latch the right and left channel sound data into the **DAC**. If the ws line is not oscillating no analog signal will come out of the **DAC**. The **DAC** outputs are a controlled current source. These outputs are converted to a voltage by an operational amplifier **U30** to form the analog signal. **TEST POINTS AOR** and **AOL** are the outputs of the operational amplifier. These outputs are then fed directly into the power amplifiers (**TDA2030A**) or optionally into an analog volume control chip **U35** for a potentiometer volume control. The analog section has its own +5v & -5v derived from **VR1 & VR2**. These separate supply voltages are for the **DAC U26** Operational Amplifier **U30** and analog volume control **U35**.

Sound calls are made from the **CPU's 68B09E U209** to the sound section by latching data into **U5**. The sound section's **CPU 68B09E (U6)** reads in this data and handles the interfacing to the **BSMT**.

Other Test Points:

E & Q - The **CPU** signals for both **68B09E** processors. Should be at 2Mhz with **Q** leading **E** by **500 nsec**.

24Mhz - The oscillator used for the **BSMT** & derivation of **E & Q**.

SND-FIRQ - The sound sections **CPU Interrupt**.

6Mhz - This clock is generated internally on the **BSMT** and is used for shifting the data samples into the **DAC**.

W6 Jumper - This jumper must be installed for games that use **8MB** Sound EPROMs (**U17 U21 U36 U37**). For games which use **4MB** Sound EPROMs this jumper is not installed but will operate on boards with **W6** installed.



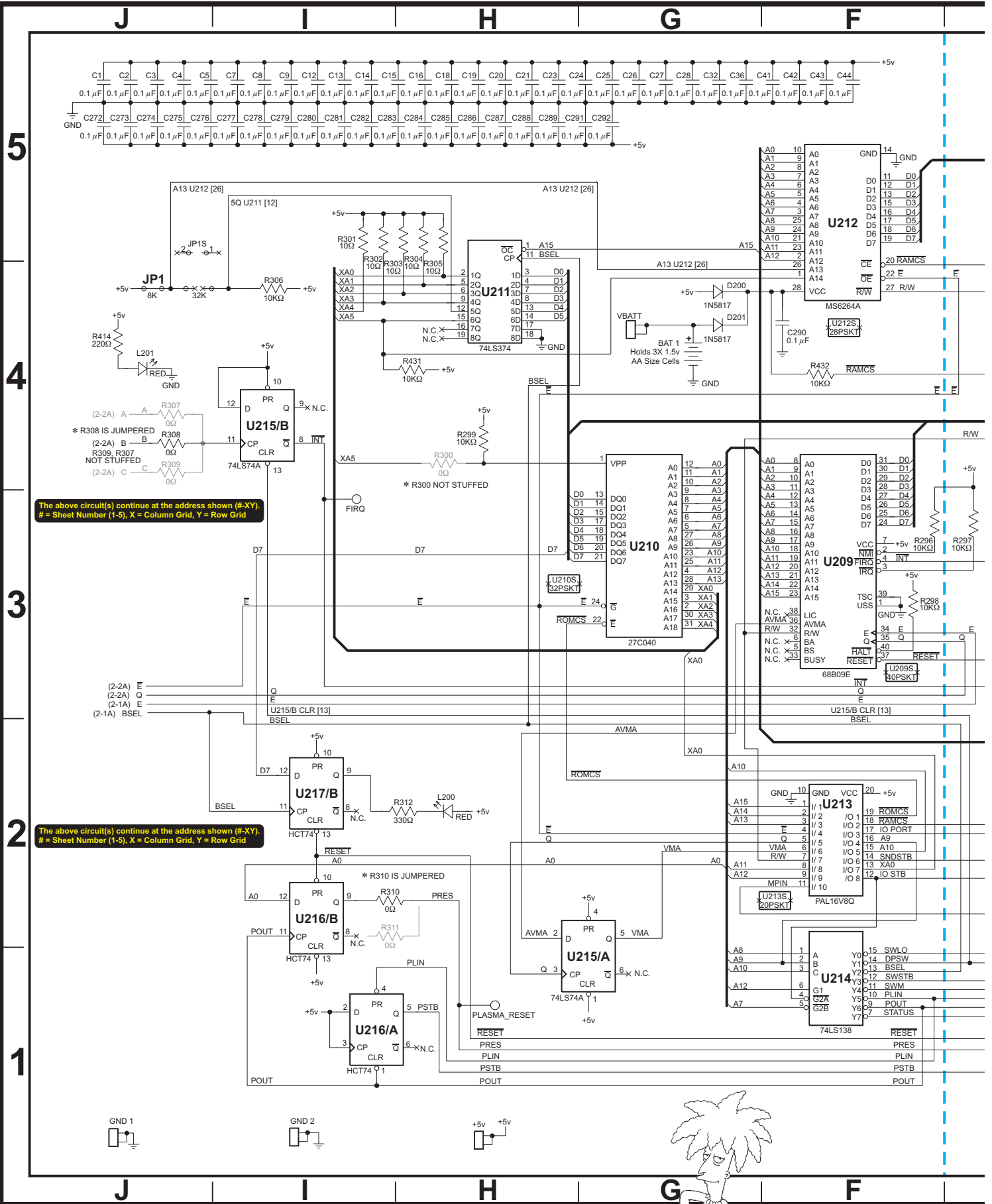

Sec. 5: PCBs

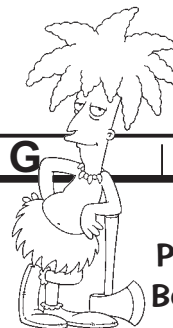

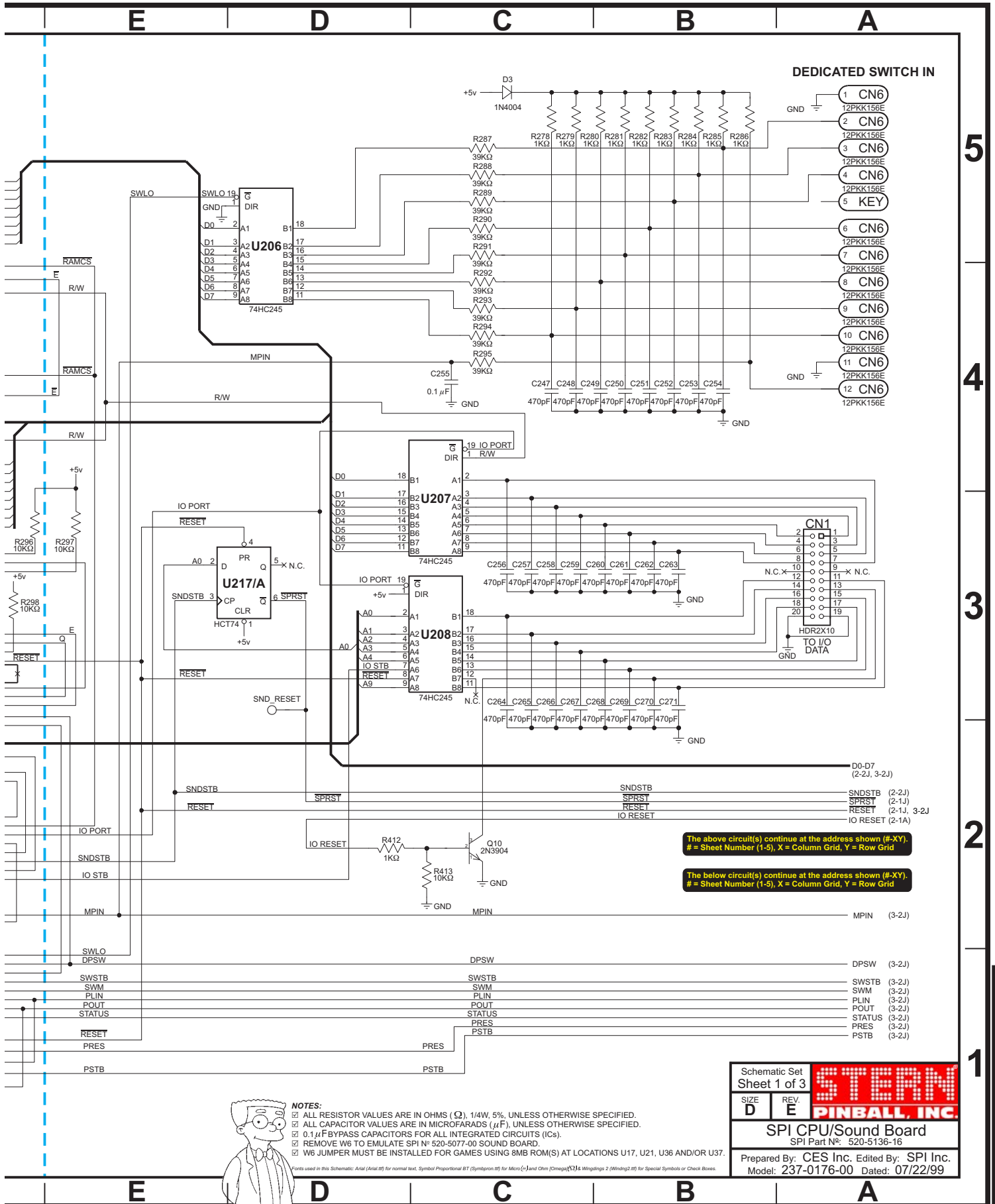

The above circuit(s) continue at the address shown (#-XY).
= Sheet Number (1-5), X = Column Grid, Y = Row Grid

The below circuit(s) continue at the address shown (#-XY).
= Sheet Number (1-5), X = Column Grid, Y = Row Grid



- NOTES:**
- ALL RESISTOR VALUES ARE IN OHMS (Ω), 1/4W, 5%, UNLESS OTHERWISE SPECIFIED.
 - ALL CAPACITOR VALUES ARE IN MICROFARADS (μF), UNLESS OTHERWISE SPECIFIED.
 - 0.1μF BYPASS CAPACITORS FOR ALL INTEGRATED CIRCUITS (ICs).
 - REMOVE W6 TO EMULATE SPI N° 520-5077-00 SOUND BOARD.
 - W6 JUMPER MUST BE INSTALLED FOR GAMES USING 5MB ROM(S) AT LOCATIONS U17, U21, U36 AND/OR U37.
- Fonts used in this Schematic: Arial (Arial.ttf) for normal text, Symbol Proportional BT (Symbolpro.ttf) for Micro (μ) and Ohm (Ω) & Wingsdings 2 (Wingsdngs 2) for Special Symbols or Check Boxes.

Schematic Set		STERN
Sheet 1 of 3		
SIZE	REV	PINBALL, INC.
D	E	
SPI CPU/Sound Board		
SPI Part N°: 520-5136-16		
Prepared By: CES Inc. Edited By: SPI Inc.		
Model: 237-0176-00 Dated: 07/22/99		



Sec. 5: PCBs

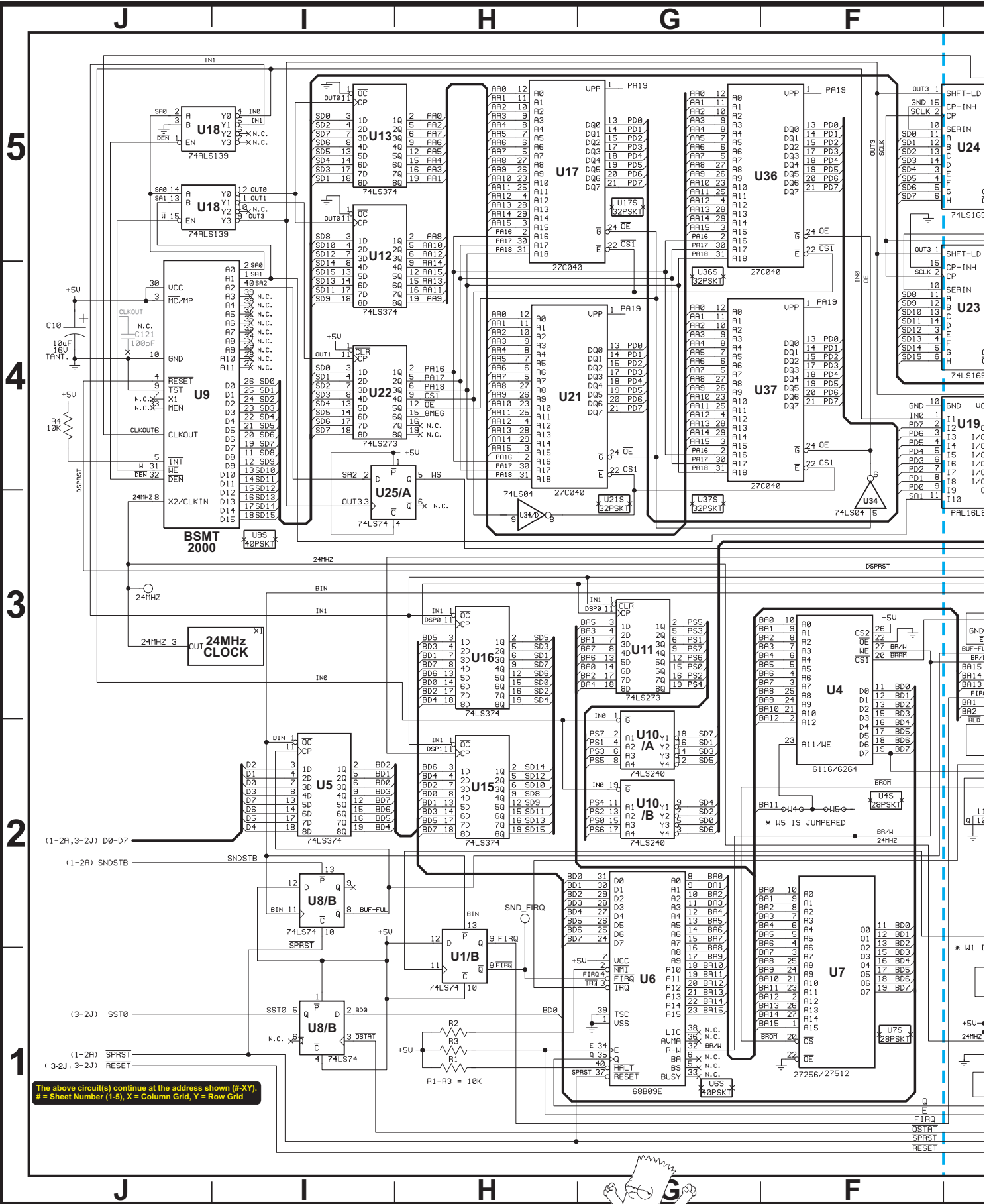

Sec. 5: PCBs



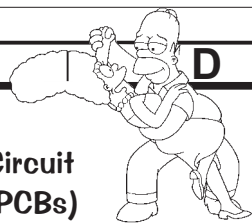
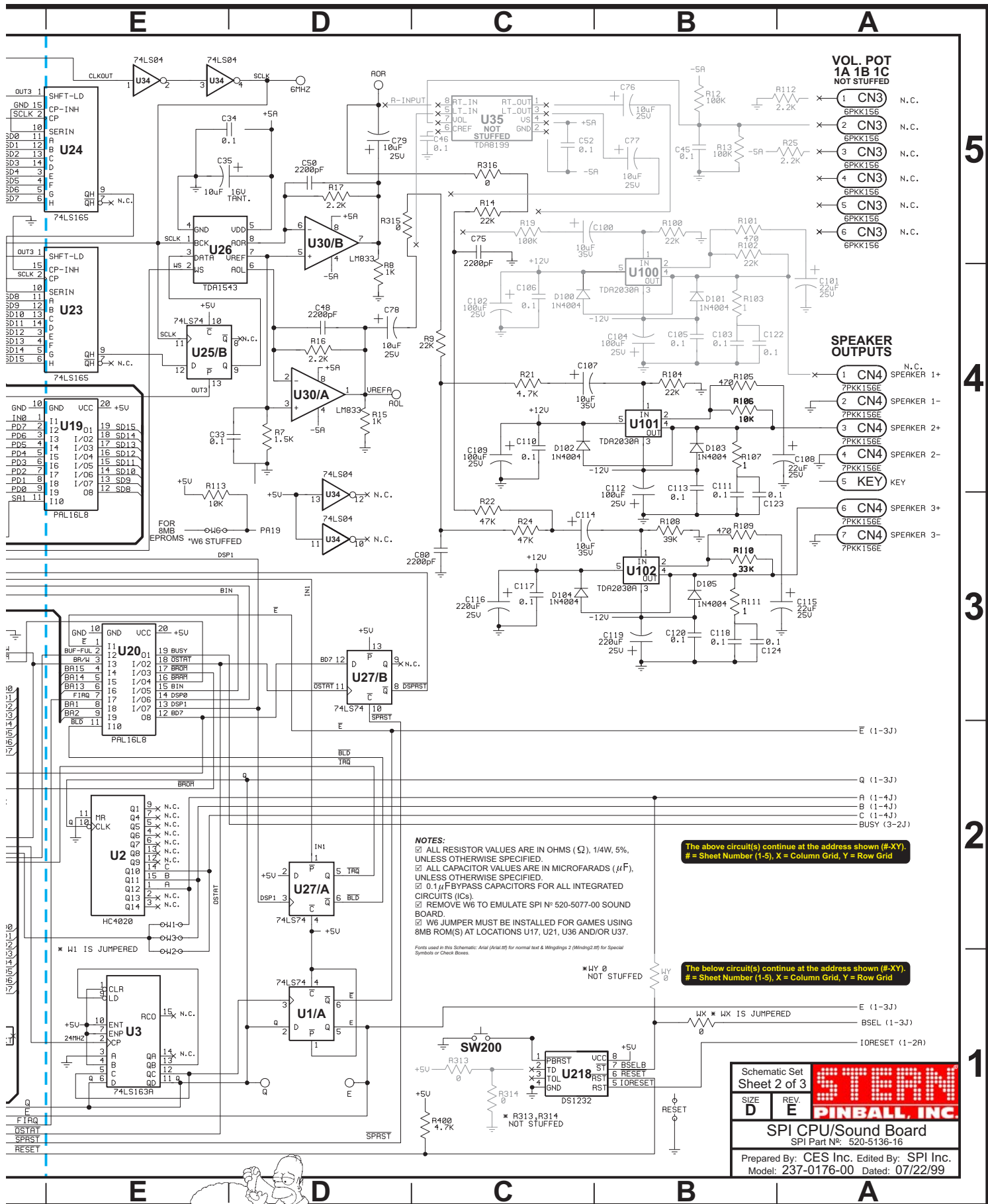

Schematic Set		STERN	
Sheet 2 of 3		PINBALL, INC.	
SIZE	REV	SPI CPU/Sound Board	
D	E	SPI Part N°: 520-5136-16	
Prepared By: CES Inc. Edited By: SPI Inc.			
Model: 237-0176-00 Dated: 07/22/99			

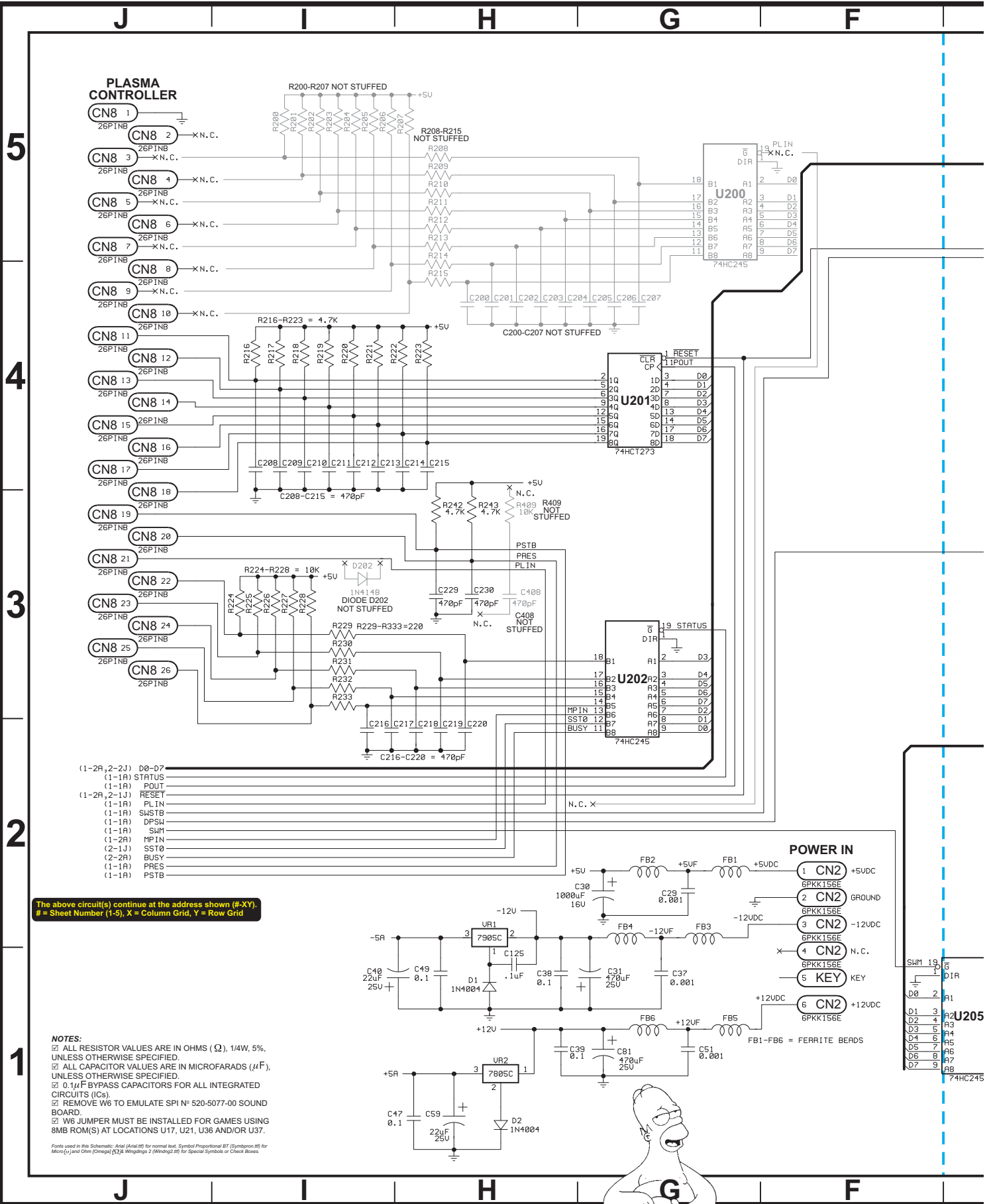

The above circuit(s) continue at the address shown (#-XY), # = Sheet Number (1-5), X = Column Grid, Y = Row Grid

- NOTES:**
- ☑ ALL RESISTOR VALUES ARE IN OHMS (Ω), 1/4W, 5%, UNLESS OTHERWISE SPECIFIED
 - ☑ ALL CAPACITOR VALUES ARE IN MICROFARADS (μF), UNLESS OTHERWISE SPECIFIED.
 - ☑ 0.1μF BYPASS CAPACITORS FOR ALL INTEGRATED CIRCUITS (ICs).
 - ☑ REMOVE W6 TO EMULATE SPI N° 520-5077-00 SOUND BOARD.
 - ☑ W6 JUMPER MUST BE INSTALLED FOR GAMES USING 8MB ROM(S) AT LOCATIONS U17, U21, U36 AND/OR U37.
- Symbols used in this Schematic: Aerial (Aerial) for normal text, Symbol Proportional BT (Symbolproportional BT) for Mount(-) and Open (Open) (D3-D6) Wiretraps (Wiretraps) for Special Symbols or Check Boxes.

Sec. 5: PCBs

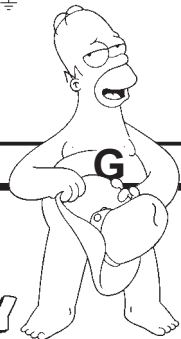

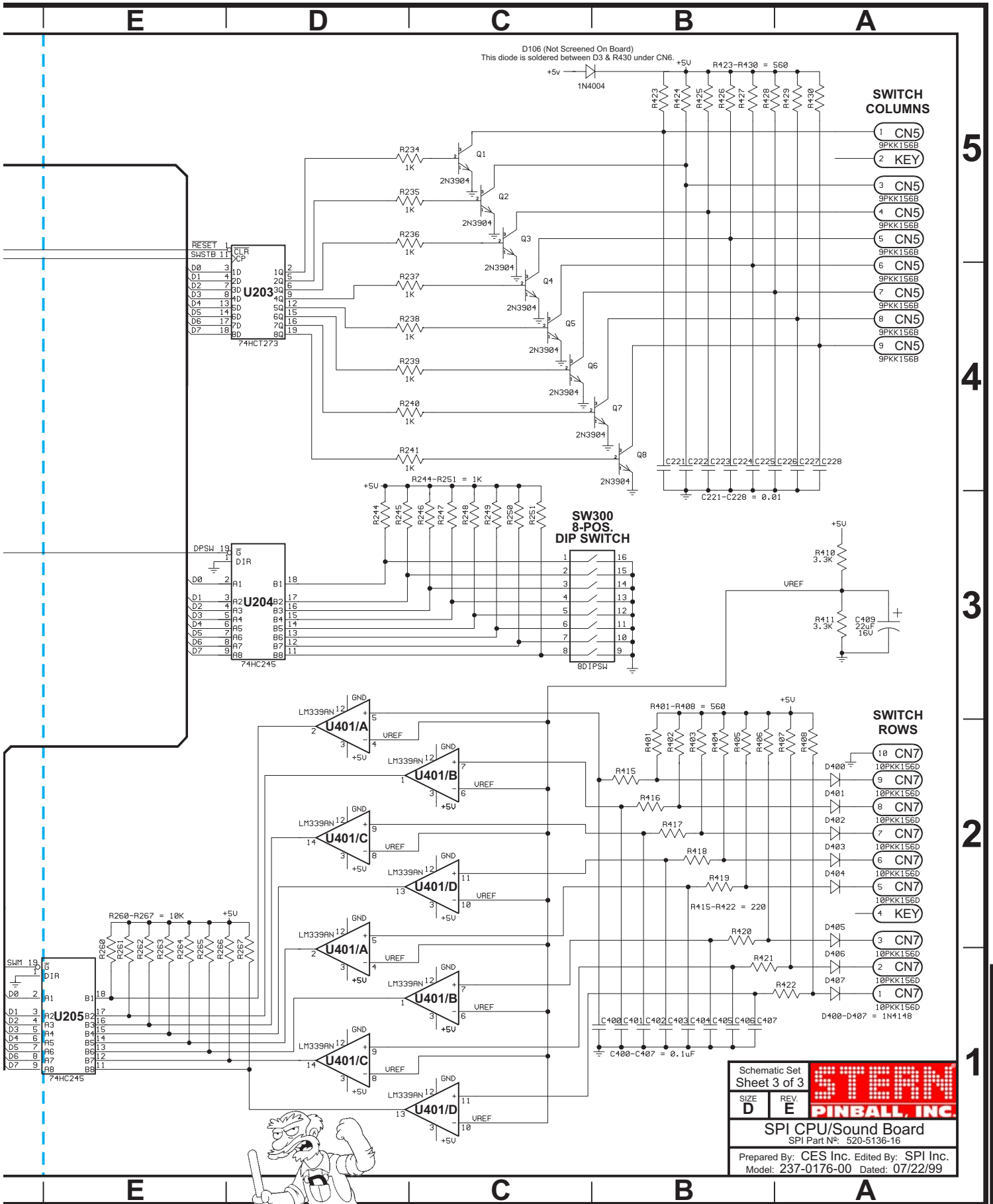

Schematic Set		STERN	
Sheet 3 of 3			
SIZE	REV	PINBALL, INC.	
D	E		
SPI CPU/Sound Board			
SPI Part No: 520-5136-16			
Prepared By: CES Inc. Edited By: SPI Inc.			
Model: 237-0176-00 Dated: 07/22/99			

Sec. 5: PCBs

CPU/Sound Board Component Layout

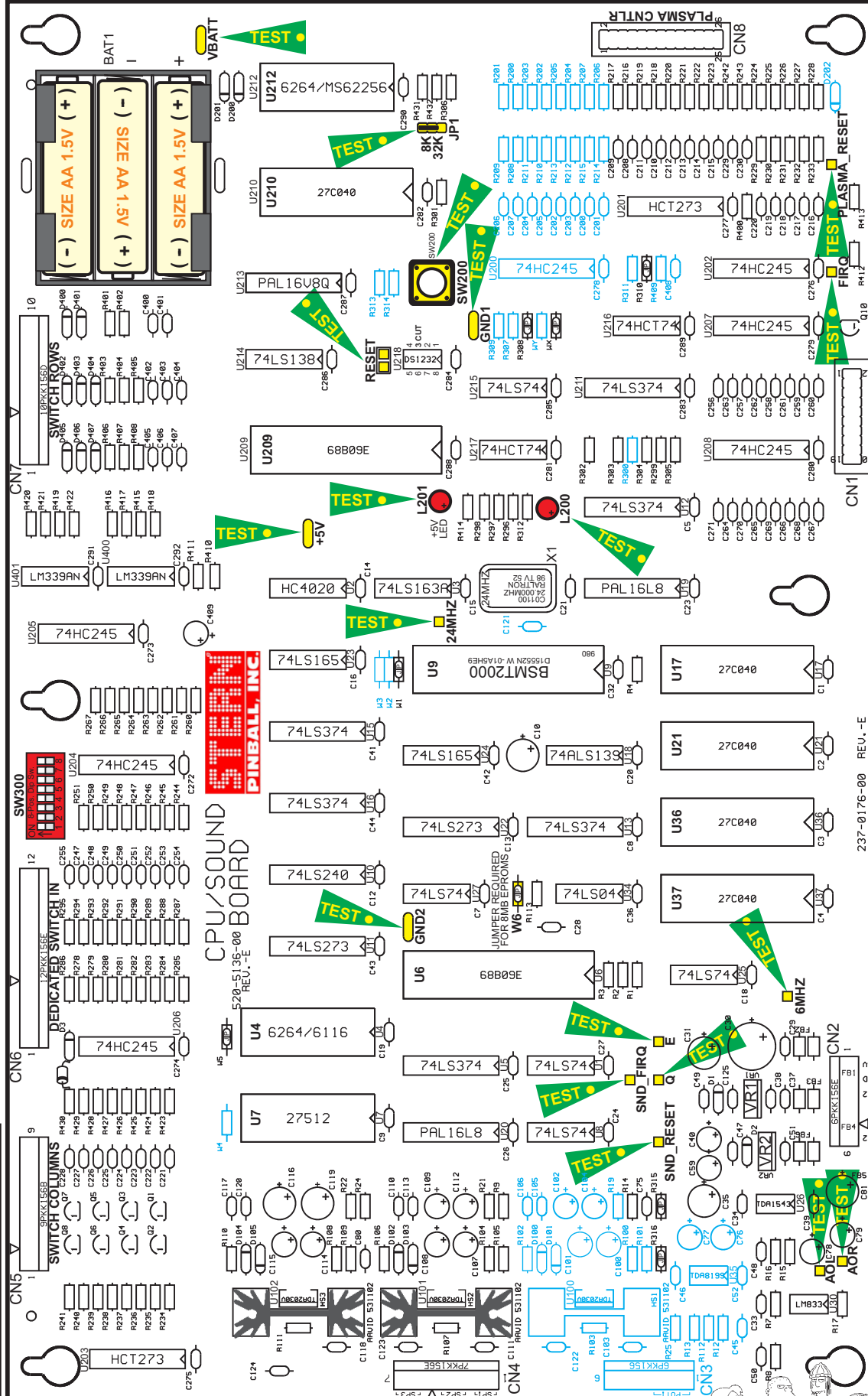

- Test Points:**
- ← VBATT
 - ← 8K/32K JUMPER JP1
 - ← PLASMA_RESET
 - ← FIRQ SW200
 - ← GND1
 - ← RESET
 - LEDs :
 - ← L201+5v & L200
 - ← +5V
 - ← 24MHZ
 - ← 237-0176-00 REV. E
 - REQUIRED FOR 8MB EPROM USE**
 - ← W6 JUMPER
 - ← GND2
 - ← 6MHZ
 - ← E
 - ← SND_FIRQ & Q
 - ← SND_RESET
 - ← AOL & AOR

Sec. 5: PCBs



Actual Board Size
14.67" X 9.125"

CPU/Sound Board Parts

ITEM	QTY	PART NUMBER	REF-DESIGNATOR	DESCRIPTION (NS = Not Stuffed)
—	1	520-5136-16	CPU/Sound Board Mono (FCC FEB98)	Complete PCB Assembly
01	1	545-5685-00	BAT1 HOLDER (Always replace all 3, Size AA 1.5v Cells, with new ones, when required)	
02	79	125-5031-00	C1, C2, C3, C4, C5, C7, C8, C9, C12, C13, C14, C15, C16, C18, C19, C20, C21, C23, C24, C25, C26, C28, C32, C33, C34, C36, C38, C39, C41, C42, C43, C44, C47, C49, C110, C111, C113, C117, C118, C120, C123, C124, C125, C255, C272, C273, C274, C275, C276, C277, C279, C280, C281, C282, C283, C284, C285, C286, C287, C288, C289, C290, C291, C292, C400>C401, C402>C404, C405>C407 (C45, C46, C52, C103, C105, C106, C122: NS)	0.1uF (104), Axial Cer. Cap.
03	2	125-5017-00	C10, C35	10uF, 16v, Radial Tant. Cap.
04	3	125-5043-00	C29, C37, C51	0.001uF, (102), Cap.
05	1	125-5037-00	C30	1000uF, 16v, Radial Lytic Cap.
06	2	125-5019-00	C31, C81	470uF, 25v, Radial Lytic Cap.
07	4	125-5020-00	C40, C59, C108, C115 (C76, C77, C101: NS)	22uF, 25v, Radial Lytic Cap.
08	4	125-5039-00	C48, C50, C75, C80	0.0022uF, (222), Cap.
09	6	125-5017-00	C78, C79, C107, C114 (C100: NS)	10uF, 25v-35v, Radial Lytic Cap.
10	2	125-5015-00	C109, C112 (C102, C104: NS)	100uF, 25v, Rad. Ltc. Cap.
11	2	125-5012-00	C116, C119	220uF, 25v, Radial Lytic Cap.
12	0	125-5038-00	(C121: NS)	100pF (101), Cap.
13	44	125-5028-00	C208>C215, C216>C220, C229, C230, C247>C254, C256>C263, C264>C271 (C200>C207: NS)	470pF, (471), Cer. Cap.
14	8	125-5029-00	C221>C228 (C408: NS)	0.01uF, (103), 100v Cap.
15	1	125-5014-00	C409	22uF, 16v, Radial Lytic Cap.
16	1	045-5015-01	CN1	20-Pin, 0.1 HEADER
17	1	045-5015-06	CN2 (Key Pin-5) (CN3: NS)	6PKK156
18	1	045-5015-07	CN4 (Key Pin-5)	7PKK156
19	1	045-5013-00	CN5 (Key Pin-2)	9PKK156
20	1	045-5015-00	CN6 (Key Pin-5)	12PKK156
21	1	045-5014-01	CN7 (Key Pin-4)	10PKK156
22	1	045-5015-26	CN8	26-Pin, 0.1 HEADER
23	7	112-5003-00	D1, D2, D3, D102, D103, D104, D105 (D100, D101: NS)	1N4004, Diode
24	2	112-5008-00	D200, D201	1N5817, Diode
25	8	112-0054-00	D400, D401, D402>D404, D405>D407 (D202: NS)	1N4148, Diode
26	6	n/a	(FB1)-FB2, FB3-(FB4), (FB5)-FB6	Ferrite Bead (if required, call Tech Support)
27	1	165-5099-00	L200, L201	LED T1-3/4 DIFFUSER LED
28	10	110-0069-00	Q1>Q8, Q10 (Q9 Not Used)	2N3904, Transistor
29	36	121-5011-00	R1>R3, R4, R106, R113, R224>R228, R244>R251, R260>R267, R296>R298, R299, R301, R302>R305, R306, R413, R431>R432 (R200>R207, R409: NS)	10K Ω 1/4W Res.
30	1	121-5018-00	R7	1.5K Ω 1/4W Res.
31	5	121-5023-00	R9, R14, R104, (R100, R102: NS)	22K Ω 1/4W Res.
32	20	121-5009-00	R15, R8, R234>R241, R278>R286, R412	1K Ω 1/4W Res.
33	2	121-5043-00	R16, R17 (R25, R112: NS)	2.2K Ω 1/4W Res.
34	2	121-5032-00	R22, R24	47K Ω 1/4W Res.
35	2	121-5046-01	R105, R109 (R101: NS)	470 Ω 1/4W Res.
36	2	121-5041-00	R107, R111 (R103: NS)	1 Ω 1/4W Res.
37	9	121-5045-00	R108, R287>R294	39K Ω Res.
38	12	121-5021-00	R21, R216>R223, R242, R243, R400	4.7K Ω 1/4W Res.
39	15	121-5014-00	R229>R233, R295, R414, R415>R422 (R208>R215: NS)	220 Ω 1/4W Res.
40	5	n/a	R308, R310, R315>R316, WX (R300, R307, R309, R311, R313>R314, WY: NS)	0 Ω Jumper Wire (24ga.)
41	1	121-5036-00	R312	330 Ω 1/4W Res.
42	16	121-5047-00	R401>R402, R403>R405, R406>R408, R423>R430	560 Ω 1/4W Res.
43	2	121-5048-00	R410, R411	3.3K Ω 1/4W Res.
44	1	n/a	SW200	B3F4000
45	1	181-5002-00	SW300	8-Pin, Dip Switch
46	5	100-0037-00	U1, U8, U25, U27, U215	74LS74
47	1	100-0249-00	U2	74HC4020
48	1	100-0049-00	U3	74LS163
49	1	105-0052-05	U4	6116 RAM
50	3	077-5208-00	U4, U7, U212	28-Pin, IC Dip Socket
51	6	100-0064-00	U5, U12, U13, U15, U16, U211	74LS374
52	1	100-0189-01	U6, U209	68B09E
53	3	077-5209-00	U6, U9, U209	40-Pin, IC Socket
54	1	(See Pg. DR. \bullet Table)	U7	27512 EPROM
55	1	105-0116-00	U9	BSMT2000
56	1	100-0149-00	U10	74LS240
57	5	(See Pg. DR. \bullet Table)	U17, U21, U36, U37, U210	27C040 EPROM
58	5	077-5217-00	U17, U21, U36, U37, U210	32-Pin, IC Socket
59	1	100-0043-00	U18	74ALS139
60	1	965-0136-00	U19 - YELLOW DOT	PAL16L8 (Programmed) YELLOW DOT
61	1	965-0137-00	U20 - WHITE DOT	PAL16L8 (Programmed) WHITE DOT
62	2	100-0022-00	U22, U11	74LS273
63	2	100-5008-00	U23, U24	74LS165
64	1	100-5018-00	U26	TDA1543
65	1	100-0375-00	U30	LM833
66	1	100-0027-00	U34	74LS04
67	0	100-5016-00	(U35: NS)	TDA1899
68	2	100-5016-20	U101, U102 (U100 : NS)	TDA2030A
69	3	535-5000-10	U101 (HS2), U102 (HS3) (U100 (HS1): NS)	AAVID 531102 (Heat Sink)
70	2	100-5012-00	U201, U203	74HCT273
71	6	100-0338-00	U202, U204, U205, U206, U207, U208 (U200: NS)	74HC245
72	1	105-5046-00	U212	MS6264A
73	1	965-6504-00	U213 - BLUE DOT	PAL16L8 (Programmed) BLUE DOT
74	1	100-0148-00	U214	74LS138
75	2	100-5015-00	U216, U217	HCT74
76	1	100-5023-00	U218	DS1232
77	2	100-0377-00	U400, U401	LM339AN
78	4	n/a	VBATT, +5v, GND1, GND2	Test Point Wire (24ga.) Loops
79	1	124-5002-00	VR1	LM7905CT -5v Regulator
80	1	124-5001-00	VR2	LM7805CT +5v Regulator
81	6	124-5064-00	W1, W5, W6* (*for 8MB EPROMs) (W2-W3, W4: NS)	0 Ω Jumper Wire (24ga.)
82	1	140-0011-00	X1	24Mhz
83	12	n/a	AOR, AOL, SND, RESET, SND, FIRQ, Q, E, 6Mhz, 24Mhz, FIRQ, PLASMA, RESET, RESET (X2)	Test Points
84	1	(call Tech. Support)	R110 (New Rev. Change Feb 02)	33K Ω 1/4W Res.



Color Dot Display (5X7) x4 PC Bd. (TV Set) Component Layout

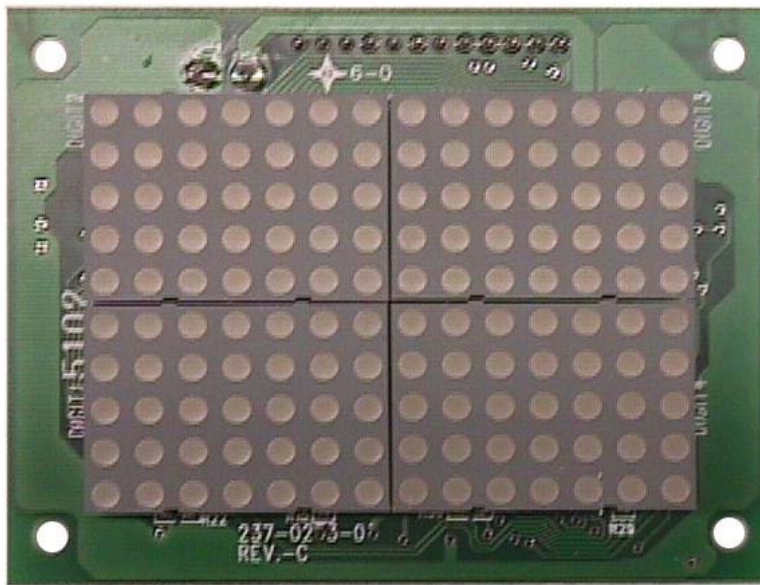
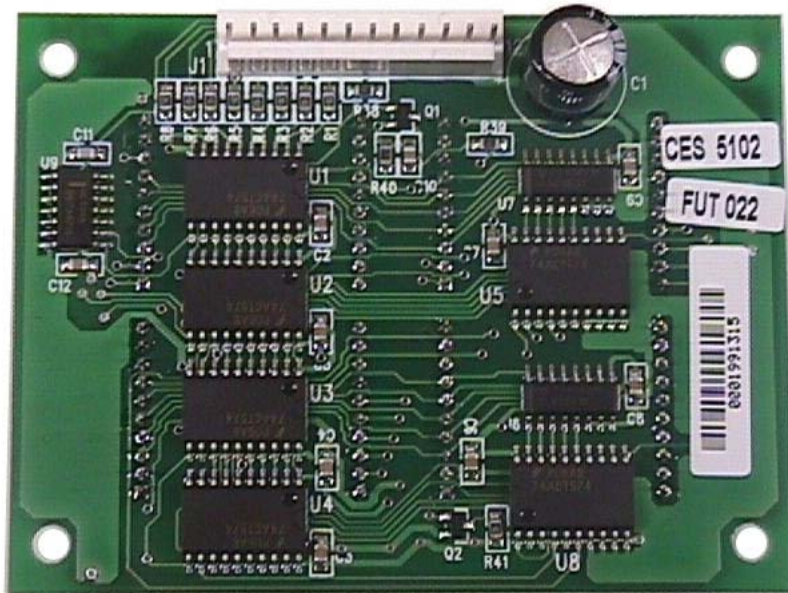

*This PCB is used in the TV Set on the 2nd Level Mini-Playfield.
See Section 4, Chapter 2, Page 96, for associated parts or better view.
If Schematic is required, call Technical Support at 1-800-542-5377 to ask for availability.*

Sec. 5: PCBs

ITEM	QTY	PART NUMBER	REF-DESIGNATOR	DESCRIPTION
--	1	520-5219-00	Color Dot Display (5X7) x4 PC Board	PCB Assembly

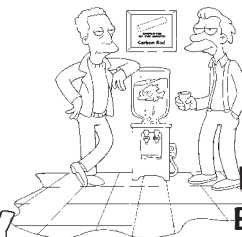

LED PC Board (Mode Signifier) Component Layout

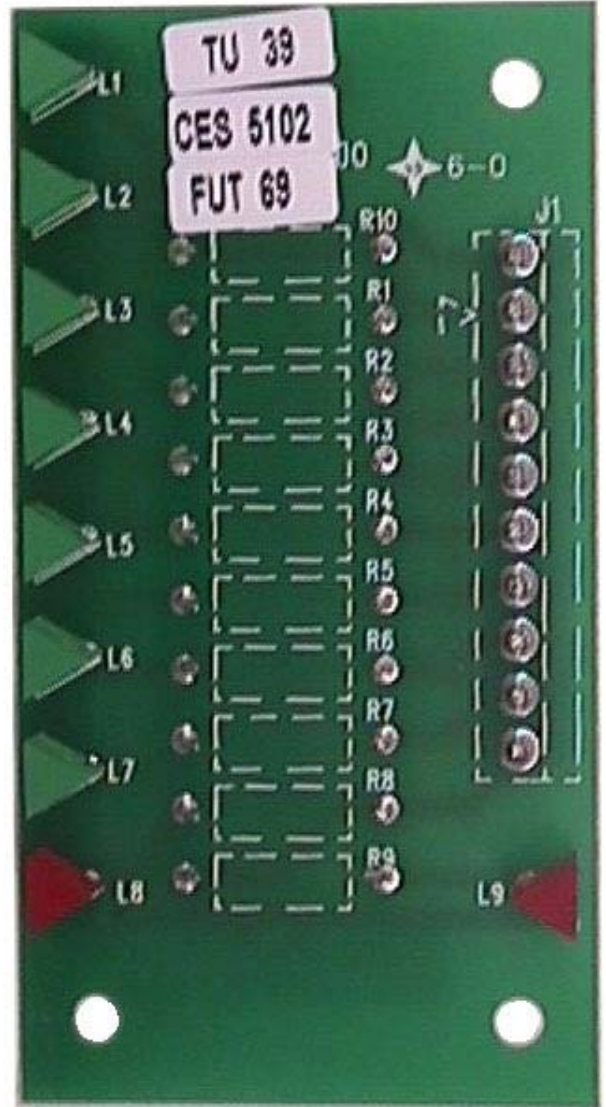
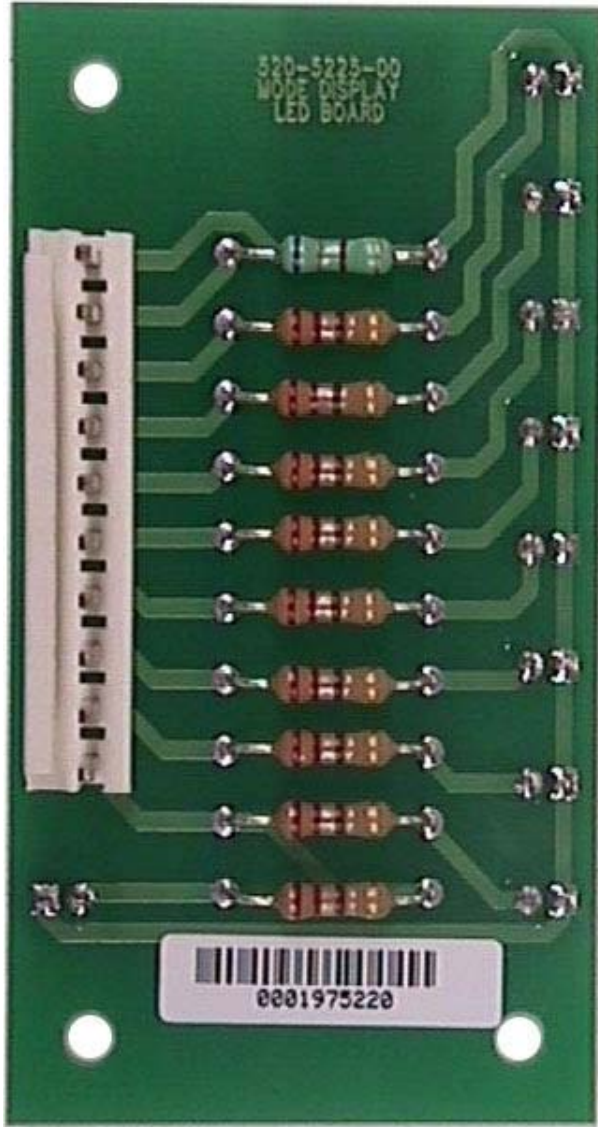

*This PCB is used on the Back Panel next to the TV Set.
See Section 4, Chapter 2, Page 96, for associated parts or better view.
If Schematic is required, call Technical Support at 1-800-542-5377 to ask for availability.*

ITEM	QTY	PART NUMBER	REF-DESIGNATOR	DESCRIPTION
--	1	520-5225-00	LED PC Board	PCB Assembly

Printed Circuit Boards (PCBs)



Section 5, Chapter 4
Page 141

Sec. 5: PCBs

Tournament Serial Interface Board Schematic (Sheet 1 of 1)

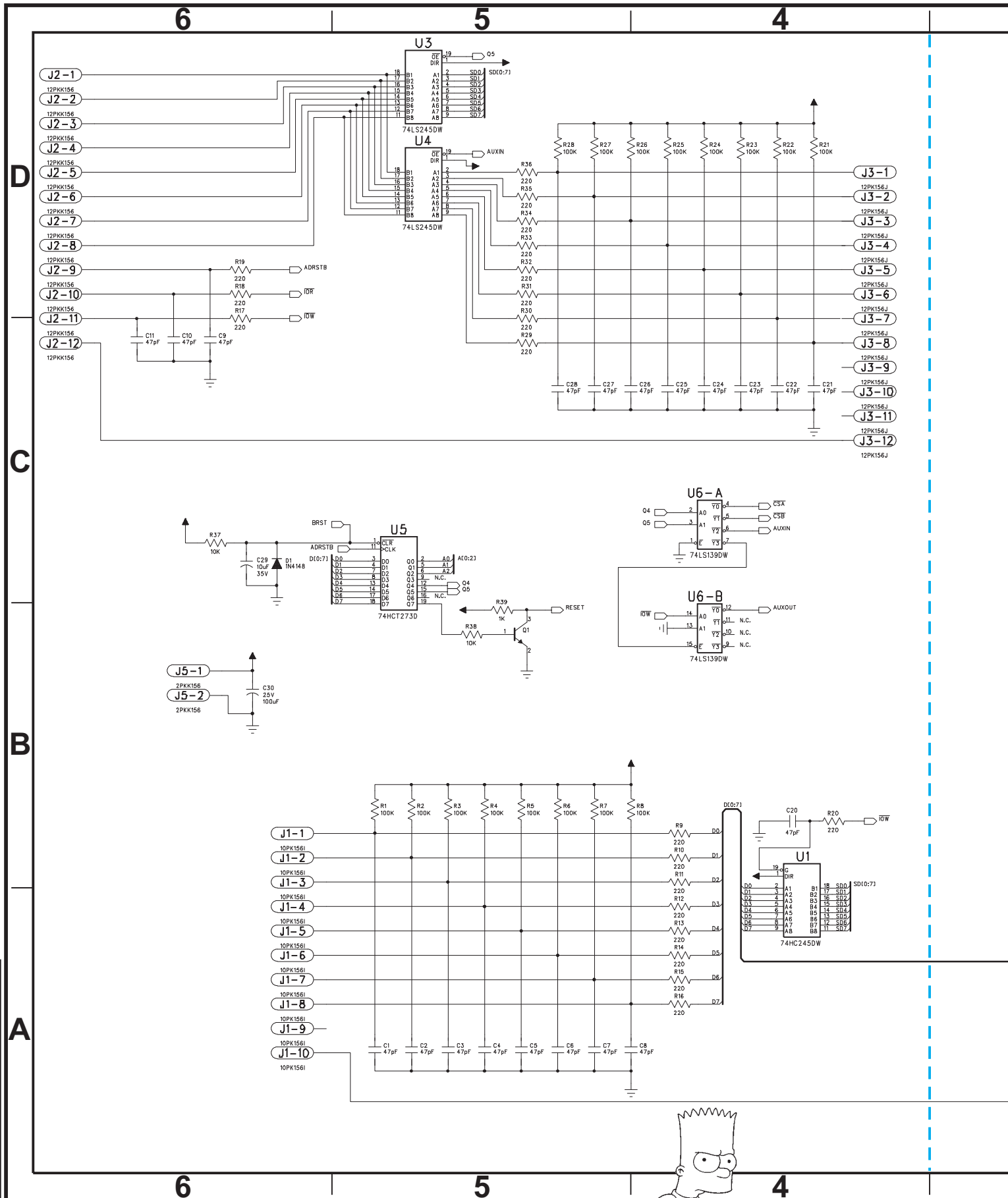

Sec. 5: PCBs

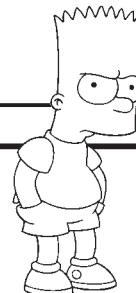

Tournament Serial Interface Board Schematic (Sheet 1 of 1)

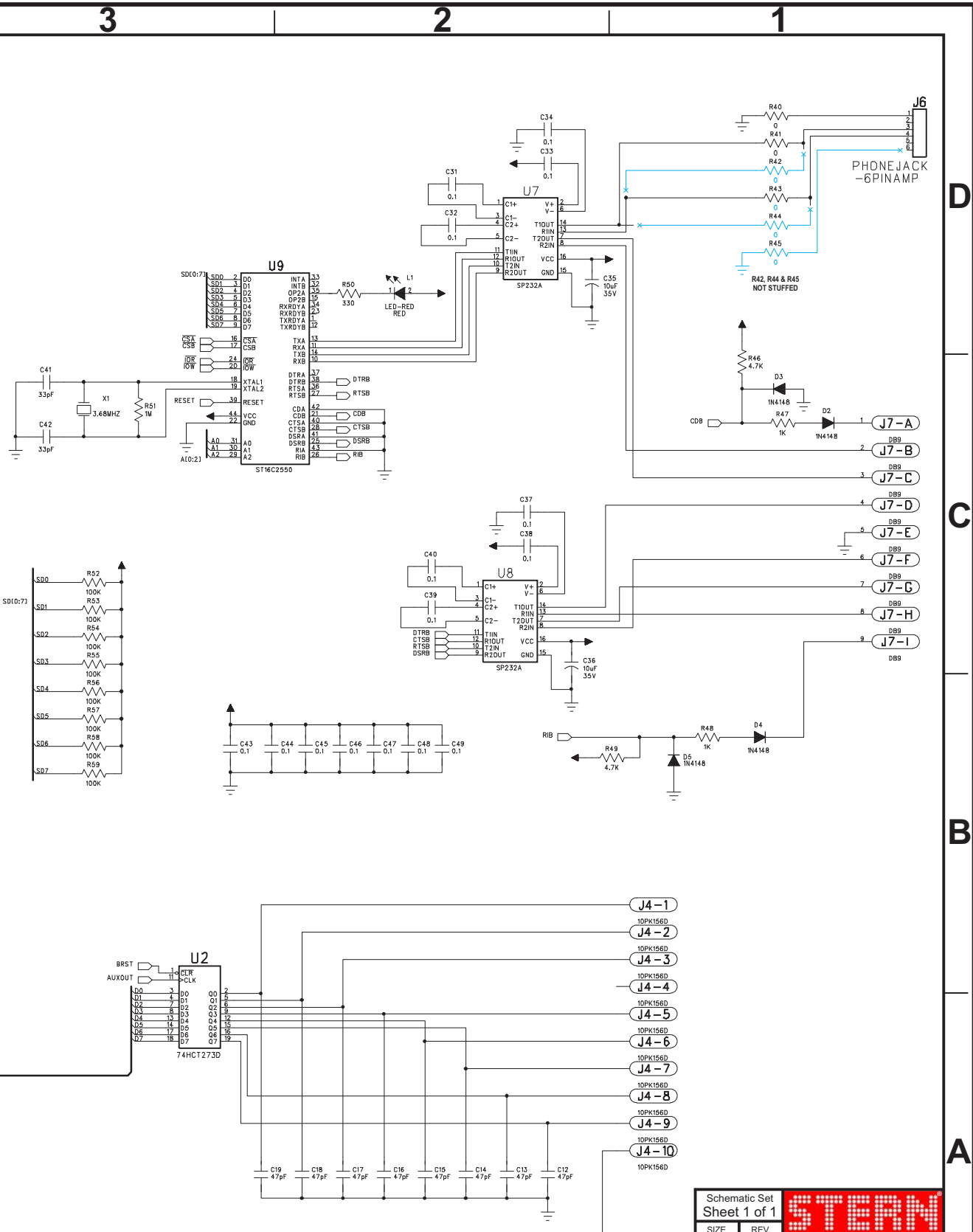

NOTES:
 ☑ ALL RESISTOR VALUES ARE IN OHMS (Ω), 1/4W, 5%, UNLESS OTHERWISE SPECIFIED.
 ☑ ALL CAPACITOR VALUES ARE IN MICROFARADS (μ F), UNLESS OTHERWISE SPECIFIED.
 ☑ 0.1 MICROFARADS (μ F) BYPASS CAPACITOR ON ALL IC'S.

Non-Text Document

Schematic Set Sheet 1 of 1		STERN PINBALL, INC.
SIZE D	REV. A	
SPI Tournament Serial Interface Bd. SPI Part No: 520-5220-00		
Prepared By: CES Inc. Edited By: SPI Inc. Model: 237-0268-00 Dated: 08/2002		

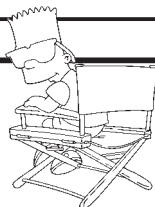

Sec. 5: PCBs

Tournament Serial Interface Board Component Layout

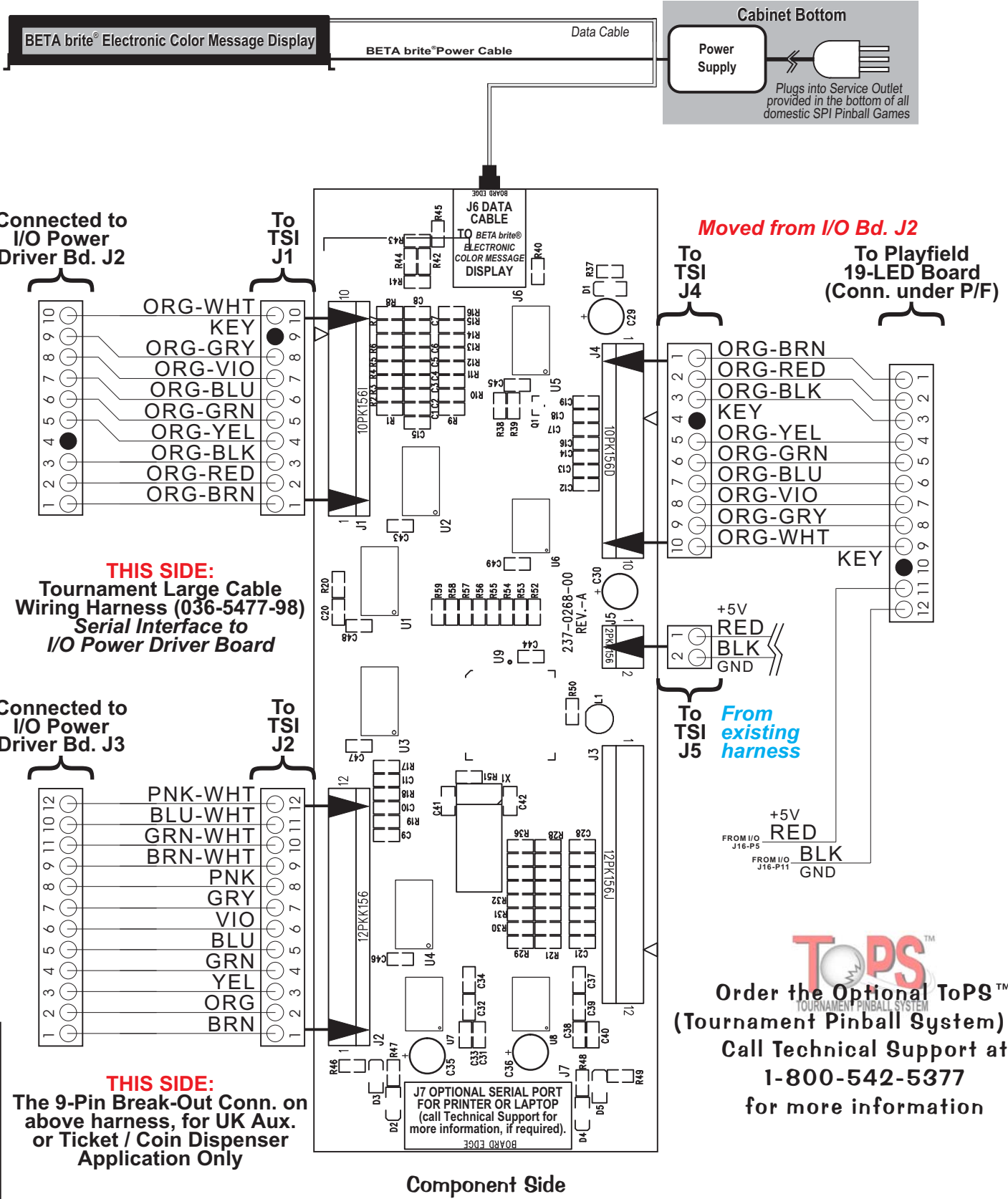

THIS SIDE:
The 9-Pin Break-Out Conn. on
above harness, for UK Aux.
or Ticket / Coin Dispenser
Application Only

TOPS™
Tournament Pinball System
Order the Optional ToPS™
(Tournament Pinball System) Kit!
Call Technical Support at
1-800-542-5377
for more information

Sec. 5: PCBs

ITEM	QTY	PART NUMBER	REF-DESIGNATOR	DESCRIPTION
--	1	520-5220-00	Tournament Serial Interface (TSI) Board	PCB Assembly



Appendixes A through J

Table of Contents for Appendixes

- **Appendix A : Pinball Game Firmware TableA1-A2**
 - ▶ [White Star Board System and S.A.M. System Only*]
 - ▷ ... describes the ROM / Chip Size / Program & Raw Part Number / USA Version / Check Sum and CPU/Sound PCB I & II ROM locations for Games Apollo 13 — Grand Prix (White Star Games); World Poker Tour – current (S.A.M. Games).
- **Appendix B : Semi-Conductors / I.C.'s / Relays Cross-Reference Table B1**
 - ▷ ...describes diodes and transistors with Source Number, SPI Part Number, NTE Number, ECG Number, Radio Shack Number & RCA Part Number (If applicable).
- **Appendix C : Production Start Date, Manual Part N^o, ROM Size & Positions and Jumper W6 .. C1**
 - ▶ [White Star Board System and S.A.M. System Only*]
 - ▷ ...provides the Production Start Date, Manual Part Number, ROM Position(s), and Jumpers Installed for Games Apollo 13 — Grand Prix (White Star Games); World Poker Tour – current (S.A.M. Games).
- **Appendix D : Board TyPe Table D1-D2**
 - ▶ [White Star Board System and S.A.M. System Only*]
 - ▷ ...provides the Flipper**, I/O Power Driver, CPU/Sound, Display Power Supply, Dot Matrix Display, Display Controller, OPTOs and Misc. Board Part Numbers for Games Apollo 13 — Grand Prix (White Star Games); World Poker Tour – current (S.A.M. Games). ***Flipper Bd. with White Star Bd. System for A13 & Golden Eye only.*
- **Appendix E : Generic Coil Cross-Reference Guide & Flipper Coil TableE1-E2**
 - ▶ [White Star Board System and S.A.M. System Only*]
 - ▷ ...provides the Coils used with Part Number and Gauge-Turns (of the coil) for Games Apollo 13 — Grand Prix (White Star Games); World Poker Tour – current (S.A.M. Games).
- **Appendix F : Motor Specification Table F1-F2**
 - ▶ [White Star Board System and S.A.M. System Only*]
 - ▷ ...provides all the Motor Function, Specifications and Part Number for Games Apollo 13 — Grand Prix (White Star Games); World Poker Tour – current (S.A.M. Games)..
- **Appendix G : Part Number Prefix Classification Codes G1**
 - ▷ ...explains how our Part Numbers are developed to help sort parts easier.
- **Appendix H : Playfield Inserts (Plastic Light Covers) H1**
 - ▷ ...gives a pictoral view with the name and Part Nr. of all the inserts used (with Color Code Chart).
- **Appendix I : Stand-Up Targets & Modular Stand-Up Targets I1-I2**
 - ▷ ...gives a pictoral view with the name and Part Number of all the Single Stand-Up Targets used (with Color Code Chart).
- **Appendix J : Coin Cards (USA & International) J1**
 - ▷ ...gives a pictoral view with the name and Part Number of all the current Coin Cards for USA, Canada, Euro and other International Countries. For all Coin Cards and/or free Coin Card files for download, visit our website : www.sternpinball.com



APPENDIX A



Pinball Game Firmware (White Star Board System* Only) Table

See website for the latest International Code or Updated USA version / checksums

ROM	Chip Size	Program Part N°	USA ver. & Check Sum	Bd. Loc.	Raw Part N°
Apollo 13 (Note 1)					
Game ROM (1M)	965-0208-00	A5.01	\$09FF	U210	960-5009-00
Sound (512K)	965-0212-00	1.00	\$5244	U7	960-7001-02
Display (4M)	965-0213-00	A5.00	\$B92B	ROM 0	960-5015-01
Voice 1 (4M)	965-0209-00	1.00	\$7FC7	U17	n/a (masked)
Voice 2 (4M)	965-0210-00	1.00	\$8E55	U21	n/a (masked)
Voice 3 (4M)	965-0211-00	1.00	\$08EE	U36	n/a (masked)
Golden Eye (Note 1)					
Game ROM (1M)	965-0214-42	A4.04	\$3FFF	U210	960-5009-00
Sound (512K)	965-0217-42	1.00	\$D615	U7	960-7001-02
Display (4M)	965-0218-42	A4.00	\$E6ED	ROM 0	960-5015-01
Voice 1 (4M)	965-0215-42	1.00	\$3E32	U17	n/a (masked)
Voice 2 (4M)	965-0216-42	1.00	\$71F0	U21	n/a (masked)
Twister (Note 2)					
Game ROM (1M)	965-0219-41	A4.05	\$E9FF	U210	960-5009-00
Sound (512K)	965-0221-41	1.00	\$1FFF	U7	960-7001-02
Display (4M)	965-0222-41	A4.00	\$FD01	ROM 0	960-5015-01
Voice 1 (4M)	965-0220-41	1.00	\$3650	U17	960-5015-01
Voice 2 (4M)	965-0223-41	1.00	\$9300	U21	960-5015-01
ID4: Independence Day (Note 2)					
Game ROM (1M)	965-0224-45	A2.02	\$9CFF	U210	960-5009-00
Sound (512K)	965-0227-45	1.00	\$222B	U7	960-7001-02
Display (4M)	965-0228-45	A2.00	\$AB7	ROM 0	960-5015-01
Voice 1 (4M)	965-0225-45	1.00	\$3AF1	U17	960-5015-01
Voice 2 (4M)	965-0226-45	1.00	\$206E	U21	960-5015-01
Space Jam (Note 2)					
Game ROM (1M)	965-0229-43	A3.00	\$E6FF	U210	960-5009-00
Sound (512K)	965-0233-43	1.00	\$F1E7	U7	960-7001-02
Display (4M)	965-0234-43	A3.00	\$0057	ROM 0	960-5015-01
Voice 1 (4M)	965-0230-43	1.00	\$DBA8	U17	960-5015-01
Voice 2 (4M)	965-0231-43	1.00	\$DDF1	U21	960-5015-01
Voice 3 (4M)	965-0232-43	1.00	\$F32A	U36	960-5015-01
The Star Wars Trilogy - Special Edition (S.E.) (Note 2)					
Game ROM (1M)	965-0235-56	A4.03	\$5EFF	U210	960-5009-00
Sound (512K)	965-0238-56	1.00	\$4A7D	U7	960-7001-02
Display (4M)	965-0239-56	A4.00	\$8817	ROM 0	960-5015-01
Voice 1 (4M)	965-0236-56	1.00	\$E66B	U17	960-5015-01
Voice 2 (4M)	965-0237-56	1.00	\$8F54	U21	960-5015-01
The Lost World: Jurassic Park (Note 2)					
Game ROM (1M)	965-0240-53	A2.02	\$C8FF	U210	960-5009-00
Sound (512K)	965-0243-53	1.00	\$A35B	U7	960-7001-02
Display (4M)	965-0244-53	A2.01	\$7F46	ROM 0	960-5015-01
Voice 1 (4M)	965-0241-53	1.00	\$1D27	U17	960-5015-01
Voice 2 (4M)	965-0242-53	1.00	\$8DA4	U21	960-5015-01
The X-Files (Note 2)					
Game ROM (1M)	965-0245-46	A3.03	\$A2FF	U210	960-5009-00
Sound (512K)	965-0248-46	1.00	\$65A8	U7	960-7001-02
Display (4M)	965-0249-46	A3.00	\$66D0	ROM 0	960-5015-01
Voice 1 (4M)	965-0246-46	1.00	\$349D	U17	960-5015-01
Voice 2 (4M)	965-0247-46	1.00	\$629C	U21	960-5015-01
Starship Troopers (Note 3)					
Game ROM (1M)	965-0250-59	A2.00	\$85FF	U210	960-5009-00
Sound (512K)	965-0253-59	1.00	\$64B2	U7	960-7001-02
Display (4M)	965-0254-59	A2.00	\$E77B	ROM 0	960-5015-01
Voice 1 (4M)	965-0251-59	1.00	\$152A	U17	960-5015-01
Voice 2 (4M)	965-0252-59	1.00	\$0291	U21	960-5015-01
Voice 3 (4M)	965-0255-59	1.00	\$95A7	U36	960-5015-01
Viper Night Drivin' (Note 4)					
Game ROM (1M)	965-0266-35	A2.01	\$C5FF	U210	960-5009-00
Sound (512K)	965-0271-35	1.00	\$4DF8	U7	960-7001-02
Display (4M)	965-0272-35	A2.01	\$C17D	ROM 0	960-5015-01
Voice 1 (4M)	965-0267-35	1.00	\$9018	U17	960-5015-01
Voice 2 (4M)	965-0268-35	1.00	\$2157	U21	960-5015-01
Voice 3 (4M)	965-0269-35	1.00	\$B5A6	U36	960-5015-01
Voice 4 (4M)	965-0270-35	1.00	\$D01E	U37	960-5015-01
Lost In Space (Note 4)					
Game ROM (1M)	965-0282-60	A1.01	\$B2FF	U210	960-5009-00
Sound (512K)	965-0287-60	1.00	\$A6AF	U7	960-7001-02
Display (4M)	965-0288-60	A1.02	\$32AB	ROM 0	960-5015-01
Voice 1 (4M)	965-0283-60	1.00	\$4391	U17	960-5015-01
Voice 2 (4M)	965-0284-60	1.00	\$8215	U21	960-5015-01
Voice 3 (4M)	965-0285-60	1.00	\$5B32	U36	960-5015-01
Voice 4 (4M)	965-0286-60	1.00	\$8971	U37	960-5015-01
Godzilla (Note 4)					
Game ROM (1M)	965-0289-40	A2.05	\$B1FF	U210	960-5009-00
Sound (512K)	965-0294-40	1.00	\$0CC9	U7	960-7001-02
Display (4M)	965-0295-40	A2.00	\$C929	ROM 0	960-5015-01
Voice 1 (4M)	965-0290-40	1.00	\$0D75	U17	960-5015-01
Voice 2 (4M)	965-0291-40	1.00	\$CCCF	U21	960-5015-01
Voice 3 (4M)	965-0292-40	1.00	\$227F	U36	960-5015-01
Voice 4 (4M)	965-0293-40	1.00	\$DB69	U37	960-5015-01
South Park (Notes 4, 5)					
Game ROM (1M)	965-0301-71	A1.03	\$58FF	U210	960-5009-00
Sound (512K)	965-0306-71	1.00	\$1286	U7	960-7001-02
Display (4M)	965-0307-71	A1.01	\$166F	ROM 0	960-5015-01
Voice 1 (8M)	965-0302-71	1.00	\$7BF8	U17	960-5016-00
Voice 2 (8M)	965-0303-71	1.00	\$9CC0	U21	960-5016-00
Voice 3 (8M)	965-0304-71	1.00	\$ADD9	U36	960-5016-00
Voice 4 (8M)	965-0305-71	1.00	\$6559	U37	960-5016-00

ROM	Chip Size	Program Part N°	USA Ver. & Check Sum	Bd. Loc.	Raw Part N°
Harley-Davidson® (Notes 4, 5, 6) Original (1999-2001)					
Game ROM (1M)	965-0319-67	A1.03	\$3EFF	U210	960-5009-00
Sound (512K)	965-0320-67	1.00	\$F4FF	U7	960-7001-02
Display (4M)	965-0321-67	A1.04	\$FC7C	ROM 0	960-5015-01
Voice 1 (8M)	965-0322-67	1.00	\$CD26	U17	960-5016-00
Voice 2 (8M)	965-0323-67	1.00	\$3936	U21	960-5016-00
Voice 3 (8M)	965-0324-67	1.00	\$FB72	U36	960-5016-00
Voice 4 (4M)	965-0325-67	1.00	\$6100	U37	960-5015-01
► Harley-Davidson® (Notes 4, 5, 6, 8) 2nd Edition (2002-2003)					
Game ROM (1M)	965-0319-67A	A1.08	\$23FF	U210	960-5009-00
Display (4M)	965-0321-67A	A1.05	\$B594	ROM 0	960-5015-01
► Harley-Davidson® (Notes 4, 5, 6, 8) 3rd Edition (2004)					
Game ROM (1M)	965-0319-87	A4.00	\$1CFF	U210	960-5009-00
Display (4M)	965-0321-87	A4.00	\$F4FF	U5	960-5015-01
Striker Xtreme (Notes 4, 5)					
Game ROM (1M)	965-0326-68	A1.03	\$E4FF	U210	960-5009-00
Sound (512K)	965-0327-68	1.00	\$3BCA	U7	960-7001-02
Display (4M)	965-0328-68	A1.03	\$1957	ROM 0	960-5015-01
Voice 1 (8M)	965-0329-68	1.00	\$482A	U17	960-5016-00
Voice 2 (8M)	965-0330-68	1.00	\$7312	U21	960-5016-00
Voice 3 (8M)	965-0331-68	1.00	\$DE2F	U36	960-5016-00
Voice 4 (8M)	965-0332-68	1.00	\$C508	U37	960-5016-00
NFL (Notes 4, 5) Not on CD-R or Website: Code through Distributor Only.					
Game ROM (1M)	965-0339-73	A1.00	\$D2FF	U210	960-5009-00
Sound (512K)	965-0340-73	1.00	U7	960-7001-02	
Display (4M)	965-0341-73	A1.01	\$845A	ROM 0	960-5015-01
Voice 1 (8M)	965-0342-73	1.00	U17	960-5016-00	
Voice 2 (8M)	965-0343-73	1.00	U21	960-5016-00	
Voice 3 (8M)	965-0344-73	1.00	U36	960-5016-00	
Voice 4 (8M)	965-0345-73	1.00	U37	960-5016-00	
Sharkey's Shootout (Notes 4, 5)					
Game ROM (1M)	965-0333-72	A2.11	\$49FF	U210	960-5009-00
Sound (512K)	965-0333-72	1.01	\$9796	U7	960-7001-02
Display (4M)	965-0335-72	A2.01	\$6C33	ROM 0	960-5015-01
Voice 1 (8M)	965-0336-72	1.00	\$58EA	U17	960-5016-00
Voice 2 (8M)	965-0337-72	1.00	\$272B	U21	960-5016-00
Voice 3 (8M)	965-0338-72	1.00	\$41AE	U36	960-5016-00
High Roller Casino (Notes 4, 5)					
Game ROM (1M)	965-0346-65	A3.00	\$90FF	U210	960-5009-00
Sound (512K)	965-0347-65	1.00	\$581C	U7	960-7001-02
Display (4M)	965-0348-65	A3.00	\$74B3	ROM 0	960-5015-01
Voice 1 (8M)	965-0349-65	1.00	\$E12D	U17	960-5016-00
Voice 2 (8M)	965-0350-65	1.00	\$38F4	U21	960-5016-00
Voice 3 (8M)	965-0351-65	1.00	\$1B54	U36	960-5016-00
Voice 4 (8M)	965-0352-65	1.00	\$D720	U37	960-5016-00
Austin Powers™ (Notes 4, 5)					
Game ROM (1M)	965-0353-74	A3.02	\$5DFF	U210	960-5009-00
Sound (512K)	965-0354-74	1.00	\$D47B	U7	960-7001-02
Display (4M)	965-0355-74	A3.00	\$6A3A	ROM 0	960-5015-01
Voice 1 (8M)	965-0356-74	1.00	\$D2B9	U17	960-5016-00
Voice 2 (8M)	965-0357-74	1.00	\$9E75	U21	960-5016-00
Voice 3 (8M)	965-0358-74	1.00	\$51F3	U36	960-5016-00
Voice 4 (8M)	965-0359-74	1.00	\$0AE5	U37	960-5016-00
MONOPOLY® (Notes 4, 5)					
Game ROM (1M)	965-0360-75	A3.20	\$07FF	U210	960-5009-00
Sound (512K)	965-0361-75	1.00	\$8C18	U7	960-7001-02
Display (4M)	965-0362-75	A3.01	\$A381	ROM 0	960-5015-01
Voice 1 (8M)	965-0363-75	1.00	\$35E6	U17	960-5016-00
Voice 2 (8M)	965-0364-75	1.00	\$B35A	U21	960-5016-00
Voice 3 (8M)	965-0365-75	1.00	\$8A9F	U36	960-5016-00
Playboy (Notes 4, 5, 7)					
Game ROM (1M)	965-0367-76	A5.00	\$7DFF	U210	960-5009-00
Sound (512K)	965-0368-76	1.02	\$E7C2	U7	960-7001-02
Display (4M)	965-0369-76	A5.00	\$A5FF	ROM 0	960-5015-01
Voice 1 (8M)	965-0370-76	1.00	\$9A9E	U17	960-5016-00
Voice 2 (8M)	965-0371-76	1.00	\$9F34	U21	960-5016-00
Voice 3 (8M)	965-0372-76	1.00	\$374B	U36	960-5016-00
Voice 4 (8M)	965-0373-76	1.00	\$237A	U37	960-5016-00
RollerCoaster Tycoon™ (Notes 4, 5, 7)					
Sound (512K)	965-0374-78	1.00	\$F663	U7	960-7001-02
Game ROM (1M)	965-0375-78	A7.02	\$E5FF	U210	960-5009-00
Voice 1 (8M)	965-0377-78	1.00	\$3C4A	U17	960-5016-00
Voice 2 (8M)	965-0378-78	1.00	\$057A	U21	960-5016-00
Voice 3 (8M)	965-0379-78	1.00	\$04D7		



APPENDIX A

Pinball Game Firmware (White Star Board System* & S.A.M. System** Only) Table

See website for the latest International Code or Updated USA version / checksums

ROM	Chip Size	Program Part N ^o	USA Ver. & Check Sum	Bd. Loc.	Raw Part N ^o
Ripley's Believe It or Not!® (Notes 7, 8)					
Sound	(512K)	965-0408-81	1.00 \$D93D	U7	960-7001-02
Game ROM	(1M)	965-0409-81	A3.20 \$43FF	U210	960-5009-00
Voice 1	(8M)	965-0410-81	1.00	\$067B U17	960-5016-00
Voice 2	(8M)	965-0411-81	1.00	\$C8B8 U21	960-5016-00
Voice 3	(8M)	965-0412-81	1.00	\$64C2 U36	960-5016-00
Voice 4	(8M)	965-0413-81	1.00	\$5341 U37	960-5016-00
Display	(4M)	965-0414-81	A3.00 \$DE4B	U5 DC PCB	960-5015-01

Elvis® (Notes 7, 8)					
Sound	(512K)	965-0415-84	1.00 \$8CD2	U7	960-7001-02
Game ROM	(1M)	965-0416-84	A5.00 \$50FF	U210	960-5009-00
Voice 1	(8M)	965-0417-84	1.00	\$538D U17	960-5016-00
Voice 2	(8M)	965-0418-84	1.00	\$8BCD U21	960-5016-00
Voice 3	(8M)	965-0419-84	1.00	\$60F8 U36	960-5016-00
Voice 4	(8M)	965-0420-84	1.00	\$14D8 U37	960-5016-00
Display	(4M)	965-0421-84	A5.00 \$A1F6	U5 DC PCB	960-5015-01

The SopranosSM (Notes 7, 8)					
Sound	(512K)	965-0422-85	4.00 \$9B5A	U7	960-7001-02
Game ROM	(1M)	965-0423-85	A5.00 \$5BFF	U210	960-5009-00
Voice 1	(8M)	965-0424-85	3.00	\$F01E U17	960-5016-00
Voice 2	(8M)	965-0425-85	1.04	\$C14C U21	960-5016-00
Voice 3	(8M)	965-0426-85	1.04	\$47A3 U36	960-5016-00
Voice 4	(8M)	965-0427-85	1.04	\$ADCD U37	960-5016-00
Display	(4M)	965-0428-85	A5.00 \$B4BB	U5 DC PCB	960-5015-01

NASCAR® (Notes 7, 8)					
Sound	(512K)	965-0429-86	2.00 \$32B3	U7	960-7001-02
Game ROM	(1M)	965-0430-86	A4.50 \$39FF	U210	960-5009-00
Voice 1	(8M)	965-0431-86	2.00	\$CFFB U17	960-5016-00
Voice 2	(8M)	965-0432-86	2.00	\$22C0 U21	960-5016-00
Voice 3	(8M)	965-0433-86	2.00	\$5FC8 U36	960-5016-00
Voice 4	(8M)	965-0434-86	2.00	\$2902 U37	960-5016-00
Display	(4M)	965-0435-86	A4.00 \$92BD	U5 DC PCB	960-5015-01

Grand Prix (Notes 7, 8)					
Sound	(512K)	965-0429-91	V1.00 \$6F89	U7	960-7001-02
Game ROM	(1M)	965-0430-91	A4.50 \$5EFF	U210	960-5009-00
Voice 1	(8M)	965-0431-91	1.00	\$C0E5 U17	960-5016-00
Voice 2	(8M)	965-0432-91	1.00	\$F4C6 U21	960-5016-00
Voice 3	(8M)	965-0433-91	1.00	\$057D U36	960-5016-00
Voice 4	(8M)	965-0434-91	1.00	\$2646 U37	960-5016-00
Display	(4M)	965-0435-91	A4.00 \$DA8E	U5 DC PCB	960-5015-01

[NDSE] (Notes 7, 8) <i>Call for more info if code update required.</i>					
Sound	(512K)	965-0436-97		U7	960-7001-02
Game ROM	(1M)	965-0437-97		U210	960-5009-00
Voice 1	(8M)	965-0438-97		U17	960-5016-00
Voice 2	(8M)	965-0439-97		U21	960-5016-00
Voice 3	(8M)	965-0440-97		U36	960-5016-00
Voice 4	(8M)	965-0441-97		U37	960-5016-00
Display	(4M)	965-0442-97		U5 DC PCB	960-5015-01

**** GAMES BELOW THIS LINE / NEXT COLUMN ARE S.A.M. SYSTEM GAMES**

TO ORDER MEMORY STICK WITH GAME FILES FROM YOUR DISTRIBUTOR, USE SPI PART NUMBER 970-0128-00 & INCLUDE THE GAME NAME / LANGUAGE FILE(S) DESIRED.

World Poker Tour™ Pinball (WPT) (Notes 7, 9)					
Boot B-02	(8M)	965-BOOT-SAM	1.04 \$7E62	U9	960-5016-00 unprogrammed
Memory Stick 128MB (970-0128-00)		Version		System	Bin Files:
English + Spanish		1.12AL		1.17+	WPT0112AL.bin
English Only		1.12A		1.17+	WPT0112A.bin
English + French		1.12AF		1.17+	WPT0112AF.bin
French Only		1.12F		1.17+	WPT0112F.bin
German + French		1.12GF		1.17+	WPT0112GF.bin
German Only		1.12G		1.17+	WPT0112G.bin
English + Italian		1.12AI		1.17+	WPT0112AI.bin
Italian Only		1.12I		1.17+	WPT0112I.bin

NOTE: THE TYPICAL SIZE PER UNZIPPED BIN FILE IS 25MB – 30MB+/-

The Simpsons™ Kooky Carnival Redemption (Note 9)					
Boot B-02	(8M)	965-BOOT-SAM	1.04 \$7E62	U9	960-5016-00 unprogrammed
Memory Stick 128MB (970-0128-00)		Version		Bin Files:	
English Only		1.05		SKC0105.bin	
English New Jersey Only		0.09NJ		SKC0090NJ.bin	

NOTE: THE TYPICAL SIZE PER UNZIPPED BIN FILE IS 5.5MB +/-

©Disney's Pirates of the Caribbean Pinball (POTC) (Notes 7, 9)					
Boot B-02	(8M)	965-BOOT-SAM	1.06 \$2014	U9	960-5016-00 unprogrammed
Memory Stick 128MB (970-0128-00)		Version		System	Bin Files:
English + Spanish		1.15AS		1.17+	POTC115AS.bin
English + French		1.15AF		1.17+	POTC115AF.bin
German + French		1.15GF		1.17+	POTC115GF.bin
English + Italian		1.15AI		1.17+	POTC115AI.bin

NOTE: THE TYPICAL SIZE PER UNZIPPED BIN FILE IS 25MB – 30MB+/-

Family Guy™ Pinball (FG) (Notes 7, 9)					
Boot B-02	(8M)	965-BOOT-SAM	2.09 \$10A3	U9	960-5016-00 unprogrammed
Memory Stick 128MB (970-0128-00)		Version		System	Bin Files:
English + Spanish		10.00AL		1.23+	FG1000AL.bin
English + French		10.00AF		1.23+	FG1000AF.bin
English + German		10.00AG		1.23+	FG1000GF.bin
English + Italian		10.00AI		1.23+	FG1000AI.bin

NOTE: THE TYPICAL SIZE PER UNZIPPED BIN FILE IS 25MB – 30MB+/-

Spider-Man™ Pinball (S-M) (Notes 7, 9)					
Boot B-02	(8M)	965-BOOT-SAM	2.10 \$F625	U9	960-5016-00 unprogrammed
Memory Stick 128MB (970-0128-00)		Version		System	Bin Files:
English + Spanish		1.3ES		1.27+	spd_1_30_es.bin
English + French		1.3EF		1.27+	spd_1_30_ef.bin
German + French		1.3GF		1.27+	spd_1_30_gf.bin
English + Italian		1.3EI		1.27+	spd_1_30_ei.bin

NOTE: THE TYPICAL SIZE PER UNZIPPED BIN FILE IS 25MB – 30MB+/-

footnotes:

- 1 ROMs on CPU/Sound Bd.: 520-5136-00 (Stereo) & Display Cont. Bd.: 520-5055-01
- 2 ROMs on CPU/Sound Bd.: 520-5136-10 (Mono) & Display Cont. Bd.: 520-5055-01
- 3 ROMs on CPU/Sound Board: 520-5136-15* (Mono) (*FCC 11-97) & Display Controller Board: 520-5055-02* (*FCC 11-97)



APPENDIX A

Pinball Game Firmware Table

EPROM	Chip Size	Program Part N ^o	USA Ver.	Bd. Loc.	Raw Part N ^o	EPROM	Chip Size	Program Part N ^o	USA Ver.	Bd. Loc.	Raw Part N ^o
Laser War						Lethal Weapon 3					
CPU	(256K)	965-0004-00	LWAR.C5	C5	960-5007-00	CPU	(512K)	965-0082-00	A2.08	C5	960-7001-02
Sound (old)	(256K)	965-0005-00		J5	960-5007-00	Voice 1	(2M)	965-0083-00		U17	960-5010-00
Sound (old)	(256K)	965-0006-00		J6	960-5007-00	Voice 2	(2M)	965-0084-00		U21	960-5010-00
Sound (old)	(256K)	965-0007-00		J7	960-5007-00	Sound	(256K)	965-0085-00		U7	960-5007-00
			- OR -			Display	(2M)	965-0086-00	A2.06	ROM 0	960-5010-00
Sound	(256K)	965-0008-00		7F	960-5007-00	Display	(2M)	965-0087-00	A2.06	ROM 1	960-5010-00
Sound 1	(512K)	965-0009-00		6F	960-7001-02			(Used on Display PCB 520-5055-00)			
Sound 2	(512K)	965-0010-00		4F	960-7001-02	Display	(4M)	965-0087-04	-OR- A2.06	ROM 0	960-5015-00
								(Used on Display PCB 520-5055-01)			
Secret Service						Star Wars					
CPU	(256K)	965-0011-00	A4-6	B5	960-5007-00	CPU	(512K)	965-0119-00	A1.03	C5	960-7001-02
CPU	(256K)	965-0012-00	A4-6	C5	960-5007-00	Voice 0	(4M)	965-0132-00		U17	960-5015-00
Voice 1	(512K)	965-0014-00		6F	960-7001-02	Voice 1	(2M)	965-0133-00		U21	960-5010-00
Voice 2	(512K)	965-0015-00		4F	960-7001-02	Sound	(256K)	965-0131-00		U7	960-5007-00
Sound	(256K)	965-0013-00		7F	960-5007-00	Display	(2M)	965-0120-00	A1.04	ROM 0	960-5010-00
						Display	(2M)	965-0121-00	A1.04	ROM 1	960-5010-00
								(Used on Display PCB 520-5055-00)			
Torpedo Alley						Rocky & Bullwinkle & Friends					
CPU	(256K)	965-0016-00	A2-1	B5	960-5007-00	CPU	(512K)	965-0138-00	A1.30	C5	960-7001-02
CPU	(256K)	965-0017-00	A2-1	C5	960-5007-00	Voice 0	(4M)	965-0139-00		U17	960-5015-00
Voice 1	(512K)	965-0018-00		6F	960-7001-02	Voice 1	(2M)	965-0140-00		U21	960-5010-00
Voice 2	(512K)	965-0019-00		4F	960-7001-02	Sound	(256K)	965-0141-00		U7	960-5007-00
Sound	(256K)	965-0018-00		7F	960-5007-00	Display	(4M)	965-0142-00	A1.30	ROM 0	960-5015-00
								(Used on Display PCB 520-5055-01)			
Time Machine						Jurassic Park					
CPU	(128K)	965-0021-00	A2-4	B5	960-5006-00	CPU	(512K)	965-0143-00	A5.13	C5	960-7001-02
CPU	(256K)	965-0022-00	A2-4	C5	960-5007-00	Voice 0	(4M)	965-0144-00		U17	960-5015-00
Voice 1	(512K)	965-0024-00		6F	960-7001-02	Voice 1	(2M)	965-0145-00		U21	960-5010-00
Voice 2	(512K)	965-0025-00		4F	960-7001-02	Sound	(256K)	965-0146-00		U7	960-5007-00
Sound	(256K)	965-0023-00		7F	960-5007-00	Display	(4M)	965-0147-00	A5.10	ROM 0	960-5015-00
Playboy 35th Anniversary						Last Action Hero					
CPU	(256K)	965-0046-00	A2-4	B5	960-5007-00	CPU	(512K)	965-0148-00	A1.12	C5	960-7001-02
CPU	(256K)	965-0047-00	A2-4	C5	960-5007-00	Voice 0	(4M)	965-0149-00		U17	960-5015-00
Voice 1	(512K)	965-0049-00		6F	960-7001-02	Voice 1	(2M)	965-0150-00		U21	960-5010-00
Voice 2	(512K)	965-0050-00		4F	960-7001-02	Sound	(256K)	965-0151-00		U7	960-5007-00
Sound	(256K)	965-0048-00		7F	960-5007-00	Display	(4M)	965-0152-00	A1.06	ROM 0	960-5015-00
ABC Monday Night Football						Tales from the Crypt					
CPU	(128K)	965-0031-00	A2-7	B5	960-5006-00	CPU	(512K)	965-0157-00	A3.03	C5	960-7001-02
CPU	(256K)	965-0032-00	A2-7	C5	960-5007-00	Voice 0	(4M)	965-0158-00		U17	960-5015-00
Voice 1	(512K)	965-0034-00		6F	960-7001-02	Voice 1	(2M)	965-0159-00		U21	960-5010-00
Voice 2	(512K)	965-0035-00		4F	960-7001-02	Sound	(256K)	965-0160-00		U7	960-5007-00
Sound	(256K)	965-0033-00		7F	960-5007-00	Display	(4M)	965-0161-00	A3.01	ROM 0	960-5015-00
Robocop						The Who's Tommy					
CPU	(256K)	965-0036-00	A3-4	B5	960-5007-00	CPU	(512K)	965-0162-00	A4.00	C5	960-7001-02
CPU	(256K)	965-0037-00	A3-4	C5	960-5007-00	Voice 1	(4M)	965-0163-00		U17	960-5015-00
Voice 1	(512K)	965-0039-00		6F	960-7001-02	Voice 2	(4M)	965-0166-00		U21	960-5010-00
Voice 2	(512K)	965-0040-00		4F	960-7001-02	Voice 3	(4M)	965-0167-00		U36	960-5015-00
Sound	(256K)	965-0038-00		7F	960-5007-00	Voice 4	(4M)	965-0168-00		U37	960-5015-00
						Sound	(512K)	965-0164-00		U7	960-7001-02
						Display	(4M)	965-0163-00	A4.00	ROM 0	960-5015-00
Phantom of the Opera						WWF Royal Rumble					
CPU	(128K)	965-0026-00	A3-2	B5	960-5006-00	CPU	(512K)	965-0169-00	A1.06	C5	960-7001-02
CPU	(256K)	965-0027-00	A3-2	C5	960-5007-00	Voice 1	(4M)	965-0172-00		U17	960-5015-00
Voice 1	(512K)	965-0029-00		6F	960-7001-02	Voice 2	(4M)	965-0173-00		U21	960-5010-00
Voice 2	(512K)	965-0030-00		4F	960-7001-02	Voice 3	(4M)	965-0174-00		U36	960-5015-00
Sound	(256K)	965-0028-00		7F	960-5007-00	Sound	(512K)	965-0171-00		U7	960-7001-02
						Display	(4M)	965-0170-00	A1.02	ROM 0	960-5015-00
Back to the Future						Guns N' Roses					
CPU	(256K)	965-0041-00	A2-0	B5	960-5007-00	CPU	(512K)	965-0175-00	A3.00	C5	960-7001-02
CPU	(256K)	965-0042-00	A2-0	C5	960-5007-00	Voice 1	(4M)	965-0178-00		U17	960-5015-00
Voice 1	(512K)	965-0044-00		6F	960-7001-02	Voice 2	(4M)	965-0179-00		U21	960-5010-00
Voice 2	(512K)	965-0045-00		4F	960-7001-02	Voice 3	(4M)	965-0180-00		U36	960-5015-00
Sound	(256K)	965-0043-00		7F	960-5007-00	Voice 4	(4M)	965-0181-00		U37	960-5015-00
						Sound	(512K)	965-0177-00		U7	960-7001-02
						Display	(4M)	965-0176-00	A3.00	ROM 0	960-5015-00
The Simpsons						Maverick *					
CPU	(128K)	965-0051-00	A2-7	B5	960-5006-00	CPU	(512K)	965-0182-00	A4.04	C5	960-7001-02
CPU	(256K)	965-0052-00	A2-7	C5	960-5007-00	Voice 1	(4M)	965-0186-00		U17	960-5015-00
Voice 1	(512K)	965-0054-00		6F	960-7001-02	Voice 2	(4M)	965-0187-00		U21	960-5010-00
Voice 2	(512K)	965-0055-00		4F	960-7001-02	Voice 3	(4M)	965-0187-01		U36	960-5015-00
Sound	(256K)	965-0053-00		7F	960-5007-00	Sound	(512K)	965-0185-00		U7	960-7001-02
						Display*	(4M)	965-0183-00	A4.01	ROM 0	960-5015-00
						Display*	(4M)	965-0184-00	A4.01	ROM 3	960-5015-00
Checkpoint						Mary Shelley's Frankenstein *					
CPU	(128K)	965-0056-00	A1-7	B5	960-5006-00	CPU	(512K)	965-0188-00	A1.03	C5	960-7001-02
CPU	(256K)	965-0134-00	A1-7	C5	960-5007-00	Voice 1	(4M)	965-0192-00		U17	960-5015-00
Voice 1	(1M)	965-0057-00		F7	960-5009-00	Voice 2	(4M)	965-0193-00		U21	960-5010-00
Voice 2	(1M)	965-0058-00		F5	960-5009-00	Voice 3	(4M)	965-0194-00		U36	960-5015-00
Sound	(256K)	965-0059-00		F4	960-5007-00	Sound	(512K)	965-0191-00		U7	960-7001-02
Display	(512K)	965-0060-00	CP80	U8	960-7001-02	Display*	(4M)	965-0189-00	A1.03	ROM 0	960-5015-00
						Display*	(4M)	965-0190-00	A1.03	ROM 3	960-5015-00
Teenage Mutant Ninja Turtles						Baywatch *					
CPU	(128K)	965-0061-00	A1.04	B5	960-5006-00	CPU	(512K)	965-0195-00	A4.00	C5	960-7001-02
CPU	(256K)	965-0062-00	A1.04	C5	960-5007-00	Voice 1	(4M)	965-0196-00		U17	960-5015-00
Voice 1	(1M)	965-0063-00		F5/6	960-5009-00	Voice 2	(4M)	965-0197-00		U21	960-5010-00
Voice 2	(1M)	965-0064-00		F4/5	960-5009-00	Sound	(512K)	965-0199-00		U7	960-7001-02
Sound	(256K)	965-0065-00		F7	960-5007-00	Display*	(4M)	965-0200-00	A4.00	ROM 0	960-5015-00
Display	(512K)	965-0066-00	A1.04	U8	960-7001-02	Display*	(4M)	965-0201-00	A4.00	ROM 3	960-5015-00
Batman						Batman Forever *					
CPU	(128K)	965-0067-00	A1.06	B5	960-5006-00	CPU	(512K)	965-0202-00	C5	C5	960-7001-02
CPU	(256K)	965-0135-00	A1.06	C5	960-5007-00	Voice 1	(4M)	965-0203-00	A3.02	U17	960-5015-00
Voice 1	(2M)	965-0068-00		U17	960-5010-00	Voice 2	(4M)	965-0204-00		U21	960-5010-00
Voice 2	(2M)	965-0069-00		U21	960-5010-00	Sound	(512K)	965-0205-00		U7	960-7001-02
Sound	(256K)	965-0070-00		U7	960-5007-00	Display*	(4M)	965-0206-00	A3.00	ROM 0	960-5015-00
Display	(1M)	965-0071-00	A1.06	U8	960-5009-00	Display*	(4M)	965-0207-00	A3.00	ROM 3	960-5015-00</

APPENDIX B

Semi-Conductors / Integrated Circuits (I.C.) / Relays Cross-Reference Table

Table No	Type	Source Number	STERN® PINBALL	N T E®	E C G®	Radio Shack®	R C A®
RECTIFICATION, BLOCKING, DAMPENING DIODES AND/OR LIGHT EMITTING DIODES (LEDs)							
1	Diode	1N4001	112-5001-00	NTE552	ECG552	- - - - -	SK9000
	Diode	1N4004	112-5003-00	NTE116	ECG116	276-1103	SK3312
	Diode	1N5401	112-0056-00	NTE5801	ECG5801	276-1143	SK9004
	Diode	1N5404	112-5004-00	NTE5804	ECG5804	276-1144	SK9007
	Diode	T6A10L	112-5006-01	NTE5812	ECG5812	- - - - -	- - - - -
	Diode	FR302	112-5009-00	NTE588	ECG588	- - - - -	SK5014
	Diode, Signal	1N914	112-5014-00	- - - - -	- - - - -	- - - - -	- - - - -
	LED	MT5000UR or TLRH180P (T1-3/4 GaAlAs)	165-5052-00 <i>(old SPI Part No: 165-5100-00)</i>	- - - - -	- - - - -	276-066B	- - - - -
ZENER DIODES							
2	Diode	1N4742A 12v	112-0061-00	NTE142A	ECG142A	276-563	SK12V
	Diode	1N4760B 68v	112-0062-00B	NTE5092A	ECG5092A	- - - - -	SK68V
	Diode	1N4764A 100v	112-0049-00A	NTE5096A	ECG5096A	- - - - -	SK100V
	Diode	1N5228 3.9v	112-0053-00	NTE5007A	ECG5007A	- - - - -	SK3A9
	Diode	1N5234B 6.2v	112-0047-00B	NTE5013A	ECG5013A	276-561	SK6A2
	Diode	1N5379 110v	112-0072-00	NTE5157	ECG5157	- - - - -	SK110X
	Diode	1N6267A 6.8v	112-5011-00	NTE4902	ECG4902	- - - - -	- - - - -
	Diode	1N4752A 33v	112-5010-00A	NTE147A	ECG147A	- - - - -	SK33V
	Diode	1N4736 6.8v 1w	112-5007-00	NTE5071A	ECG5071A	- - - - -	- - - - -
TRANSISTORS - TYPE FET, NPN, PNP AND/OR SCR							
3	FET Trans.	STP20N10L	110-0106-00	NTE2987	ECG2987	- - - - -	- - - - -
	FET Trans.	STP19N06L	110-0088-00	NTE2985	ECG2985	- - - - -	- - - - -
	FET Trans.	VN02N	110-0089-00	- - - - -	- - - - -	- - - - -	- - - - -
	NPN Trans.	2N4401	110-0073-00	NTE85	ECG85	276-2009	SK3124A
	NPN Trans.	2N6427	110-0070-00	NTE48	ECG48	- - - - -	SK4906
	NPN Trans.	MJE340	110-0071-00	NTE157	ECG157	- - - - -	SK3747
	NPN Trans.	MPSA42	110-0082-00	NTE287	ECG287	- - - - -	SK3232
	NPN Trans.	2N3904	110-0069-00	NTE123AP	ECG123AP	276-2009	- - - - -
	NPN Trans.	TIP122	110-0067-00	NTE261	ECG261	276-2068	SK3896
	NPN Trans.	MJE15030	110-0101-00	NTE375	ECG375	- - - - -	SK9118
	PNP Trans.	2N5401	110-0078-00	NTE288	ECG288	- - - - -	SK3434
	PNP Trans.	MJE15031	110-0103-00	NTE292	ECG292	- - - - -	SK3441
	PNP Trans.	MJE350	110-0072-00	NTE374	ECG374	- - - - -	SK9042
	PNP Trans.	MPSA92	110-0100-00	NTE288	ECG278	- - - - -	SK3434
	PNP Trans.	TIP42	110-0068-00	NTE332	ECG332	- - - - -	SK9236
	PNP Trans.	TIP32C	110-0081-00	NTE292	ECG292	- - - - -	SK3441
	PNP Trans.	TIP36C	110-0077-00	NTE393	ECG393	- - - - -	SK3961
	SCR Trans.	2N5060	110-0074-00	NTE5400	ECG5400	276-1067	SK3950
SCR Trans.	SCR2800B	110-0083-00	NTE5461-8	ECG5461-8	- - - - -	- - - - -	
BRIDGE RECTIFIERS (BR)				Comments:			
4	BR (Present)	DB3501 or CM3501	112-5000-00	For White Star I/O Bds., BR = 35 Amp @ 100v P.I.V.			
	RELAYS				Comments:		
5	Relay	FRL-264 D024/02CK	190-5002-00	For PPB, Power Supply, & White Star I/O Boards, Relay = 24v DC 10 Amp DPDT			
	Relay	FRL-264 D006/04CV	190-5001-00	For CPU Boards, Relay = 6v DC 5 Amp 4 Pole DT			





APPENDIX C

Production Start Date, Manual Part No., ROM Size & Positions and Jumper W6 Installed Note‡ (White Star Board System & S.A.M. System Only*)



Game Name White Star Bd. System™	Production Start Date and Manual Part Nr.	CPU/Sound Board Sound U7 512K CPU/Sound Board Game U210 1MB CPU/Sound Board Voice ROMS:				Jumper Installed (‡ see Note)	
		U17	U21	U36	U37		
<p>* Note: For complete Appendix Information for Games <i>Laser War</i> through <i>Batman Forever</i>, see any Service Game Manual between <i>Apollo 13</i> through <i>Ripley's Believe It or Not!</i> or on-line at our website www.sternpinball.com/parts.htm; also available on CD-R, 970-2003-00 (<i>The Simpsons™ Pinball Party</i>, <i>T3@</i> and <i>The Lord of the Rings™</i>).</p>							
29	Apollo 13 (A13)	NOV 95 780-5044-00	4MB	4MB	4MB	Not Used	n / a
30	Golden Eye	FEB 96 780-5042-00	4MB	4MB	Not Used	Not Used	n / a
31	Twister	APR 96 780-5041-00	4MB	4MB	Not Used	Not Used	n / a
32	ID4: Independence Day	JUL 96 780-5045-00	4MB	4MB	Not Used	Not Used	n / a
33	Space Jam	OCT 96 780-5043-00	4MB	4MB	4MB	Not Used	n / a
34	The Star Wars Trilogy - Sp. Ed.	FEB 97 780-5056-00	4MB	4MB	Not Used	Not Used	n / a
35	The Lost World: Jurassic Park	JUN 97 780-5053-00	4MB	4MB	Not Used	Not Used	n / a
36	The X-Files	AUG 97 780-5046-00	4MB	4MB	Not Used	Not Used	n / a
37	Starship Troopers	NOV 97 780-5059-00	4MB	4MB	4MB	Not Used	n / a
38	Viper Night Drivin'	FEB 98 780-5035-00	4MB	4MB	4MB	4MB	n / a
39	Lost In Space	JUN 98 780-5060-00	4MB	4MB	4MB	4MB	n / a
40	Godzilla	SEP 98 780-5040-00	4MB	4MB	4MB	4MB	n / a
41	South Park	JAN 99 780-5071-00	8MB	8MB	8MB	8MB	W6
42a	Harley-Davidson®	AUG 99 780-5067-01	8MB	8MB	8MB	8MB	W6
42b	Harley-Davidson® 2nd Ed.	SEP 02 780-5067-10	8MB	8MB	8MB	8MB	W6
42c	Harley-Davidson® 3rd Ed.	OCT 04 780-5087-00	8MB	8MB	8MB	8MB	W6
43a	Striker Xtreme	MAR 00 780-5068-01	8MB	8MB	8MB	8MB	W6
43b	NFL	OCT 00 780-5073-00	8MB	8MB	8MB	8MB	W6
44	Sharkey's Shootout	JUL/OCT 00 780-5072-01	8MB	8MB	8MB	Not Used	W6
45	High Roller Casino	JAN 01 780-5065-00	8MB	8MB	8MB	8MB	W6
46	Austin Powers™	MAY 01 780-5074-00	8MB	8MB	8MB	8MB	W6
47	MONOPOLY®	SEP 01 780-5075-00	8MB	8MB	8MB	Not Used	W6
48	Playboy	FEB 02 780-5076-00	8MB	8MB	8MB	8MB	W6
49	RollerCoaster Tycoon™	AUG 02 780-5078-00	8MB	8MB	8MB	Not Used	W6
50	The Simpsons™ Pinball Party	JAN 03 780-5077-00	8MB	8MB	8MB	8MB	W6
51	T3@: Rise of the Machines™	MAY 03 780-5079-00	8MB	8MB	8MB	8MB	W6
52	The Lord of the Rings™	NOV 03 780-5080-00	8MB	8MB	8MB	8MB	
53	Ripley's Believe It or Not!®	APR 04 780-5081-00	8MB	8MB	8MB	8MB	

‡ Additional Information for Installed Jumper (above games 41-51):

- Installed **W6** so 8MB ROMS can be utilized. See the **CPU/Sound Board Schematic** (Sheet 2 of 3, Address Location 3E) in the games' Service Game Manual. Games 52 - 57 CPU/Sound Board differ than <51 (See Appendix D).

See **Apdx. A** for more detailed information on **Pinball Game Firmware** (ROM Name, Size, Part Numbers, USA Version & Checksum and Board Locations).

Game Name White Star Board System™	Production Start Date and Manual Part Nr.	CPU/Sound Board Sound U7 512K CPU/Sound Board Game U210 1MB CPU/Sound Board Voice ROMS:				
		U17	U21	U36	U37	
54	Elvis®	AUG 04 780-5084-00	8MB	8MB	8MB	8MB
55	The Sopranos™	FEB 05 780-5085-00	8MB	8MB	8MB	8MB
56	NASCAR®	JUL 05 780-5086-00	8MB	8MB	8MB	8MB
57	Grand Prix	SEP 05 780-5091-00	8MB	8MB	8MB	8MB

See **Apdx. A** for more detailed information on **Pinball Game Firmware** (ROM Name, Size, Part Numbers, USA Version & Checksum and Board Locations).

Game Name S.A.M. System	Production Start Date and Manual Part Nr.	S.A.M. System CPU/Sound Board Boot EPROM U9			
		965-BOOT-SAM (Programmed)			
58	World Poker Tour™ (WPT)	JUN 06 780-5088-00	8MB	B-02 V2.1+ chksum \$F625	LOC: U9
59	The Simpsons™ Kooky Carnival	APR 06 780-5090-00	8MB	B-02 V2.1+ chksum \$F625	LOC: U9
60	©Disney's Pirates of the Caribbean	AUG 06 780-5092-00	8MB	B-02 V2.1+ chksum \$F625	LOC: U9
61	Famil Guy™	DEC 06 780-5093-00	8MB	B-02 V2.1+ chksum \$F625	LOC: U9
62	Spider-Man™	MAY 07 780-5094-00	8MB	B-02 V2.1+ chksum \$F625	LOC: U9

Games 58 – current, S.A.M. System : CPU/Sound & I/O Power Driver PCBs differ than White Star (previous Games 29 – 57); Disp. Controller Not Required.





APPENDIX D

Board Type (White Star Board System* Only) Table



Game Name	Flipper	I/O Power Driver	CPU/Sound Stereo	Disp. Power Supply	Dot Matrix Display	Display Controller	OPTO Transmitter	OPTO Receiver	OPTO Application
Apollo 13	520-5080-00 2-Flipper	520-5137-00	520-5136-00	520-5138-00	520-5052-00 128 X 32 Dots	520-5055-01	520-5124-00 Single OPTO	520-5125-00 Single OPTO	5-Ball Trough over Up-Kicker
	Miscellaneous PC Boards:	Light Boards 520-5130-01, -04 & -05 Magnet Interface, 7-Segment Display & Light Bd. 520-5130-06 Magnet Driver Board 520-5130-02 Switch Membrane Board 520-5130-03				Relay Board 520-5010-00			
Golden Eye	520-5080-00 2-Flipper	520-5137-00	520-5136-00	520-5138-00	520-5052-00 128 X 32 Dots	520-5055-01	520-5124-00 Single OPTO	520-5125-00 Single OPTO	5-Ball Trough over Up-Kicker
	Miscellaneous PC Boards:	Light Boards 520-5128-05 through -08		Mag. Processor X2 Driver Bd. 520-5143-00	Relay Board 520-5010-00				

GAMES HEREON NO LONGER REQUIRE THE FLIPPER BOARD WITH THE WHITE STAR BOARD SYSTEM™

Game Name	I/O Power Driver	CPU/Sound Mono	Disp. Power Supply	Dot Matrix Display	Display Controller	OPTO Transmitter	OPTO Receiver	OPTO Application	Misc OPTO & App.
Twister	520-5137-01	520-5136-10	520-5138-00	520-5052-00 128 X 32 Dots	520-5055-01	520-5124-00 Single OPTO	520-5125-00 Single OPTO	5-Ball Trough over Up-Kicker	
	Miscellaneous PC Boards:	Light Boards 520-5145-01 through -07		Mag. Drv. Bd. 520-5143-00	Relay Board 520-5010-00				
Independence Day (ID4)	520-5137-01	520-5136-10	520-5138-00	520-5052-00 128 X 32 Dots	520-5055-01	520-5124-00 Single OPTO	520-5125-00 Single OPTO	4-Ball Trough over Up-Kicker	
	Miscellaneous PC Boards:	Light Boards 520-5149-01 through -10		Servo Mtr. Bd. 520-5152-00		520-5082-00 Long Hop OPTO	520-5083-00 Long Hop OPTO	Alien Head Enter	
Space Jam	520-5137-01	520-5136-10	520-5138-00	520-5052-00 128 X 32 Dots	520-5055-01	520-5124-00 Single OPTO	520-5125-00 Single OPTO	5-Ball Trough over Up-Kicker	
	Miscellaneous PC Boards:	2X 7-Segment Display Board 520-5153-00							
The Star Wars Trilogy - Special Ed.	520-5137-01	520-5136-10	520-5138-00	520-5052-00 128 X 32 Dots	520-5055-01	520-5124-00 Single OPTO	520-5125-00 Single OPTO	4-Ball Trough over Up-Kicker	
	Miscellaneous PC Boards:	Relay Board 520-5010-00							
The Lost World: J.P.	520-5137-01	520-5136-10	520-5138-00	520-5052-00 128 X 32 Dots	520-5055-01	520-5124-00 Single OPTO	520-5125-00 Single OPTO	4-Ball Trough over Up-Kicker	520-5162-00 2-Pos. Motor Sensor on Snagger Motor
	Miscellaneous PC Boards:	DC Relay Bd. 520-5066-00	Shaker Mtr. Bd. 520-5065-00						
The X-Files	520-5137-01	520-5136-10	520-5138-00	520-5052-00 128 X 32 Dots	520-5055-01	520-5124-00 Single OPTO	520-5125-00 Single OPTO	4-Ball Trough over Up-Kicker	520-5155-00 3-Pos. Motor Sensor on File Cab. Motor
	Miscellaneous PC Boards:					520-5082-00 Long Hop OPTO	520-5083-00 Long Hop OPTO	File Cabinet Enter	
Starship Troopers	520-5137-01	520-5136-15	520-5138-00	520-5052-00 128 X 32 Dots	520-5055-02	520-5124-00 Single OPTO	520-5125-00 Single OPTO	4-Ball Trough over Up-Kicker	
	Miscellaneous PC Boards:	4X 7-Segment Display Board 520-5166-00					520-5082-00 Long Hop OPTO	520-5083-01 Long Hop OPTO	L/R Orbit Lane Enter
Viper Night Drivin'	520-5137-01	520-5136-16	520-5138-00	520-5052-00 128 X 32 Dots	520-5055-03	520-5124-00 Single OPTO	520-5125-00 Single OPTO	4-Ball Trough over Up-Kicker	
	Miscellaneous PC Boards:	Relay Board 520-5010-00					520-5082-00 Long Hop OPTO	520-5083-01 Long Hop OPTO	Jump Ramp
Lost In Space	520-5137-01	520-5136-16	520-5138-00	520-5052-00 128 X 32 Dots	520-5055-03	515-0173-00 Dual OPTO	515-0174-00 Dual OPTO	4-Ball Trough over Up-Kicker	
	Miscellaneous PC Boards:	Relay Board 520-5010-00							
Godzilla	520-5137-01	520-5136-16	520-5138-00	520-5052-00 128 X 32 Dots	520-5055-03	515-0173-00 Dual OPTO	515-0174-00 Dual OPTO	4-Ball Trough over Up-Kicker	
	Miscellaneous PC Boards:	Shaker Mtr. Bd. 520-5065-00							
South Park	520-5137-01	520-5136-16	520-5138-00	520-5052-00 128 X 32 Dots	520-5055-03	515-0173-00 Dual OPTO	515-0174-00 Dual OPTO	5-Ball Trough over Up-Kicker	
	Miscellaneous PC Boards:					520-5082-00 Long Hop OPTO	520-5083-01 Long Hop OPTO	Kenny Under Trough Enter	
Harley-Davidson® 1st-3rd* Editions	520-5137-01	520-5136-16 *520-5300-00*	520-5138-00	520-5052-00 128 X 32 Dots	520-5055-03	515-0173-00 Dual OPTO	515-0174-00 Dual OPTO	4-Ball Trough over Up-Kicker	
	Miscellaneous PC Boards:	Relay Board 520-5010-00		Shaker Mtr. Bd. 520-5065-00	Diode Board 520-5146-00		520-5082-00 Long Hop OPTO	520-5083-01 Long Hop OPTO	Motorcycle Enter
Striker Xtreme (NFL)	520-5137-01	520-5136-16	520-5138-00	520-5052-00 128 X 32 Dots	520-5055-03	515-0173-00 Dual OPTO	515-0174-00 Dual OPTO	4-Ball Trough over Up-Kicker	520-5155-00 3-Pos. Motor Sensor on Goalie Motor
	Miscellaneous PC Boards:	DC Relay Bd. 520-5066-00	Relay Board 520-5010-00	Diode Board 520-5146-00	for UK ONLY- Solenoid Expander Bd. 520-5192-00	520-5082-00 Long Hop OPTO	520-5083-01 Long Hop OPTO	Goalie Under- Trough Enter	
Sharkey's Shootout	520-5137-64	520-5136-64	520-5138-00	520-5052-00 128 X 32 Dots	520-5055-03	515-0173-00 Dual OPTO	515-0174-00 Dual OPTO	4-Ball Trough over Up-Kicker	520-5194-00 4-Pos. Motor Sensor on ? -Ball Motor
	Miscellaneous PC Boards:	Relay Board 520-5010-00		Sol. Exp. Bd. 520-5192-00					
High Roller Casino	520-5137-01	520-5136-16	520-5138-00	520-5052-00 128 X 32 Dots	520-5055-03	515-0173-00 Dual OPTO	515-0174-00 Dual OPTO	4-Ball Trough over Up-Kicker	520-5194-00 4-Pos. Motor Sensor on Roulette Wheel Motor
	Miscellaneous PC Boards:	Dot Display (5X7) in Slot Mach. 520-5197-00			for UK ONLY- Solenoid Expander Bd. 520-5192-00		520-5082-00 Long Hop OPTO	520-5083-01 Long Hop OPTO	Ball Lock under Roulette
Austin Powers™	520-5137-01	520-5136-16	520-5138-00	520-5052-00 128 X 32 Dots	520-5055-03	515-0173-00 Dual OPTO	515-0174-00 Dual OPTO	4-Ball Trough over Up-Kicker	520-5212-00 Pulse-Stretcher OPTO on Spini-Me
	Miscellaneous PC Boards:	Relay Bd. (X3) 520-5010-00			for UK ONLY- Solenoid Expander Bd. 520-5192-00	520-5082-00 Long Hop OPTO	520-5083-01 Long Hop OPTO	Time Machine Ramp	
MONOPOLY®	520-5137-01	520-5136-16	520-5138-00	520-5052-00 128 X 32 Dots	520-5055-03	515-0173-00 Dual OPTO	515-0174-00 Dual OPTO	4-Ball Trough over Up-Kicker	
	Miscellaneous PC Boards:	DC Relay Bd. 520-5066-00	Mini-Dot Display (3 by 5X7) 520-5197-00 (Electric C- Sign)		for UK ONLY- Solenoid Expander Bd. 520-5192-00	520-5218-00 4-Pos. OPTO	520-5210-00 4-Pos. OPTO	Bank Door	

Table continued on the next page.





APPENDIX D

Board Type (White Star Board System* & S.A.M. System** Only) Table



Game Name	I/O Power Driver	CPU/Sound (old & new)	Disp. Power Supply	Dot Matrix Display	Display Controller	OPTO Transmitter	OPTO Receiver	OPTO Application	Misc OPTO & App.
Playboy	520-5137-01	520-5136-16	520-5138-00	520-5052-00 128 X 32 Dots	520-5055-03	515-0173-00 Dual OPTO	515-0174-00 Dual OPTO	4-Ball Trough over Up-Kicker	
	Miscellaneous PC Boards:	DC Relay Bd. 520-5066-00	Relay Bd. 520-5010-00		for UK ONLY- Solenoid Expander Bd. 520-5192-00				
RollerCoaster Tycoon™	520-5137-01	520-5136-16	520-5138-00	520-5052-00 128 X 32 Dots	520-5055-03	515-0173-00 Dual OPTO	515-0174-00 Dual OPTO	4-Ball Trough over Up-Kicker	520-5222-00 1-Position Switch Detect on Wheel Spin
	Miscellaneous PC Boards:	DC Relay Bd. 520-5066-00	Mini-Dot Display (3 by 5X7) 520-5221-00 (Ramp Enter Sign)		for UK ONLY- Solenoid Expander Bd. 520-5192-00	520-5082-00 Long Hop OPTO	520-5083-01 Long Hop OPTO	Behind 1-Bank Drop Target	
The Simpsons™ Pinball Party	520-5137-01	520-5136-16	520-5138-00	520-5052-00 128 X 32 Dots	520-5055-03	515-0173-00 Dual OPTO	515-0174-00 Dual OPTO	4-Ball Trough over Up-Kicker	
	Miscellaneous PC Boards:	LED Bd. 520-5219-00	Color Dot Display (4 by 5X7) 520-5225-00 (TV Set)		for UK ONLY ◀◀◀ Aux. Driver Bd. 520-5068-01				
Terminator® 3: Rise of the Machines™	520-5137-01	520-5136-16	520-5138-00	520-5052-00 128 X 32 Dots	520-5055-03	515-0173-00 Dual OPTO	515-0174-00 Dual OPTO	4-Ball Trough over Up-Kicker	
	Miscellaneous PC Boards:				for UK ONLY ◀◀◀ Aux. Driver Bd. 520-5068-01	515-7307-00 Single OPTO	515-7308-00 Single OPTO	TXCannon Trough	
The Lord of the Rings™	520-5137-01	New 520-5300-00	520-5138-00	520-5052-00 128 X 32 Dots	520-5055-03	515-0173-00 Dual OPTO	515-0174-00 Dual OPTO	4-Ball Trough over Up-Kicker	500-6746-00 (White Trans.) 500-6747-00 (Black Rec.)
	Miscellaneous PC Boards:	19-LED PCB 520-5242-00	OPTO Transmitter / Receiver Amplifier PCB 520-5239-00		for UK ONLY ◀◀◀ Aux. Driver Bd. 520-5068-01	515-7307-00 Single OPTO	515-7308-00 Single OPTO	Orthanc Tower Trough	
Ripley's Believe It or Not!®	520-5137-01	520-5300-00	520-5138-00	520-5052-00 128 X 32 Dots	520-5055-03	515-0173-00 Dual OPTO	515-0174-00 Dual OPTO	4-Ball Trough over Up-Kicker	500-6775-00 OPTO Trnscvr
	Miscellaneous PC Boards:	520-5236-00 X3 Dot Display	OPTO Transmitter / Receiver Amplifier PCB 520-5239-01		for UK ONLY ◀◀◀ Aux. Driver Bd. 520-5068-01	520-5234-00 3-Pos. OPTO	520-5234-00 3-Pos. OPTO	Vari-Target	520-5235-03 X3 Aux. Drvr
Elvis®	520-5137-01	520-5300-00	520-5138-00	520-5052-00 128 X 32 Dots	520-5055-03	515-0173-00 Dual OPTO	515-0174-00 Dual OPTO	4-Ball Trough over Up-Kicker	
	Miscellaneous PC Boards:				for UK ONLY ◀◀◀ Aux. Driver Bd. 520-5068-01				
The Sopranos™	520-5137-01	520-5300-00	520-5138-00	520-5052-00 128 X 32 Dots	520-5055-03	515-0173-00 Dual OPTO	515-0174-00 Dual OPTO	4-Ball Trough over Up-Kicker	
	Miscellaneous PC Boards:				for UK ONLY ◀◀◀ Aux. Driver Bd. 520-5068-01				
NASCAR® and [INDSE]	520-5137-01	520-5300-00	520-5138-00	520-5052-00 128 X 32 Dots	520-5055-03	515-0173-00 Dual OPTO	515-0174-00 Dual OPTO	4-Ball Trough over Up-Kicker	500-6775-00 OPTO Trans. (Qty. 16) Switch Detect.
	Miscellaneous PC Boards:	520-5235-03 X3 Aux. Drvr	OPTO Transmitter / Receiver Amplifier PCB 520-5239-01		for UK ONLY ◀◀◀ Aux. Driver Bd. 520-5068-01				
Grand Prix	520-5137-01	520-5300-00	520-5138-00	520-5052-00 128 X 32 Dots	520-5055-03	515-0173-00 Dual OPTO	515-0174-00 Dual OPTO	4-Ball Trough over Up-Kicker	500-6775-00 OPTO Trans. (Qty. 16) Switch Detect.
	Miscellaneous PC Boards:	520-5235-03 X3 Aux. Drvr	OPTO Transmitter / Receiver Amplifier PCB 520-5239-01		for UK ONLY ◀◀◀ Aux. Driver Bd. 520-5068-01				

Game Name	I/O Power Driver**	CPU / Sound**	Disp. Power Supply	Dot Matrix Display	Dual OPTO Transmitter	Dual OPTO Receiver	Dual OPTO Transceiver	OPTO Transceiver Miscellaneous
World Poker Tour™ (WPT)	520-5249-00 Backbox	520-5246-00 Backbox	520-5138-00 Backbox	520-5052-00 128 X 32 Dots	515-0173-00 4-Ball Trough	515-0174-00 4-Ball Trough	500-6775-00 4 Switch Pairs (Qty. 8)	520-5251-00 'U' 1/per PCB Jail Bars Up Ace/Hole Mech 520-5252-04 'U' 4/per PCB Drop Targets 4- & 8- Banks
	Miscellaneous PCBs:	520-5254-00 50V Step-Up Drv	520-5250-14 14LED 5X7 Disp.	520-5239-01 OPTO Amplifier	520-5247-00 Ace/Hole Mech	520-5248-00 Ace/Hole Mech		
The Simpsons™ Kooky Carnival	520-5249-00 Back Door	520-5246-00 Back Door	520-5138-00 Cabinet Rear	520-5052-00 128 X 32 Dots			520-5253-00-ASY Coin Drop (Qty. 11)	
	Miscellaneous PCBs:	515-5742-00 Shaker PCB	500-6700-00 Relay (incl. Wiring + Conn.)					
©Disney's Pirates of the Caribbean	520-5249-00 Backbox	520-5246-00 Backbox	520-5138-00 Backbox	520-5052-00 128 X 32 Dots	515-0173-00 4-Ball Trough	515-0174-00 4-Ball Trough	500-6775-00 5 Switch Pairs (Qty. 10)	
	Miscellaneous PCBs:	520-5239-01 OPTO Amp. (X3)	511-5024-03 Relay (incl. Wiring + Conn.)	520-5238-00 : H-E-A-R-T LED PCB				
Family Guy™	520-5249-00 Backbox	520-5246-00 Backbox	520-5138-00 Backbox	520-5052-00 128 X 32 Dots	515-0173-00 4-Ball Trough	515-0174-00 4-Ball Trough	500-6775-00 3 Switch Pairs (Qty. 6)	520-5252-01 'U' 1/per PCB Drop Target 1-Bank
	Miscellaneous PCBs:	520-5239-01 OPTO Amp. (X2)	520-5261-00 Stepper Motor	511-5042-01 Trgt. Sensor (X2)			500-6775-01 1 Switch Pair (Qty. 2)	520-5252-04 'U' 4/per PCB Drop Target 4-Bank
Spider-Man™	520-5249-00 Backbox	520-5246-00 Backbox	520-5138-00 Backbox	520-5052-00 128 X 32 Dots	515-0173-00 4-Ball Trough	515-0174-00 4-Ball Trough	500-6775-00 3 Switch Pairs (Qty. 6)	
	Miscellaneous PCBs:	520-5239-01 OPTO Amp. (X2)						



APPENDIX D

Board Type Table

Game Name	Flipper	Sound	Power Supply	Display X-Digit
• Laser War	2-Flipper Board Not Required	<i>initial:</i> 520-5002-00 <i>replaced with:</i> 520-5002-02 <i>520-5002-01 was not used.</i>	520-5000-00	Master: 520-5004-00 plus: 520-5005-00 (Qty. 2); 7 Digit Alpha/Numeric 520-5006-00 (Qty. 2); 7 Digit Numeric 520-5007-00 (Qty. 1); 4 Digit Numeric
• Secret Service • Torpedo Alley	3-Flipper Board Not Required	520-5002-02		520-5014-01 7 Digit Alpha/Numeric Combined
• Time Machine	2-Flipper Board Not Required			520-5030-00 16 Digit Alpha/Numeric Combined
• Playboy 35th Anniversary *	520-5033-00 2-Flipper <i>(*only for 100 games of Playboy 35th Anniv. & ABC Mon. Night Football)</i>			
• ABC Monday Night Football *				
• Robocop				
• Phantom of the Opera				
• Back to the Future		520-5002-03		
• The Simpsons				

Game Name	Flipper	Sound	Power Supply	Dot Matrix Display	Display Controller	OPTO Transmitter	OPTO Receiver	OPTO Application
• Checkpoint • Teenage Mutant Ninja Turtles	520-5033-00 2-Flipper	520-5002-03	520-5047-00	520-5042-00 128 X 16	520-5055-00			
• Batman • Star Trek 25th Anniv. • Hook		520-5050-01						
• Lethal Weapon 3		520-5050-02	520-5047-01					
• Star Wars • Rocky & Bullwinkle & Friends			520-5052-00 128 X 32					
• Jurassic Park				520-5076-00 3-Flipper				
• Last Action Hero	520-5070-00 2-Flipper	520-5050-03	520-5047-02	520-5055-01				
• Tales from the Crypt	520-5076-00 3-Flipper	520-5077-00						
• WWF Royal Rumble	520-5070 / 5080 -00 4-Flipper (2X2)	520-5050-03	520-5047-03	520-5075-00 192 X 64	520-5092-01	520-5102-00 Single OPTO	520-5103-00 Single OPTO	Paddle Boat Wheel Enter
• Guns N' Roses	520-5076-00 3-Flipper							
• Maverick	520-5076-00 3-Flipper							
• Mary Shelley's Frankenstein	520-5076-00 3-Flipper	520-5077-00				520-5124-00 Single OPTO	520-5125-00 Single OPTO	5-Ball Trough over Up-Kicker
• Baywatch	520-5070 / 5080 -00 4-Flipper (2X2)	520-5126-02				520-5124-00 Single OPTO	520-5125-00 Single OPTO	4-Ball Trough over Up-Kicker
• Batman Forever	520-5076-00 3-Flipper							

Miscellaneous Boards (Lamp Boards & Relay Boards) not listed above can be found in each individual game manual.





APPENDIX E

Flipper Coil (White Star Board System* & S.A.M. System** Only) Table



Typical Coil Diode 1N4004 unless noted otherwise (Diode Top = above lugs next to windings; Diode Below (Bottom) = under lugs opposite of windings).

STANDARD COILS (TYPICAL APPLICATIONS)			LARGE COILS (FLIPPERS & SPECIAL APPLICATIONS)		
Ga.-Turn	Res (Ω)	SPI Part Number and Comments	Ga.-Turn	Res (Ω)	SPI Part Number and Comments
20-400	1.0 Ω	090-5021-use : -00 Diode Top	21-900	call Ω	090-5020-use : -01 3-Lugs + 1N4004 & 1N5404 Diodes -10 Diode Top <BROWN><RED>
22-500	1.7 Ω	090-5017-use : -00 Diode Top	22-750 / 30-2600	2.6 Ω 92.0 Ω	090-5011-use : -00 DUAL WND COIL // 3-Lugs Diode x2
22-600	2.2 Ω	090-5017-use : -0B Diode Below // -0T Diode Top			
23-700	3.1 Ω	090-5022-use : -0B Diode Below // -0T Diode Top	22-900	3.45 Ω	090-5020-use : -20T Diode Top <YELLOW> // -20-ND No Diode
23-750	3.4 Ω	090-5019-use : -00 Diode Top			
23-800	3.6 Ω	090-5001-use : -0B Diode Below // -0T Diode Top // -NL No Lugs 11" Leads // -ND No Diode	22-1080	4.2 Ω	090-5032-use : -0B D. Below // -0T D. Top <YEL-GRN> -NL No Diode
23-840	4.0 Ω	090-5005-use : -00 Diode Top			
23.5-765	3.6 Ω	090-5037-use : -03 Diode Top	23-620 / 30-2600	2.4 Ω 75.0 Ω	090-5006-use : -00 DUAL WND COIL // 3-Lugs Diode x2
24-900	5.0 Ω	090-5002-use : -02 Diode Top // -10 No Lugs 14" Leads			
24-940	5.5 Ω	090-5036-use : -0B Diode Below // -0T Diode Top use 090-5051-01 No Lugs 11" Leads	23-700 / 30-2600	3.0 Ω 83.5 Ω	090-5013-use : -00 DUAL WOUND COIL // Diode Top
25-1240	9.3 Ω	090-5034-use : -00 Diode Below			
26-1200	10.3 Ω	090-5044-use : -0B Diode Below // -0T Diode Top // -NL No Lugs 11" Leads // -ND No Diode	23-800 / 30-2600	2.4 Ω 90.5 Ω	090-5012-use : -00 DUAL WOUND COIL // Diode Top
27-1300	14.2 Ω	090-5003-use : -0T Diode Top			
27-1400	14.7 Ω	090-5015-use : -00 Diode Below	23-1100	5.1 Ω	090-5030-use : -0T Diode Top <ORANGE> -ND No Diode
27-1400	14.7 Ω	511-5031-00 Special App.: No Diode / Lugs + Conn.			
27-1500	16.3 Ω	090-5004-use : -0B Diode Below // -0T Diode Top	23-1200	7.1 Ω	090-5008-use : -00 Diode Top <BLACK>
29-2000	33.6 Ω	090-5016-use : -00 Diode Top	23-1500	4.4 Ω	090-5062-use : -00 Diode Top <BLUE>
LARGE, MEDIUM & MINI COILS (MAGNET APPLICATIONS)			24-1570	9.5 Ω	090-5025-use : -00 Diode Top <BLUE>
20.5-480	2.9 Ω	090-5064-use : -02 No Lugs or Core; 14" Leads // Large	25-1400	call Ω	090-5067-use : -0T Diode Top <RED>
22-650	4.3 Ω	090-5042-use : -00 No Lugs or Core; 6" Leads // Large	25-1600	call Ω	090-5068-use : -0T Diode Top <WHITE>
		090-5042-use : -01 No Lugs or Core; 12" Leads // Large	25-1800	13.8 Ω	090-5041-use : -0T Diode Top <BLUE-GREEN>
24-780	8.0 Ω	090-5061-use : -00 No Lugs or Core; 6" Lds. // Medium	MINI COILS (RESET / TRIP APPLICATIONS)		
29-1000	15.2 Ω	090-5059-use : -00 Lugs + Diode + Magnet Core // Mini	27-950	call Ω	090-5046-use : -01 Diode Top
31-1500	52.0 Ω	090-5054-00 : Straight Lugs + Diode + Mag Core // Mini	28-1050	11.5 Ω	090-5046-use : -00 Diode Top
		090-5055-00 : 90° Lugs + Diode + Magnet Core // Mini	27-880	call Ω	500-6976-01 No Lugs or Diode + 6" Leads & Conn.
Please Note: Ohm values may vary +/- .03 depending on meter calibration.			31-590	call Ω	090-5010-use : -00 Diode Top
Ordering Note: Coils typically should not come with Coil Sleeves. IF A SLEEVE EXISTS, ensure it is the correct sleeve for the application usage. For the correct Coil Sleeve, refer to the Game Assembly Drawing the coil exists on and order separately.			32-1250	35.0 Ω	515-6916-01 : includes Flap & Screw <YELLOW>
			32-1800	50.2 Ω	090-5031-use : -0B Diode Below // -0T Diode Top (515-6110-00) use 515-# to include mounting & armature brackets
			33-1590	59.0 Ω	515-6916-00 : includes brackets <WHITE>

Flipper Coil (White Star Board System* Only) Table

GAME NAME	Nº of Flippers	FLIPPERS		FLIPPERS no E.O.S. Switch	
		SPI Nº / GAUGE-TURNS / Color		SPI Nº / GAUGE-TURNS / Color	
		LOWER LEFT	LOWER RIGHT	UPPER LEFT	UPPER RIGHT
Apollo 13	2	090-5032-0T 22-1080 -YEL-GRN-	SAME	Not Used	Not Used
Golden Eye	2	090-5032-0T 22-1080 -YEL-GRN-	SAME	Not Used	Not Used
Twister	2	090-5020-20T 22-900 -YELLOW-	090-5032-0T 22-1080 -YEL-GRN-	Not Used	Not Used
ID4: Independence Day	3	090-5032-0T 22-1080 -YEL-GRN-	SAME	Not Used	090-5020-30 23-900 -GREEN-
Space Jam †	2	090-5032-0T 22-1080 -YEL-GRN-	090-5020-20T 22-900 -YELLOW-	Not Used	Not Used
The Star Wars Trilogy - Special Edition †	2	090-5032-0T 22-1080 -YEL-GRN-	SAME	Not Used	Not Used
The Lost World: Jurassic Park †	2	090-5032-0T 22-1080 -YEL-GRN-	SAME	Not Used	Not Used
The X-Files †	2	090-5032-0T 22-1080 -YEL-GRN-	SAME	Not Used	Not Used
Starship Troopers †	3	090-5030-0T 23-1100 -ORANGE-	SAME	Not Used	090-5032-0T 22-1080 -YEL-GRN-
Viper Night Drivin' †	2	090-5030-0T 23-1100 -ORANGE-	SAME	Not Used	Not Used
Lost In Space †	2	090-5030-0T 23-1100 -ORANGE-	090-5032-0T 22-1080 -YEL-GRN-	Not Used	Not Used
Godzilla †	2	090-5032-0T 22-1080 -YEL-GRN-	SAME	Not Used	Not Used
South Park †	2	090-5030-0T 23-1100 -ORANGE-	SAME	Not Used	Not Used

† Coil Part Numbers ending with a "T" signifies the Diode is on the top of the lug (on the coil-winding side); Coil Part Numbers ending with a "B" signifies the Diode is on the bottom of the lugs.

Table continued on the next page.





APPENDIX E

Flipper Coil (White Star Board System* & S.A.M. System** Only) Table



GAME NAME	N ^o of Flippers	FLIPPERS w/E.O.S. Switch		FLIPPERS no E.O.S. Switch	
		SPI N ^o / GAUGE-TURNS / Color		SPI N ^o / GAUGE-TURNS / Color	
		LOWER LEFT	LOWER RIGHT	UPPER LEFT	UPPER RIGHT
Harley-Davidson® † and 1st through 3rd Editions	2	090-5032-0T 22-1080 -YEL-GRN-	090-5030-0T 23-1100 -ORANGE-	Not Used	Not Used
Striker Xtreme (NFL) †	3	090-5032-0T 22-1080 -YEL-GRN-	090-5030-0T 23-1100 -ORANGE-	090-5030-0T 23-1100 -ORANGE-	Not Used
Sharkey's Shootout †	3	090-5030-0T 23-1100 -ORANGE-	SAME	090-5030-0T 23-1100 -ORANGE-	Not Used
High Roller Casino †	2	090-5032-20T 22-900 -YELLOW-	090-5032-0T 22-1080 -YEL-GRN-	Not Used	Not Used
Austin Powers™ †	2	090-5020-30 23-900 -GREEN-	090-5030-0T 23-1100 -ORANGE-	Not Used	Not Used
MONOPOLY® †	3	090-5032-0T 22-1080 -YEL-GRN-	SAME	Not Used	090-5062-0T 23-1500 -BLUE-
Playboy †	2	090-5030-0T 23-1100 -ORANGE-	SAME	Not Used	Not Used
RollerCoaster Tycoon™ †	4	090-5032-0T 22-1080 -YEL-GRN-	SAME	090-5067-0T 25-1400 -RED-	090-5068-0T 25-1600 -WHITE-
The Simpsons™ Pinball Party †	6** (5 with Flipper Bats)	090-5032-0T 22-1080 -YEL-GRN-	SAME	Not Used	090-5030-0T 23-1100 -ORANGE-
		<i>** The Homer Head Assembly is affixed to an Upr. Rt. Style Flipper (no E.O.S. Switch):</i>		Flippers (Mini-Bats) on 2nd Level Playfield:	
			** 090-5020-20T 22-900 -YELLOW-	090-5041-00T 25-1800 -BLU-GRN-	090-5025-00 24-1570 -BLUE-
Terminator® 3: Rise of the Machines™ †	2	090-5032-0T 22-1080 -YEL-GRN-	SAME	Not Used	Not Used
The Lord of the Rings™ †	2	090-5020-20T 22-900 -YELLOW-	SAME	Not Used	Not Used
Ripley's Believe It or Not!® †	3	090-5032-0T 22-1080 -YEL-GRN-	SAME	Not Used	090-5067-00T 25-1400 -RED-
Elvis® †	4	090-5020-20T 22-900 -YELLOW-	SAME	090-5020-30 23-900 -GREEN-	SAME
The Sopranos™ †	2	090-5032-0T 22-1080 -YEL-GRN-	SAME	Not Used	Not Used
NASCAR® and [NDSE] †	2	090-5030-0T 23-1100 -ORANGE-	SAME	Not Used	Not Used
Grand Prix †	2	090-5030-0T 23-1100 -ORANGE-	SAME	Not Used	Not Used
† Coil Part Numbers ending with a "T" signifies the Diode is on the top of the lug (on the coil-winding side); Coil Part Numbers ending with a "B" signifies the Diode is on the bottom of the lugs.					
** S.A.M. System Games DO NOT REQUIRE DIODES. If you use a coil from your stock which has a diode, remove it ONLY FOR S.A.M. System Games.					
World Poker Tour™ (WPT)**	4	090-5032-ND 22-1080 [NO DIODE]	SAME	090-5030-ND 23-1100 [NO DIODE]	SAME
©Disney's Pirates of the Caribbean**	2	090-5030-ND 23-1100 [NO DIODE]	SAME	Not Used	Not Used
Family Guy™ **	3 Norm.	090-5030-ND 23-1100 [NO DIODE]	SAME	090-5062-ND 23-1500 [NO DIODE]	Not Used
	2 Mini	090-5046-01-ND 27-950 [NO DIODE]	SAME		
Spider-Man™ **	3	090-5032-ND 22-1080 [NO DIODE]	SAME	Not Used	090-5032-ND 22-1080 [NO DIODE]



APPENDIX E

Generic Coil Cross-Reference Guide † ‡

Flipper Coil Table ‡ ††

GAME NAME	Nº of Flippers	FLIPPERS w/E.O.S. Switch		FLIPPERS no E.O.S. Switch	
		SPI Nº / GAUGE-TURNS / Color		SPI Nº / GAUGE-TURNS / Color	
		LOWER LEFT	LOWER RIGHT	UPPER LEFT	UPPER RIGHT
Laser War ‡	2	090-5011-00 22-750 / 30-2600	SAME	Not Used	Not Used
Secret Service ‡	3	090-5006-00 23-620 / 30-2600	SAME	Not Used	090-5006-00 23-620 / 30-2600
Torpedo Alley ‡	3	090-5011-00 22-750 / 30-2600	090-5013-00 23-700 / 30-2600	Not Used	090-5012-00 23-800 / 30-2600
Time Machine ‡	2	090-5011-00 22-750 / 30-2600	SAME	Not Used	Not Used
‡ These coils are dual-wound.					
Playboy 35th Anniversary ††	2	090-5020-02 22-900 -YEL-YEL-	SAME	Not Used	Not Used
ABC Monday Night Football ††	2	090-5020-02 22-900 -YEL-YEL-	SAME	Not Used	Not Used
†† A very small % of these games used a 090-5020-20 coil which used a proto-type Solid State Flipper System. The two types of coils both are 22-900 coils; the only difference is the addition of the 1N5404 Diode on the (-02) coils which was used in the Deger Design.					
Robocop	2	090-5020-20 22-900 -YEL-YEL-	SAME	Not Used	Not Used
Phantom of the Opera	2	090-5020-20 22-900 -YEL-YEL-	SAME	Not Used	Not Used
Back to the Future	2	090-5020-20 22-900 -YEL-YEL-	SAME	Not Used	Not Used
The Simpsons	2	090-5020-20 22-900 -YEL-YEL-	SAME	Not Used	Not Used
Checkpoint	2	090-5020-20 22-900 -YEL-YEL-	SAME	Not Used	Not Used
Teenage Mutant Ninja Turtles	2	090-5020-30 23-900 -GRN-GRN-	SAME	Not Used	Not Used
Batman	2	090-5020-30 23-900 -GRN-GRN-	SAME	Not Used	Not Used
Star Trek 25th Anniversary	2	090-5020-30 23-900 -GRN-GRN-	SAME	Not Used	Not Used
Hook	2	090-5030-00 23-1100 -ORG-ORG-	090-5020-30 23-900 -GRN-GRN-	Not Used	Not Used
Lethal Weapon 3	2	090-5030-00 23-1100 -ORG-ORG-	SAME	Not Used	Not Used
Star Wars	2	090-5032-00 22-1080 -YEL-GRN-	SAME	Not Used	Not Used
Rocky & Bullwinkle & Friends	2	090-5020-30 23-900 -GRN-GRN-	SAME	Not Used	Not Used
Jurassic Park	3	090-5020-30 23-900 -GRN-GRN-	SAME	Not Used	090-5030-00 23-1100 -ORG-ORG-

Table continued on the next page.



APPENDIX E

Flipper Coil Table †

GAME NAME	N ^o of Flippers	FLIPPERS w/ E.O.S. Switch		FLIPPERS no E.O.S. Switch	
		SPI N ^o / GAUGE-TURNS / Color		SPI N ^o / GAUGE-TURNS / Color	
		LOWER LEFT	LOWER RIGHT	UPPER LEFT	UPPER RIGHT
Last Action Hero	2	090-5020-30 23-900 -GRN-GRN-	SAME	Not Used	Not Used
Tales from the Crypt	3	090-5032-00 22-1080 -YEL-GRN-	SAME	Not Used	090-5041-00 25-1800 -BLU-GRN-
The Who's Tommy	3	090-5020-30 23-900 -GRN-GRN-	SAME	090-5041-00 25-1800 -BLU-GRN-	Not Used
WWF Royal Rumble	4	090-5032-00 22-1080 -YEL-GRN-	SAME	090-5041-00 25-1800 -BLU-GRN-	SAME
Guns N' Roses	3	090-5032-00 22-1080 -YEL-GRN-	SAME	090-5030-00 23-1100 -ORG-ORG-	Not Used
Maverick	3	090-5032-00 22-1080 -YEL-GRN-	SAME	Not Used	090-5032-00 22-1080 -YEL-GRN-
Mary Shelley's Frankenstein	3	090-5030-00 23-1100 -ORG-ORG-	SAME	Not Used	090-5030-00 23-1100 -ORG-ORG-
Baywatch	4	090-5030-00 23-1100 -ORG-ORG-	090-5020-30 23-900 -GRN-GRN-	090-5025-00 24-1570 -See Note-	090-5030-00 23-1100 -ORG-ORG-
Batman Forever	3	090-5032-00 22-1080 -YEL-GRN-	090-5020-20 22-900 -YEL-YEL-	Not Used	090-5020-30 23-900 -GRN-GRN-
Apollo 13	2	090-5032-00 22-1080 -YEL-GRN-	SAME	Not Used	Not Used
Golden Eye	2	090-5032-00 22-1080 -YEL-GRN-	SAME	Not Used	Not Used
Twister	2	090-5020-20 22-900 -YEL-YEL-	090-5032-00 22-1080 -YEL-GRN-	Not Used	Not Used
ID4: Independence Day	3	090-5032-00 22-1080 -YEL-GRN-	SAME	Not Used	090-5020-30 23-900 -GRN-GRN-
Space Jam †	2	090-5032-00T 22-1080 -YEL-GRN-	090-5020-20T 22-900 -YEL-YEL-	Not Used	Not Used
The Star Wars Trilogy - Special Edition †	2	090-5032-00T 22-1080 -YEL-GRN-	SAME	Not Used	Not Used
The Lost World: Jurassic Park †	2	090-5032-00T 22-1080 -YEL-GRN-	SAME	Not Used	Not Used
The X-Files †	2	090-5032-00T 22-1080 -YEL-GRN-	SAME	Not Used	Not Used
Starship Troopers †	3	090-5030-00T 23-1100 -ORG-ORG-	SAME	Not Used	090-5032-00T 22-1080 -YEL-GRN-
Viper Night Drivin' †	2	090-5030-00T 23-1100 -ORG-ORG-	SAME	Not Used	Not Used
Lost In Space †	2	090-5030-00T 23-1100 -ORG-ORG-	090-5032-00T 22-1080 -YEL-GRN-	Not Used	Not Used
Godzilla †	2	090-5032-00T 22-1080 -YEL-GRN-	SAME	Not Used	Not Used
South Park †	2	090-5030-00T 23-1100 -ORG-ORG-	SAME	Not Used	Not Used
Harley-Davidson® † and Harley-Davidson® 2nd Ed. †	2	090-5032-00T 22-1080 -YEL-GRN-	090-5030-00T 23-1100 -ORG-ORG-	Not Used	Not Used
Striker Xtreme (NFL) †	3	090-5032-00T 22-1080 -YEL-GRN-	090-5030-00T 23-1100 -ORG-ORG-	090-5030-00T 23-1100 -ORG-ORG-	Not Used
Sharkey's Shootout †	3	090-5030-00T 23-1100 -ORG-ORG-	SAME	090-5030-00T 23-1100 -ORG-ORG-	Not Used
High Roller Casino †	2	090-5020-20T 22-900 -YEL-YEL-	090-5032-00T 23-1080 -YEL-GRN-	Not Used	Not Used
Austin Powers™ †	2	090-5020-30 23-900 -GRN-GRN-	090-5030-00T 23-1100 -ORG-ORG-	Not Used	Not Used
MONOPOLY® †	3	090-5032-00T 22-1080 -YEL-GRN-	SAME	Not Used	090-5062-00T 23-1500 -BLU-BLU-
Playboy †	2	090-5030-00T 23-1100 -ORG-ORG-	SAME	Not Used	Not Used
RollerCoaster Tycoon™ †	4	090-5032-00T 22-1080 -YEL-GRN-	SAME	090-5067-00T 25-1400 -RED-RED-	090-5068-00T 25-1600 -WHT-WHT
The Simpsons™ Pinball Party †	6* (5 with Flipper Bats)	090-5032-00T 22-1080 -YEL-GRN-	SAME	Not Used	090-5030-00T 23-1100 -ORG-ORG-
		* The Homer Head Assembly is affixed to an Up. Rt. Style Flipper (no E.O.S. Switch):		Flippers (Mini-Bats) on 2nd Level Playfield:	
			* 090-5020-20T 22-900 -YEL-YEL-	090-5041-00T 25-1800 -BLU-GRN-	090-5025-00T 24-1570 -See Note-
Terminator® 3: Rise of the Machines™ †	2	090-5032-00T 22-1080 -YEL-GRN-	SAME	Not Used	Not Used
The Lord of the Rings™ †	2	090-5020-20T 22-900 -YEL-YEL-	SAME	Not Used	Not Used
Ripley's Believe It or Not!® †	3	090-5032-00T 22-1080 -YEL-GRN-	SAME	Not Used	090-5067-00T 25-1400 -RED-RED-

† Coil Part N^os ending with a "T" signifies the Diode is on the top of the lug (on the coil-winding side); Coil Part N^os ending with a "B" signifies the Diode is on the bottom of the lugs.



APPENDIX F

Motor Specification (White Star Board System* Only) Table



Game Name	Function	Specifications	Part Number
Apollo 13	Rocket Up/Down Movement	Bowman Motor 24VAC 60Hz 3W 6 RPM CCW	515-6383-00 <i>incl. Connector</i>
	Moon Unit Rotational Orbit	Multi Products Motor 24VAC 50/60Hz 3W 6 RPM CCW	515-6487-00 <i>incl. Connector</i>
	Shaker	Johnson Motor (Vibrator) 10.5VDC 10 AMP 2950 RPM CW	041-5029-00 MOTOR ONLY
Golden Eye	Satellite Left/Right Movement	Bowman Motor 24VAC 60Hz 3W 6 RPM CW	515-6528-00 <i>incl. Connector</i>
Twister	Spinning Disc with Magnet	Multi Products Motor 24VAC (041-5026-00) 50/60Hz 3W 325 RPM CCW	515-6347-00 <i>incl. Connector</i>
	Backbox Fan (Tornado Wind)	Multi Products Motor 24VAC (041-5052-00) 50/60Hz 3W 3600 RPM CW	515-6531-00 <i>incl. Connector</i>
ID4: Independence Day	Alien Head Open/Close Movement	Servo Motor (94322)	041-5045-00 MOTOR ONLY
<i>SPACE JAM (NO MOTOR USED)</i>			
The Star Wars Trilogy - S.E.	X-Wing Left/Right Movement	Bowman Motor 24VAC (041-5058-00) 60Hz 3W 10 RPM CCW	515-6383-01 <i>incl. Connector</i>
The Lost World: Jurassic Park	Snagger & Center Link Lift Up/Down Movement	Multi Products Motor 20VDC (041-5059-03) 9 RPM Non-Directional	515-6715-03 <i>incl. Connector</i>
	Shaker	Johnson Motor (Vibrator) 10.5VDC 10 AMP 2950 RPM CW	041-5029-00 MOTOR ONLY
The X-Files	X-File Cabinet Lift Up/Down Movement	Multi Products Motor 20VDC 9 RPM CCW	041-5057-00 MOTOR ONLY
Starship Troopers	Warrior Bug Forward/Reverse Movement	Haydon Switch & Instrument, Inc. Stepper Motor 12VDC 4.6W (041-5062-00), Series 36000: 1.4"ø (Non-Captive Shaft not included) HSI #36864-12 (Unipolar) Travel per Step: .004 Step Angle: 15°	515-6794-00 <i>incl. Connector</i> Requires 7" Shaft: 530-5503-00
<i>VIPER NIGHT DRIVIN' (NO MOTOR USED)</i>			
Lost In Space	Spinning Disc with Magnet	Multi Products Motor 24VAC (041-5046-00) 50/60Hz 3W 325 RPM CCW	515-6347-00 <i>incl. Connector</i>
Godzilla	Shaker ‡	Multi #3811 0630 Motor (Vibrator) 12VDC 3100 RPM CW (w/DRL PTS) ‡	041-5029-01 MOTOR ONLY
<i>SOUTH PARK (NO MOTOR USED)</i>			
Harley-Davidson® 1st through 3rd Editions	Shaker ‡	Multi #3811 0630 Motor (Vibrator) 12VDC 3100 RPM CW (w/DRL PTS) ‡	041-5029-01 MOTOR ONLY
	Motorcycle Lift Up/Down Movement	Autotrol 24VAC (041-5072-02) 20 RPM CCW	515-7025-00 <i>incl. Connector</i>
Striker Xtreme (NFL)	Goalie (Linebacker) Left to Right Movement	Multi #3590 12VDC (041-5075-00) 60 RPM	515-7071-00 <i>incl. Connector</i>
Sharkey's Shootout	Mystery Ball Rotating Movement	Hankscraft Motor Model-E 24VAC (041-5076-00) 50/60Hz 3W 20 RPM CW	515-7095-00 <i>incl. Connector</i>
High Roller Casino	Roulette Wheel Rotating Movement	Multi Products Motor 20VDC (041-5078-00) 17 RPM CCW	515-7153-00 <i>incl. Connector</i>
	Up/Dn. Ramp in Slot Mach. Lift Up/Down Movement	Haydon Switch & Instrument, Inc. Stepper Motor 12VDC 4.6W (041-5062-00), Series 36000: 1.4"ø (Non-Captive Shaft not included) HSI #36864-12 (Unipolar) Travel per Step: .004 Step Angle: 15°	515-6794-00 <i>incl. Connector</i> Requires Shaft ¾": 530-5503-01
Austin Powers™	Time Machine Rotating Movement	Multi Products Motor 24VAC (041-5079-00) 50/60Hz 20RPM CCW	515-7141-00 <i>incl. Connector</i>
	Laser Beam Left to Right Directional	Autotrol Motor 24VAC (041-5081-00) 50/60Hz 4W 10RPM Bi-Directional	515-7171-00 <i>incl. Connector</i>
	Dr. Evil Target Lift Up/Down Movement	Hankscraft Motor Model-E 24VAC (041-5030-00) 50/60Hz 6RPM CCW	515-5900-00 <i>incl. Connector</i>
Monopoly®	Mini-Flipper (Waterworks) Rotating Movement	Multi Prod. Motor & Gear Box #7000 EX00159A 20VDC 50/60Hz 85RPM CC/CCW	041-5083-00 MOTOR ONLY
Playboy	Triangular Billboard Rotating Movement	Autotrol Motor (BD511 150-1387) 24VAC 50/60Hz 12RPM Bi-Directional	041-5086-02 MOTOR ONLY
	Centerfold Mechanism Open/Close Movement	Multi Products (3680) Motor 12v DC 10/12 RPM CC/CCW	041-5075-04 MOTOR ONLY
	Tease Drop Screen Lift Up/Down Movement	Haydon Switch & Instrument, Inc. Stepper Motor 12VDC 4.6W (041-5062-00), Series 36000: 1.4"ø (Non-Captive Shaft not included) HSI #36864-12 (Unipolar) Travel per Step: .004 Step Angle: 15°	515-6794-00 <i>incl. Connector</i> Requires 7" Shaft: 530-5503-00

‡ Please Note: "01" Shaker Motor is **Not Compatible** with old Shaker Motor 041-5029-00 (Shaker Motor Assy. 515-5893-00). THIS NEW MOTOR CAN ONLY BE USED IN NEW SHAKER MOTOR ASSY. 515-5893-01.

Table continued on the next page.





APPENDIX F

Motor Specification (White Star Board System* & S.A.M. System** Only) Table



Game Name	Function	Specifications	Part Number
ROLLERCOASTER TYCOON™ (NO MOTOR USED)			
THE SIMPSONS™ PINBALL PARTY (NO MOTOR USED)			
Terminator® 3: Rise of the Machines™	Backbox Ball Shooter Up/Down Movement	Multi Products Motor 24VAC (041-5079-01) 21 RPM CW	515-7317-00 <i>incl. Connector</i>
The Lord of the Rings™	Balrog (Motor & Gate) Open/Close Movement	Multi Prod. Motor 20VDC Series 600B (or equiv.) 50/60Hz 10 RPM Bi-Directional	041-5088-01 MOTOR ONLY
RIPLEY'S BELIEVE IT OR NOT!® (NO MOTOR USED)			
Elvis®	Elvis™ Front/Back Movement	Haydon Switch & Instrument, Inc. Stepper Motor 12VDC 10W (041-5089-00), (Non-Captive Shaft not included) HSI #46868-12-002	500-6809-00 <i>incl. Connector</i> Requires 7.25" Shaft: 530-5658-00
	▶▶▶ OPTIONAL ◀◀◀ Shaker	Multi #3811 0630 Motor (Vibrator) 12VDC (041-5029-01) 3100 RPM (w/DRL PTS)	515-5893-01 <i>incl. Connector</i>
The Sopranos™	Bada Bing! Girls x2 Rotating Posts Movement	Autotrol Synchronous Motor 24VAC 4W 50/60Hz 45.7/54.9 RPM Bi-Directional	041-5092-00 <i>w/1" Shaft + 12" Leads</i>
NASCAR® and [NDSE]	Back Panel Rotating (Car) Windmill (Skill Ball Enter)	Multi Products Motor & Gear Box 20VDC Model #8000 (EX-04-073) 10 RPM	041-5093-00 MOTOR ONLY
Grand Prix	Back Panel Rotating (Car) Windmill (Skill Ball Enter)	Multi Products Motor & Gear Box 20VDC Model #8000 (EX-04-073) 10 RPM	041-5093-00 MOTOR ONLY
World Poker Tour™ (WPT) (NO MOTOR USED)			
The Simpsons™ Kooky Carnival	Bart on Skateboard Left/Right Movement	Multi Products Motor with Crank 24VAC (041-5095-01) 50/60Hz 3W 14 RPM	500-6947-01 <i>incl. Connector</i>
	Left & Right Ramps Up/Down Movement	Multi Products Motor 24VAC (041-5048-01) 50/60Hz 3W 15 RPM CCW (Qty. 2 in game)	515-7558-00 <i>incl. Connector</i>
	Shaker <i>(details in SKC Manual, Page 24)</i>	Multi #3811 0630 Motor (Vibrator) 12VDC 3100 RPM (w/DRL PTS)	041-5029-01 MOTOR ONLY
©Disney's Pirates of the Caribbean	Spinning Disk	Multi #3811R 0630 Motor (Vibrator) 12VDC (041-5029-04) 3100 RPM (w/DRL PTS) -04 is RoHS compliant; can substitute with -01 domestic	511-5024-04 <i>incl. Connector</i>
	Pirate Ship Sinking/Raising Movement	Multi Products Motor & Gear Box 24VDC Model #7000-DCM 12 RPM	041-5101-00 MOTOR ONLY
Family Guy™	Stewie Figurine Left & Right Movement	Stepper Motor NPM PF35T-48D4STD 5V RVB (041-5102-00 Reference Only)	511-5043-00 <i>incl. Connector</i>
Spider-Man™	Doc Ock, Sandman & 3-Bank Up/Down Movement	Sync. Motor 24VAC 50/60Hz 3W 12 RPM CW (041-5103-00 Reference Only)	511-5063-00 <i>incl. Connector</i>
	▶▶▶ OPTIONAL ◀◀◀ Shaker Motor Kit 502-5027-00	Multi #3811R 0630 Motor (Vibrator) 12VDC (041-5029-04) 3100 RPM (w/DRL PTS) -04 is RoHS compliant; can substitute with -01 domestic	515-5893-01 <i>incl. Connector</i>



APPENDIX F

Motor Specification Table

The following table only list games that used motors. Part Numbers starting with "515-" will include the Wiring Harness & Connector.

Game Name	Function	Specifications	Part N ^o
ABC Monday Night Football	Goal Post Up/Down Movement	Motor 24v A.C. 60 RPM CW	515-5222-00
Phantom of the Opera	Organ Up/Down Movement	Bowman Motor 24v 60Hz 3W 11 RPM CCW	515-5256-00
Checkpoint	Mag Wheel (in Backbox)	Motor D.C. (KEN)	041-5005-00
	Shaker	Johnson Motor (Vibrator)	041-5002-00
Teenage Mutant Ninja Turtles	Spinning Pizza Ball Deflector	Gear Motor 24v A.C. 325 RPM CW	515-5397-00
Batman	Bar Target Up/Down Movement	Bowman Motor 24v 60Hz 3W 11 RPM CCW	515-5256-00
Star Trek 25th Anniversary	Swinging Target	Bowman Motor 24v 22½ RPM	515-5534-00
	Transporter F/X	Gear Motor 24v A.C. 3½ RPM	500-5421-00
	Cooling Fan (for Transporter F/X)	4½" Motor 12v	041-5014-00
Lethal Weapon 3	Spinning Light	Motor 2½ v A.C. 4000 RPM CCW	041-5017-00
Star Wars	Bar Target Up/Down Movement	Bowman Motor 24v 60hz 3W 11 RPM CCW	515-5256-00
	R2D2 Robot Left/Right Movement	Bowman Motor 24v A.C. 22½ RPM CW	515-5571-00
	Death Star Rotation	Bowman "G" Motor 24v A.C. 60Hz 6 RPM CW	515-5570-00
Rocky & Bullwinkle & Friends	Nell Log "Cutting Blade" Forward/Back Movement	Autotrol Model E Motor 24v 60hz 4W 3 RPM CCW	041-5023-00
Jurassic Park	T-Rex Left/Right Movement	Multi Motor 5v D.C.	041-5025-00
	T-Rex Up/Down Movement	Bowman Motor 24v 11 RPM CW	041-5026-00
	Shaker	Johnson Motor (Vibrator)	041-5002-00
Last Action Hero	Crane Left/Right Movement	Multi Products Motor 12v D.C. #3312 OSC	041-5027-00
	Shaker	Johnson Motor (Vibrator) 10.5v D.C. 10 AMP 2950 RPM CW	041-5029-00
Tales from the Crypt	Tombstone Up/Down Movement	Bowman Motor 24v A.C. 6 RPM CCW	515-5900-00
	Shaker	Johnson Motor (Vibrator) 10.5v D.C. 10 AMP 2950 RPM CW	041-5029-00
The Who's Tommy	Mirror Up/Down Movement	Bowman Motor 24v A.C. 6 RPM CCW	515-5900-00
	Flipper Blinders	Servo Motor (94102)	041-5032-00
	Spinning Airplane Propellers	Motor D.C.	041-5033-00
WWF Royal Rumble	Shaker	Johnson Motor (Vibrator) 10.5v D.C. 10 AMP 2950 RPM CW	041-5029-00
Maverick, The Movie	Turning Paddle Wheel	Motor 24v A.C. 10 RPM	041-5036-00
Mary Shelley's Frankenstein	Creature Head Left/Right Movement	Servo Motor (94102)	041-5032-00
Batman Forever	Cannon Left/Right Movement	Bowman Motor 24v A.C. 60Hz 3W 6 RPM CCW	515-6383-00

APPENDIX G

Part Number Prefix Classification Codes

I. Electrical Source, Energy & Signal Converters

- 010- Transformers
- 031- Speakers
- 090- Solenoids (Coils)
- 150- Filters, Outlets, Varistors, Thermistors
- 200- Fuses

II. Conductors, Connectors & Insulators

- 034- Line Cords
- 036- Cable Assemblies & Wiring Harnesses
- 041- Motors
- 045- Connectors (All Types)
- 055- Lugs (M/F), Pins (M/F), Discs, Ring Terminals, Terminal Strips, etc.
- 060- Polarizing Keys and Conn. Covers
- 077- Lamp Sockets

III. Circuits & Circuit Elements

- 100- ICs
- 110- Transistors
- 112- Diodes (All Types including LEDs & Modules)
- 121- Resistors
- 123- Resistors (Variable & Adjustable)
- 124- Regulators & Bridge Rectifiers
- 125- Capacitors (Radial Lytics & Ferrites)
- 126- Piezo Crystal
- 127- Heatsinks
- 130- Capacitors (Tectates & Ceramics)
- 140- Oscillators (Clocks/Crystals)
- 165- Light Bulbs
- 180- Switches
- 181- Switch Membranes (Pads) & Piezo Sensors
- 190- Relays
- 960- EPROM (*Raw Part*)
- 965- EPROM (*Programmed Part*)

IV. Bolts, Screws, Nuts, Washers & Nails

- 231- Bolts
- 232- Screws (Pan Head)
- 234- Screws (HWH)
- 237- Screws (Misc.)
- 240- Nuts (Misc.)
- 242- Washers (Flat, Round)
- 244- Washers (Split Lock)
- 245- Nyloners
- 246- Washers (Lockers, External Tooth)
- 281- Nails

V. Mechanical Components

- 249- Rivets
- 251- Pins (Dowel), Finishing Nails, Hairpins, Spring Pins and Clevis Pins
- 254- Stand-Offs, Spacers and Shims
- 260- Steel Ball (All Types Steel, Glowing, Delrin, etc.)
- 265- Springs (Extension)
- 266- Springs (Compression)
- 267- Springs (Torsion)
- 269- Springs (Washers - Belleville, Wave)
- 270- Retaining Rings
- 280- Grommets, Bushings and Nyloners
- 283- Bearings

VI. Handles, Locks, Catches, Latches, Keys

- 355- Handles, Locks, Catches, Latches and Keys

VII. Fabricated Parts

- 390- Hinges
- 501- Coin Doors
- 515- Sub-Assemblies
- 520- Printed Circuit Boards (PCBs)
- 522- Display Glass
- 525- Wood Parts
- 530- Screw Machined Parts
- 535- Fabricated Parts
- 545- Molded (Extruded) Plastic and Rubber Parts (Rings, Sleeves, etc.)
- 550- Molded (Inserts)

VIII. In-House Assemblies

- 500- End Product (Systems and Models)
- 502- Kits (Created In-House)
- 505- Cabinets (complete)
- 510- Riveted Sub-Assemblies (In-House)
- 511- Sub-Assemblies (In-House)
- 515- Sub-Assemblies*

*2 or more 515-'s but still a sub-assembly.

IX. Bulk Materials

- 600- Braided Wire & Ground Straps
- 601- Stranded Wire
- 602- Ribbon Cable
- 604- Telephone Line Cord
- 605- Sleeving (Shrink Tubing)
- 625- Velcro (non-adhesive)
- 626- Foam Rubber, Foam Pads, Rubber Bumpers (Blue Pads), Tape (All Types) Velcro (adhesive) and String / Rope

















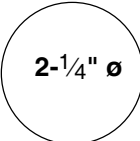
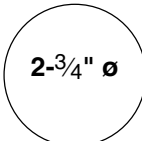
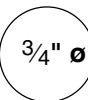
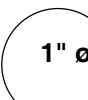
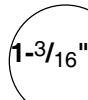
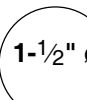
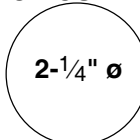
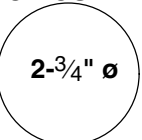

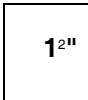
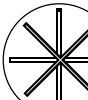
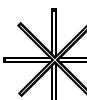
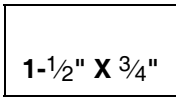
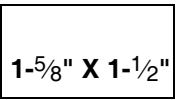
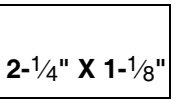
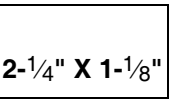
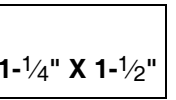
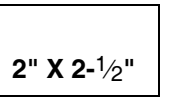
X. Miscellaneous

- 000- Tools (*see also 777-*) and Supplies
- 040- Clamps, Ties & Clips
- 042- Pulleys
- 091- Coin Mechs
- 205- Fuse Holders
- 631- Staples
- 660- Glass (Playfield, Backglass, etc.)
- 675- Cleaners
- 705- Packing & Shipping Items
- 755- Instruction, Coin Cards, Ins. Sheets
- 756- Information Sheets, Service Bulletins, Instruction Sheets in Kits and Templates
- 777- Tools (Wrenches and Drivers)
- 780- Manuals
- 802- Decal Kits (comprised of 820's)
- 820- Decals, Mylar and Labels (Sheets/Sets)
- 803- Plastic Kits (comprised of 830's)
- 830- Plastic Pieces (Butyrate Sheets/Sets)
- 880- Toys, Models, Figurines, etc.
- 900- Game Posters

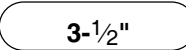
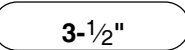

APPENDIX H

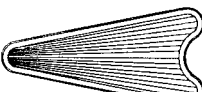
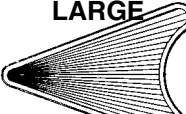
Playfield Inserts (Plastic Light Covers)

Patterns: STARBURST  STIPPLE 	STARBURST CIRCULAR  550-5000-XX	STARBURST CIRCULAR  550-5001-XX	STARBURST CIRCULAR  550-5002-XX	STARBURST CIRCULAR  550-5003-XX	STARBURST CIRCULAR  550-5004-XX
STARBUST CIRCULAR  550-5005-XX	STARBUST CIRCULAR  550-5006-XX	PLAIN CIRCULAR  550-5007-XX	PLAIN CIRCULAR  550-5008-XX	PLAIN CIRCULAR  550-5009-XX	PLAIN CIRCULAR  550-5010-XX
PLAIN CIRCULAR  550-5011-XX	PLAIN CIRCULAR  550-5012-XX	STIPPLE CIRCULAR  550-5048-XX	STIPPLE 1" SQUARE  550-5019-XX	ROLLOVER BUTTON BASE  550-5026-XX	WHITE STAR (only in white)  545-5015-00
STIPPLE RECTANGULAR  550-5018-XX	STIPPLE RECTANGULAR  550-5051-XX	STARBUST RECTANGULAR  550-5044-XX	PLAIN RECTANGULAR  550-5049-XX	PLAIN RECTANGULAR  550-5050-XX	PLAIN RECTANGULAR  550-5063-XX
STARBUST MINI SHIELD  550-5024-XX	STARBUST LARGE SHIELD  550-5025-XX	MINI HOT DOG  550-5020-XX	BEVEL HOT DOG  550-5021-XX	PLAIN HOT DOG  550-5022-XX	BANANA  550-5023-XX
STARBUST ARROW-SMALL  550-5013-XX	STARBUST ARROW-LARGE  550-5070-XX	STARBUST ARROW-HEAD SMALL  550-5014-XX	STARBUST ARROW-HEAD LARGE  550-5015-XX	STARBUST BULLET  550-5016-XX	STARBUST TRIANGLE  550-5017-XX

Note: The shapes and sizes shown above are not to scale. Some shapes may no longer be available in every color.

Instructions: Parts which may come in various colors (i.e. targets, some posts, playfield inserts, etc.) end in a 2-digit number which correspond to the color of that part. The "-XX" in part number which may come in various colors should be replaced with the desired 2-Digit number corresponding to the color desired below. *Not all colors may be available.*

PLASTIC PART COLOR CHART											
Nº	Color	Nº	Color	Nº	Color	Nº	Color	Nº	Color	Nº	Color
-00	Black or Solid Clear	-03	Amber	-06	Yellow	-09	Purple	-12	Fluor. Blue	-15	Luminescent
-01	Clear	-04	Green	-07	Orange	-10	Fluor. Orange	-13	Teal Green	-16	Gold
-02	Red	-05	Blue	-08	White	-11	Fluor. Green	-14	Gray	-17	Trans. Brown

APPENDIX I

Stand-Up Targets

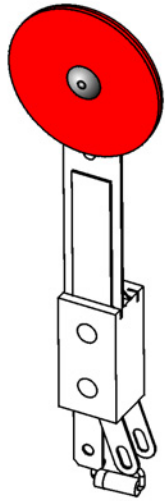

112-5003-00
Switch Diode, 1N4004
(all Stand-Up Targets)

515-5966-XX
1" ROUND STAND-UP
SWITCH & TARGET
RIVETED ASSEMBLY*

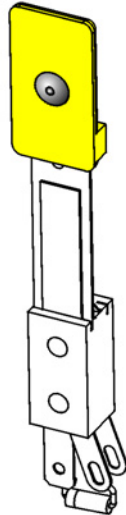

STANDARD
515-5967-XX or **ANTI-LOFT**
515-7581-XX
1" X 1/2" NARROW STAND-UP
SWITCH & TARGET
RIVETED ASSEMBLY*

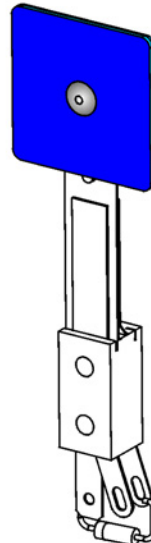

515-5162-XX
1" X 1" SQUARE STAND-UP
SWITCH & TARGET
RIVETED ASSEMBLY*

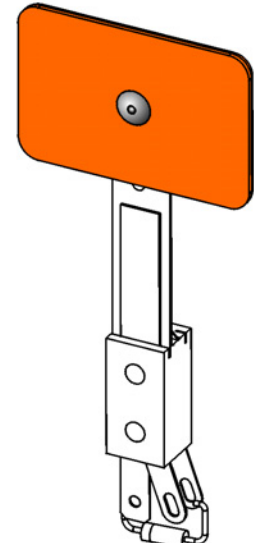

515-6027-XX
1" X 1-1/2" RECTANGLE STAND-UP
SWITCH & TARGET
RIVETED ASSEMBLY*

**Note: Does not include the Switch Back Plate, Mounting Bracket or screws.*

To include the Switch Back Plate, Foam Pad, and Switch Mounting Bracket assembled, use the follow assembly part numbers (replace the -XX with 2-digit number from chart):

500-5835-XX : 1" ROUND TARGET 500-5857-XX : 1" X 1/2" NARROW TARGET 500-5232-XX : 1" X 1" SQUARE TARGET 500-5321-XX : 1" X 1-1/2" RECT. TARGET

REAR VIEW 515-5967-06 SHOWN

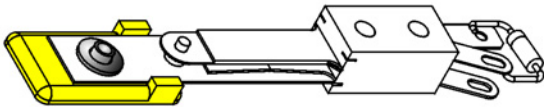

SHOWN BELOW : 500-5857-06
1" X 1/2" NARROW STAND-UP
TARGET ASSEMBLY COMPLETE

626-5029-00
Foam Pad, Square
.44" X .44" X .125" Thick (Self-Adhesive)**

** Note:
Use with all Switch
& Targets THIS page
except for 515-7581-XX

535-6896-00
Bracket, Switch
Mounting
(all targets THIS page)

237-5976-05
#6-32 X 3/4" SHWH Sc.
(all targets THIS page)

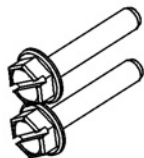

515-5967-XX
1" X 1/2" NARROW
STAND-UP (STANDARD)
SWITCH & TARGET
RIVETED ASSEMBLY*

535-6452-00
Switch Back Plate**

535-6896-00
Bracket, Switch
Mounting
(all targets THIS page)

237-5976-05
#6-32 X 3/4" SHWH Sc.
(all targets THIS page)

-XX REPLACE WITH 2-DIGIT FOR COLOR:

- 00 Black
- 01 Clear
- 02 Red
- 03 Amber
- 04 Green
- 05 Blue
- 06 Yellow
- 07 Orange
- 08 White
- 09 Purple
- 10 Fluor. Orange
- 11 Fluor. Green
- 12 Fluor. Blue
- 13 Teal Green
- 14 Gray
- 15 Luminescent
- 16 Gold

Note: Not all colors available.

SHOWN BELOW : 500-6985-04

1" X 1/2" NARROW ANTI-LOFT
STAND-UP TARGET
ASSEMBLY COMPLETE

626-5069-00
Foam Pad, Rectangle
.6" X .4" X .25" Thick (Self-Adhesive) ‡

535-9823-01
Switch Back
Plate ‡

‡ Note: Use only with
515-7581-XX Switch &
Target Assembly unless
otherwise noted.

515-7581-XX
1" X 1/2" NARROW
STAND-UP TALL
SWITCH & TARGET
RIVETED ASSEMBLY*

ORDERING NOTE: 515-7581-XX (500-6985-XX)

differences from 515-5967-XX (500-5857-XX) are:

1. Switch & Target Taller (Target sits higher over P/F)
2. Switch Back Plate differs (bend, shape & tab)
3. Foam Pad differs (thicker, taller, different type foam)

**Note: Does not include the Switch Back Plate, Mounting Bracket or screws.*

APPENDIX I

Modular Stand-Up Targets

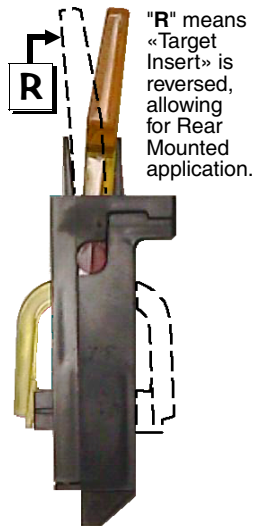

"R" means «Target Insert» is reversed, allowing for Rear Mounted application.



Take Note:

- Items A-E come in various colors. These targets may not be available in every color. The "-XX" in should be replaced with the desired 2-Digit number for the color desired as described in the Color Chart below. As of print date, the following colors were used :
 -01 Clear (A, D); -02 Red (A, B, C, D, E); -03 Amber (D, E);
 -04 Green (A, B); -05 Blue (C); -06 Yellow (A, C),
 -09 Purple (B, D); -11 Fluorescent Green (A, B, D)
- For location(s) and type of Stand-Up Targets used, if any, see Section 4, Chapter 1, Parts Identification & Location.

-XX REPLACE WITH 2-DIGIT FOR COLOR:

- 00 Black
 - 01 Clear
 - 02 Red
 - 03 Amber
 - 04 Green
 - 05 Blue
 - 06 Yellow
 - 07 Orange
 - 08 White
 - 09 Purple
 - 10 Fluor. Orange
 - 11 Fluor. Green
 - 12 Fluor. Blue
 - 13 Teal Green
 - 14 Gray
 - 15 Luminescent
 - 16 Gold
- Note: Not all colors available.*

Nr.	STAND-UP TARGET PARTS	SPI PART Nr.
A	Modular Stand-Up Target Narrow Assy.	500-6138-XX
	Stand-Up Target Narrow (Insert)	545-6138-XX
B	Modular Stand-Up Target Square Assy.	500-6139-XX
	Stand-Up Target Square (Insert)	545-6139-XX
C	Modular Stand-Up Target Rectangle Assy.	500-6228-XX
	Stand-Up Target Rectangle (Insert)	545-6228-XX
D	Modular Stand-Up Target Round Assy.	500-6075-XX
	Stand-Up Target Round (Insert)	545-6075-XX
E	Mod. Stand-Up Target 1" Spherical Assy.	500-6189-XX
	Stand-Up Target 1" Spherical (Insert)	545-6189-XX

To Replace the « Target Insert » or change Target Orientation :

Items A-E Note: For the Target Assembly use the "500-" SPI Part Number(s) shown in the Parts Table below. To receive the Target Assembly with the « Target Insert » « Reversed » simply add a "R" at the end of the Part Number. See Side View picture left to compare (dashed line shows target reversed). For just the «Target Insert» use the "545-" SPI Part Number.



To reverse it yourself or to just change the insert:

- With a small flat head screwdriver, push into the small tab at the bottom of the target front and give a slight twist motion to "pop" the two halves.

- Push the Target Insert bottom in at the same time while you slide the top (front) part up, then let go of the insert as the two halves come apart.

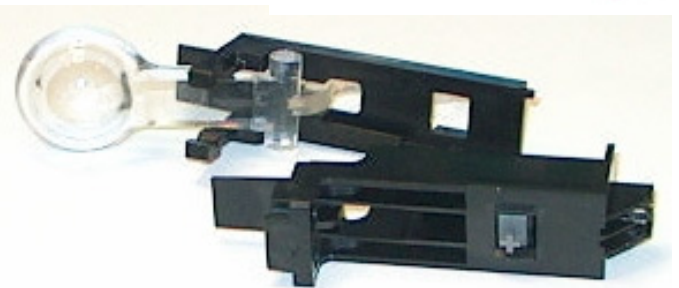

- Replace target or reinsert it into the other size while sliding the two halves back together.

Note: If you were reversing the orientation, don't forget to also turn the Switch Actuator PCB 180°. Test Switch.

APPENDIX J

Coin Cards (USA & International Pricing Defaults) ▶ For Yellow Stock add -Y to the Part Number

If more than one Pricing Scheme is available for countries listed, the **F.** listed beside the option, denotes the Factory Default Setting.
FOR VIEWS OF THE LATEST or OPTIONAL USA, INTERNATIONAL / EURO AND CUSTOM COIN CARDS, VISIT OUR WEBSITE.
 Not Shown USA 755-5400-10 Tournament Option \$2 = X1; 755-5400-11 Tournament Option \$1.50 = X1

USA 10 F. 755-5400-11 Front		USA 10 755-5400-11 Back		USA 2-7 or CANADA 755-5400-02 Front		FOR CUSTOM PRICING † 755-5400-01, -02 or -04 Back		USA 3 with ToPS™ 755-5400-03 or -09 Front		USA 5 with ToPS™ 755-5400-03 Back / -08 Front	
AUSTRALIA 1 F. 755-5406-00 Front		AUSTRALIA 2 755-5406-00 Back		CROATIA 755-5410-00 Front		FOR CUSTOM PRICING † 755-5410-00 Back		DENMARK 1 F. 755-5402-00 Front		DENMARK 2 755-5402-00 Back	
JAPAN 1 755-5408-01 Front		JAPAN 2 F. 755-5408-01 Back		MIDDLE EAST 755-5400-06 Front		ANY COUNTRY CAN USE 755-5400-06 Back		NEW ZEALAND 1 F. 755-5406-00 Back		NEW ZEALAND 2 755-5406-00 Front	
NORWAY 1 F. 755-5403-01 Front		NORWAY 2 755-5403-01 Back		RUSSIA F. 755-5411-00 Front		RUSSIA (ALTERNATE) 755-5411-00 Back		SOUTH AFRICA 755-5409-01 Front		FOR CUSTOM PRICING † 755-5409-01 Back	
SWEDEN 1 F. 755-5404-00 Front		SWEDEN 2 755-5404-00 Back		SWITZERLAND 1 F. 755-5405-00 Front		SWITZERLAND 2 755-5405-00 Back		TAIWAN 755-5412-00 Front		FOR CUSTOM PRICING † 755-5412-00 Back	
UK 1 755-5407-00 Front		UK 3 755-5407-00 Back		UK 5 F. 755-5407-01 Front		FOR CUSTOM PRICING † 755-5407-01 Back		Appendix J Notes: 1. Coin Card on Game is determined by original shipping country destination. 2. Optional Coin Card(s), are available via your distributor or via free download @ www.sternpinball.com/coinagecards.shtml . Older style Coin Cards (foreign or domestic) not available on our website or no longer available through your distributor, are obsolete. 3. Coin Cards which have a Blank Backside can be used for †Custom Pricing.			

Not Shown EURO 755-5401-20 Tournament Custom (can fill in your own pricing).

EURO 1 755-5401-01 1-Side Only		EURO 2 755-5401-02 1-Side Only		EURO 3 755-5401-03 1-Side Only		EURO 4 755-5401-04 1-Side Only		EURO 5 755-5401-05 1-Side Only		EURO 6 755-5401-06 1-Side Only	
EURO 7 755-5401-07 1-Side Only		EURO 8 755-5401-08 1-Side Only		EURO 9 755-5401-09 1-Side Only		EURO 10 755-5401-10 1-Side Only		EURO 11 755-5401-11 1-Side Only		EURO 12 755-5401-12 1-Side Only	

▶ EURO FACTORY DEFAULT SUMMARY TABLE ◀

EURO 1	EURO 2	EURO 3	EURO 4	EURO 5	EURO 6	EURO 7	EURO 8	EURO 9	EURO 10	EURO 11	EURO 12
BELGIUM ITALY 1 PORTUGAL	GERMANY 2	NETHERLANDS SPAIN			GREECE		FINLAND	AUSTRIA	FRANCE		

Section 3, Chapter 4, GO TO ADJUSTMENTS MENU, Adj. 18, Game Pricing, USA & International (non-Euro) and Euro 1-12 Summary & International (Euro) Standard Pricing Select Tables, summarizes Standard or Custom Pricing Schemes & the Dip Switch Setting required.





APPENDIX A



Pinball Game Firmware (White Star Board System* Only) Table

See website for the latest International Code or Updated USA version / checksums

ROM	Chip Size	Program Part N ^o	USA ver. & Check Sum	Bd. Loc.	Raw Part N ^o
Apollo 13 (Note 1)					
Game ROM (1M)	965-0208-00	A5.01	\$09FF	U210	960-5009-00
Sound (512K)	965-0212-00	1.00	\$5244	U7	960-7001-02
Display (4M)	965-0217-42	A5.00	\$B92B	ROM 0	960-5015-01
Voice 1 (4M)	965-0209-00	1.00	\$7FC7	U17	n/a (masked)
Voice 2 (4M)	965-0210-00	1.00	\$8E55	U21	n/a (masked)
Voice 3 (4M)	965-0211-00	1.00	\$08EE	U36	n/a (masked)
Golden Eye (Note 1)					
Game ROM (1M)	965-0214-42	A4.04	\$3FFF	U210	960-5009-00
Sound (512K)	965-0217-42	1.00	\$D615	U7	960-7001-02
Display (4M)	965-0218-42	A4.00	\$E6ED	ROM 0	960-5015-01
Voice 1 (4M)	965-0215-42	1.00	\$3E32	U17	n/a (masked)
Voice 2 (4M)	965-0216-42	1.00	\$71F0	U21	n/a (masked)
Twister (Note 2)					
Game ROM (1M)	965-0219-41	A4.05	\$E9FF	U210	960-5009-00
Sound (512K)	965-0221-41	1.00	\$1FFF	U7	960-7001-02
Display (4M)	965-0222-41	A4.00	\$FD01	ROM 0	960-5015-01
Voice 1 (4M)	965-0220-41	1.00	\$3650	U17	960-5015-01
Voice 2 (4M)	965-0223-41	1.00	\$9300	U21	960-5015-01
ID4: Independence Day (Note 2)					
Game ROM (1M)	965-0224-45	A2.02	\$9CFF	U210	960-5009-00
Sound (512K)	965-0227-45	1.00	\$222B	U7	960-7001-02
Display (4M)	965-0228-45	A2.00	\$AB7	ROM 0	960-5015-01
Voice 1 (4M)	965-0225-45	1.00	\$3AF1	U17	960-5015-01
Voice 2 (4M)	965-0226-45	1.00	\$206E	U21	960-5015-01
Space Jam (Note 2)					
Game ROM (1M)	965-0229-43	A3.00	\$E6FF	U210	960-5009-00
Sound (512K)	965-0233-43	1.00	\$F1E7	U7	960-7001-02
Display (4M)	965-0234-43	A3.00	\$0057	ROM 0	960-5015-01
Voice 1 (4M)	965-0230-43	1.00	\$DBA8	U17	960-5015-01
Voice 2 (4M)	965-0231-43	1.00	\$DDF1	U21	960-5015-01
Voice 3 (4M)	965-0232-43	1.00	\$F32A	U36	960-5015-01
The Star Wars Trilogy - Special Edition (S.E.) (Note 2)					
Game ROM (1M)	965-0235-56	A4.03	\$5EFF	U210	960-5009-00
Sound (512K)	965-0238-56	1.00	\$4A7D	U7	960-7001-02
Display (4M)	965-0239-56	A4.00	\$8817	ROM 0	960-5015-01
Voice 1 (4M)	965-0236-56	1.00	\$E66B	U17	960-5015-01
Voice 2 (4M)	965-0237-56	1.00	\$8F54	U21	960-5015-01
The Lost World: Jurassic Park (Note 2)					
Game ROM (1M)	965-0240-53	A2.02	\$C8FF	U210	960-5009-00
Sound (512K)	965-0243-53	1.00	\$A35B	U7	960-7001-02
Display (4M)	965-0244-53	A2.01	\$7F46	ROM 0	960-5015-01
Voice 1 (4M)	965-0241-53	1.00	\$1D27	U17	960-5015-01
Voice 2 (4M)	965-0242-53	1.00	\$8DA4	U21	960-5015-01
The X-Files (Note 2)					
Game ROM (1M)	965-0245-46	A3.03	\$A2FF	U210	960-5009-00
Sound (512K)	965-0248-46	1.00	\$65A8	U7	960-7001-02
Display (4M)	965-0249-46	A3.00	\$66D0	ROM 0	960-5015-01
Voice 1 (4M)	965-0246-46	1.00	\$349D	U17	960-5015-01
Voice 2 (4M)	965-0247-46	1.00	\$629C	U21	960-5015-01
Starship Troopers (Note 3)					
Game ROM (1M)	965-0250-59	A2.00	\$85FF	U210	960-5009-00
Sound (512K)	965-0253-59	1.00	\$64B2	U7	960-7001-02
Display (4M)	965-0254-59	A2.00	\$E77B	ROM 0	960-5015-01
Voice 1 (4M)	965-0251-59	1.00	\$152A	U17	960-5015-01
Voice 2 (4M)	965-0252-59	1.00	\$0291	U21	960-5015-01
Voice 3 (4M)	965-0255-59	1.00	\$95A7	U36	960-5015-01
Viper Night Drivin' (Note 4)					
Game ROM (1M)	965-0266-35	A2.01	\$C5FF	U210	960-5009-00
Sound (512K)	965-0271-35	1.00	\$4DF8	U7	960-7001-02
Display (4M)	965-0272-35	A2.01	\$C17D	ROM 0	960-5015-01
Voice 1 (4M)	965-0267-35	1.00	\$9018	U17	960-5015-01
Voice 2 (4M)	965-0268-35	1.00	\$2157	U21	960-5015-01
Voice 3 (4M)	965-0269-35	1.00	\$B5A6	U36	960-5015-01
Voice 4 (4M)	965-0270-35	1.00	\$D01E	U37	960-5015-01
Lost In Space (Note 4)					
Game ROM (1M)	965-0282-60	A1.01	\$B2FF	U210	960-5009-00
Sound (512K)	965-0287-60	1.00	\$A6AF	U7	960-7001-02
Display (4M)	965-0288-60	A1.02	\$32AB	ROM 0	960-5015-01
Voice 1 (4M)	965-0283-60	1.00	\$4391	U17	960-5015-01
Voice 2 (4M)	965-0284-60	1.00	\$8215	U21	960-5015-01
Voice 3 (4M)	965-0285-60	1.00	\$5B32	U36	960-5015-01
Voice 4 (4M)	965-0286-60	1.00	\$8971	U37	960-5015-01
Godzilla (Note 4)					
Game ROM (1M)	965-0289-40	A2.05	\$B1FF	U210	960-5009-00
Sound (512K)	965-0294-40	1.00	\$0CC9	U7	960-7001-02
Display (4M)	965-0290-40	A2.00	\$C929	ROM 0	960-5015-01
Voice 1 (4M)	965-0290-40	1.00	\$0D75	U17	960-5015-01
Voice 2 (4M)	965-0291-40	1.00	\$CCCF	U21	960-5015-01
Voice 3 (4M)	965-0292-40	1.00	\$227F	U36	960-5015-01
Voice 4 (4M)	965-0293-40	1.00	\$DB69	U37	960-5015-01
South Park (Notes 4, 5)					
Game ROM (1M)	965-0301-71	A1.03	\$58FF	U210	960-5009-00
Sound (512K)	965-0306-71	1.00	\$1286	U7	960-7001-02
Display (4M)	965-0307-71	A1.01	\$166F	ROM 0	960-5015-01
Voice 1 (8M)	965-0302-71	1.00	\$7BF8	U17	960-5016-00
Voice 2 (8M)	965-0303-71	1.00	\$9CCC	U21	960-5016-00
Voice 3 (8M)	965-0304-71	1.00	\$ADD9	U36	960-5016-00
Voice 4 (8M)	965-0305-71	1.00	\$6559	U37	960-5016-00

ROM	Chip Size	Program Part N ^o	USA ver. & Check Sum	Bd. Loc.	Raw Part N ^o
Harley-Davidson® (Notes 4, 5, 6) Original (1999-2001)					
Game ROM (1M)	965-0319-67	A1.03	\$3EFF	U210	960-5009-00
Sound (512K)	965-0320-67	1.00	\$F4FF	U7	960-7001-02
Display (4M)	965-0321-67	A1.04	\$FC7C	ROM 0	960-5015-01
Voice 1 (8M)	965-0322-67	1.00	\$CD26	U17	960-5016-00
Voice 2 (8M)	965-0323-67	1.00	\$3936	U21	960-5016-00
Voice 3 (8M)	965-0324-67	1.00	\$FB72	U36	960-5016-00
Voice 4 (4M)	965-0325-67	1.00	\$6100	U37	960-5015-01
► Harley-Davidson® (Notes 4, 5, 6, 8) 2nd Edition (2002-2003)					
Game ROM (1M)	965-0319-67A	A1.08	\$23FF	U210	960-5009-00
Display (4M)	965-0321-67A	A1.05	\$B594	ROM 0	960-5015-01
► Harley-Davidson® (Notes 4, 5, 6, 8) 3rd Edition (2004)					
Game ROM (1M)	965-0319-87	A4.00	\$1CFF	U210	960-5009-00
Display (4M)	965-0321-87	A4.00	\$F4FF	U5	960-5015-01
Striker Xtreme (Notes 4, 5)					
Game ROM (1M)	965-0326-68	A1.03	\$E4FF	U210	960-5009-00
Sound (512K)	965-0327-68	1.00	\$3BCA	U7	960-7001-02
Display (4M)	965-0328-68	A1.03	\$1957	ROM 0	960-5015-01
Voice 1 (8M)	965-0329-68	1.00	\$482A	U17	960-5016-00
Voice 2 (8M)	965-0330-68	1.00	\$7312	U21	960-5016-00
Voice 3 (8M)	965-0331-68	1.00	\$DE2F	U36	960-5016-00
Voice 4 (8M)	965-0332-68	1.00	\$C508	U37	960-5016-00
NFL (Notes 4, 5) Not on CD-R or Website: Code through Distributor Only.					
Game ROM (1M)	965-0339-73	A1.00	\$D2FF	U210	960-5009-00
Sound (512K)	965-0340-73	1.00	U7	960-7001-02	
Display (4M)	965-0341-73	A1.01	\$845A	ROM 0	960-5015-01
Voice 1 (8M)	965-0342-73	1.00	U17	960-5016-00	
Voice 2 (8M)	965-0343-73	1.00	U21	960-5016-00	
Voice 3 (8M)	965-0344-73	1.00	U36	960-5016-00	
Voice 4 (8M)	965-0345-73	1.00	U37	960-5016-00	
Sharkey's Shootout (Notes 4, 5)					
Game ROM (1M)	965-0333-72	A2.11	\$49FF	U210	960-5009-00
Sound (512K)	965-0333-72	1.01	\$9796	U7	960-7001-02
Display (4M)	965-0335-72	A2.01	\$6C33	ROM 0	960-5015-01
Voice 1 (8M)	965-0336-72	1.00	\$58EA	U17	960-5016-00
Voice 2 (8M)	965-0337-72	1.00	\$272B	U21	960-5016-00
Voice 3 (8M)	965-0338-72	1.00	\$41AE	U36	960-5016-00
High Roller Casino (Notes 4, 5)					
Game ROM (1M)	965-0346-65	A3.00	\$90FF	U210	960-5009-00
Sound (512K)	965-0347-65	1.00	\$581C	U7	960-7001-02
Display (4M)	965-0348-65	A3.00	\$74B3	ROM 0	960-5015-01
Voice 1 (8M)	965-0349-65	1.00	\$E12D	U17	960-5016-00
Voice 2 (8M)	965-0350-65	1.00	\$38F4	U21	960-5016-00
Voice 3 (8M)	965-0351-65	1.00	\$1B54	U36	960-5016-00
Voice 4 (8M)	965-0352-65	1.00	\$D720	U37	960-5016-00
Austin Powers™ (Notes 4, 5)					
Game ROM (1M)	965-0353-74	A3.02	\$5DFF	U210	960-5009-00
Sound (512K)	965-0354-74	1.00	\$D47B	U7	960-7001-02
Display (4M)	965-0355-74	A3.00	\$6A3A	ROM 0	960-5015-01
Voice 1 (8M)	965-0356-74	1.00	\$D2B9	U17	960-5016-00
Voice 2 (8M)	965-0357-74	1.00	\$9E75	U21	960-5016-00
Voice 3 (8M)	965-0358-74	1.00	\$51F3	U36	960-5016-00
Voice 4 (8M)	965-0359-74	1.00	\$0AE5	U37	960-5016-00
MONOPOLY® (Notes 4, 5)					
Game ROM (1M)	965-0360-75	A3.20	\$07FF	U210	960-5009-00
Sound (512K)	965-0361-75	1.00	\$8C18	U7	960-7001-02
Display (4M)	965-0362-75	A3.01	\$A381	ROM 0	960-5015-01
Voice 1 (8M)	965-0363-75	1.00	\$35E6	U17	960-5016-00
Voice 2 (8M)	965-0364-75	1.00	\$B35A	U21	960-5016-00
Voice 3 (8M)	965-0365-75	1.00	\$8A9F	U36	960-5016-00
Playboy (Notes 4, 5, 7)					
Game ROM (1M)	965-0367-76	A5.00	\$7DFF	U210	960-5009-00
Sound (512K)	965-0368-76	1.02	\$E7C2	U7	960-7001-02
Display (4M)	965-0369-76	A5.00	\$A5FF	ROM 0	960-5015-01
Voice 1 (8M)	965-0370-76	1.00	\$9ABE	U17	960-5016-00
Voice 2 (8M)	965-0371-76	1.00	\$9F34	U21	960-5016-00
Voice 3 (8M)	965-0372-76	1.00	\$374B	U36	960-5016-00
Voice 4 (8M)	965-0373-76	1.00	\$237A	U37	960-5016-00
RollerCoaster Tycoon™ (Notes 4, 5, 7)					
Sound (512K)	965-0374-78	1.00	\$F663	U7	960-7001-02
Game ROM (1M)	965-0375-78	A7.02	\$5E5F	U210	960-5009-00
Voice 1 (8M)	965-0377-78	1.00	\$3C4A	U17	960-5016-00
Voice 2 (8M)	965-0378-78	1.00	\$057A	U21	960-5016-00
Voice 3 (8M)	965-0379-78				



APPENDIX A

Pinball Game Firmware (White Star Board System* & S.A.M. System** Only) Table



See website for the latest International Code or Updated USA version / checksums

ROM	Chip Size	Program Part N ^o	USA Ver. & Check Sum	Bd. Loc.	Raw Part N ^o
Ripley's Believe It or Not!® (Notes 7, 8)					
Sound	(512K)	965-0408-81	1.00 \$D93D	U7	960-7001-02
Game ROM	(1M)	965-0409-81	A3.20 \$43FF	U210	960-5009-00
Voice 1	(8M)	965-0410-81	1.00 \$067B	U17	960-5016-00
Voice 2	(8M)	965-0411-81	1.00 \$C8E8	U21	960-5016-00
Voice 3	(8M)	965-0412-81	1.00 \$64C2	U36	960-5016-00
Voice 4	(8M)	965-0413-81	1.00 \$5341	U37	960-5016-00
Display	(4M)	965-0414-81	A3.00 \$DE4B	U5 DC PCB	960-5015-01

Elvis® (Notes 7, 8)					
Sound	(512K)	965-0415-84	1.00 \$8CD2	U7	960-7001-02
Game ROM	(1M)	965-0416-84	A5.00 \$50FF	U210	960-5009-00
Voice 1	(8M)	965-0417-84	1.00 \$538D	U17	960-5016-00
Voice 2	(8M)	965-0418-84	1.00 \$8BCD	U21	960-5016-00
Voice 3	(8M)	965-0419-84	1.00 \$60F8	U36	960-5016-00
Voice 4	(8M)	965-0420-84	1.00 \$14D8	U37	960-5016-00
Display	(4M)	965-0421-84	A5.00 \$A1F6	U5 DC PCB	960-5015-01

The SopranosSM (Notes 7, 8)					
Sound	(512K)	965-0422-85	4.00 \$9B5A	U7	960-7001-02
Game ROM	(1M)	965-0423-85	A5.00 \$5BFF	U210	960-5009-00
Voice 1	(8M)	965-0424-85	3.00 \$F01E	U17	960-5016-00
Voice 2	(8M)	965-0425-85	1.04 \$C14C	U21	960-5016-00
Voice 3	(8M)	965-0426-85	1.04 \$47A3	U36	960-5016-00
Voice 4	(8M)	965-0427-85	1.04 \$ADCD	U37	960-5016-00
Display	(4M)	965-0428-85	A5.00 \$B4BB	U5 DC PCB	960-5015-01

NASCAR® (Notes 7, 8)					
Sound	(512K)	965-0429-86	2.00 \$32B3	U7	960-7001-02
Game ROM	(1M)	965-0430-86	A4.50 \$39FF	U210	960-5009-00
Voice 1	(8M)	965-0431-86	2.00 \$CFFB	U17	960-5016-00
Voice 2	(8M)	965-0432-86	2.00 \$22C0	U21	960-5016-00
Voice 3	(8M)	965-0433-86	2.00 \$5FC8	U36	960-5016-00
Voice 4	(8M)	965-0434-86	2.00 \$2902	U37	960-5016-00
Display	(4M)	965-0435-86	A4.00 \$92BD	U5 DC PCB	960-5015-01

Grand Prix (Notes 7, 8)					
Sound	(512K)	965-0429-91	V1.00 \$6F89	U7	960-7001-02
Game ROM	(1M)	965-0430-91	A4.50 \$5EFF	U210	960-5009-00
Voice 1	(8M)	965-0431-91	1.00 \$C0E5	U17	960-5016-00
Voice 2	(8M)	965-0432-91	1.00 \$F40E	U21	960-5016-00
Voice 3	(8M)	965-0433-91	1.00 \$057D	U36	960-5016-00
Voice 4	(8M)	965-0434-91	1.00 \$2646	U37	960-5016-00
Display	(4M)	965-0435-91	A4.00 \$DA8E	U5 DC PCB	960-5015-01

[NDSE] (Notes 7, 8) <i>Call for more info if code update required.</i>					
Sound	(512K)	965-0436-97		U7	960-7001-02
Game ROM	(1M)	965-0437-97		U210	960-5009-00
Voice 1	(8M)	965-0438-97		U17	960-5016-00
Voice 2	(8M)	965-0439-97		U21	960-5016-00
Voice 3	(8M)	965-0440-97		U36	960-5016-00
Voice 4	(8M)	965-0441-97		U37	960-5016-00
Display	(4M)	965-0442-97		U5 DC PCB	960-5015-01

**** GAMES BELOW THIS LINE / NEXT COLUMN ARE S.A.M. SYSTEM GAMES**

TO ORDER MEMORY STICK WITH GAME FILES FROM YOUR DISTRIBUTOR, USE SPI PART NUMBER 970-0128-00 & INCLUDE THE GAME NAME / LANGUAGE FILE(S) DESIRED.

World Poker Tour™ Pinball (WPT) (Notes 7, 9)					
Boot B-02	(8M)	965-BOOT-SAM	1.04 \$7E62	U9	960-5016-00 unprogrammed
Memory Stick 128MB (970-0128-00)		Version		System	Bin Files:
English + Spanish		1.12AL		1.17+	WPT0112AL.bin
English Only		1.12A		1.17+	WPT0112A.bin
English + French		1.12AF		1.17+	WPT0112AF.bin
French Only		1.12F		1.17+	WPT0112F.bin
German + French		1.12GF		1.17+	WPT0112GF.bin
German Only		1.12G		1.17+	WPT0112G.bin
English + Italian		1.12AI		1.17+	WPT0112AI.bin
Italian Only		1.12I		1.17+	WPT0112I.bin

NOTE: THE TYPICAL SIZE PER UNZIPPED BIN FILE IS 25MB – 30MB+/-

The Simpsons™ Kooky Carnival Redemption (Note 9)					
Boot B-02	(8M)	965-BOOT-SAM	1.04 \$7E62	U9	960-5016-00 unprogrammed
Memory Stick 128MB (970-0128-00)		Version		Bin Files:	
English Only		1.05		SKC0105.bin	
English New Jersey Only		0.09NJ		SKC0090NJ.bin	

NOTE: THE TYPICAL SIZE PER UNZIPPED BIN FILE IS 5.5MB +/-

©Disney's Pirates of the Caribbean Pinball (POTC) (Notes 7, 9)					
Boot B-02	(8M)	965-BOOT-SAM	1.06 \$2014	U9	960-5016-00 unprogrammed
Memory Stick 128MB (970-0128-00)		Version		System	Bin Files:
English + Spanish		1.15AS		1.17+	POTC115AS.bin
English + French		1.15AF		1.17+	POTC115AF.bin
German + French		1.15GF		1.17+	POTC115GF.bin
English + Italian		1.15AI		1.17+	POTC115AI.bin

NOTE: THE TYPICAL SIZE PER UNZIPPED BIN FILE IS 25MB – 30MB+/-

Family Guy™ Pinball (FG) (Notes 7, 9)					
Boot B-02	(8M)	965-BOOT-SAM	2.09 \$10A3	U9	960-5016-00 unprogrammed
Memory Stick 128MB (970-0128-00)		Version		System	Bin Files:
English + Spanish		10.00AL		1.23+	FG1000AL.bin
English + French		10.00AF		1.23+	FG1000AF.bin
English + German		10.00AG		1.23+	FG1000GF.bin
English + Italian		10.00AI		1.23+	FG1000AI.bin

NOTE: THE TYPICAL SIZE PER UNZIPPED BIN FILE IS 25MB – 30MB+/-

Spider-Man™ Pinball (S-M) (Notes 7, 9)					
Boot B-02	(8M)	965-BOOT-SAM	2.10 \$F625	U9	960-5016-00 unprogrammed
Memory Stick 128MB (970-0128-00)		Version		System	Bin Files:
English + Spanish		1.3ES		1.27+	spd_1_30_es.bin
English + French		1.3EF		1.27+	spd_1_30_ef.bin
German + French		1.3GF		1.27+	spd_1_30_gf.bin
English + Italian		1.3EI		1.27+	spd_1_30_ei.bin

NOTE: THE TYPICAL SIZE PER UNZIPPED BIN FILE IS 25MB – 30MB+/-

footnotes:

- 1 ROMs on CPU/Sound Bd.: 520-5136-00 (Stereo) & Display Cont. Bd.: 520-5055-01
- 2 ROMs on CPU/Sound Bd.: 520-5136-10 (Mono) & Display Cont. Bd.: 520-5055-01
- 3 ROMs on CPU/Sound Board: 520-5136-15* (Mono) (*FCC 11-97) & Display Controller Board: 520-5055-02* (*FCC 11-97)



APPENDIX A

Pinball Game Firmware Table

EPROM	Chip Size	Program Part N ^o	USA Ver.	Bd. Loc.	Raw Part N ^o	EPROM	Chip Size	Program Part N ^o	USA Ver.	Bd. Loc.	Raw Part N ^o
Laser War						Lethal Weapon 3					
CPU	(256K)	965-0004-00	LWAR.C5	C5	960-5007-00	CPU	(512K)	965-0082-00	A2.08	C5	960-7001-02
Sound (old)	(256K)	965-0005-00		J5	960-5007-00	Voice 1	(2M)	965-0083-00		U17	960-5010-00
Sound (old)	(256K)	965-0006-00		J6	960-5007-00	Voice 2	(2M)	965-0084-00		U21	960-5010-00
Sound (old)	(256K)	965-0007-00		J7	960-5007-00	Sound	(256K)	965-0085-00		U7	960-5007-00
			- OR -			Display	(2M)	965-0086-00	A2.06	ROM 0	960-5010-00
Sound	(256K)	965-0008-00		7F	960-5007-00	Display	(2M)	965-0087-00	A2.06	ROM 1	960-5010-00
Sound 1	(512K)	965-0009-00		6F	960-7001-02				-OR-		
Sound 2	(512K)	965-0010-00		4F	960-7001-02	Display	(4M)	965-0087-04	A2.06	ROM 0	960-5015-00
									(Used on Display PCB 520-5055-01)		
Secret Service						Star Wars					
CPU	(256K)	965-0011-00	A4-6	B5	960-5007-00	CPU	(512K)	965-0119-00	A1.03	C5	960-7001-02
CPU	(256K)	965-0012-00	A4-6	C5	960-5007-00	Voice 0	(4M)	965-0132-00		U17	960-5015-00
Voice 1	(512K)	965-0014-00		6F	960-7001-02	Voice 1	(2M)	965-0133-00		U21	960-5010-00
Voice 2	(512K)	965-0015-00		4F	960-7001-02	Sound	(256K)	965-0131-00		U7	960-5007-00
Sound	(256K)	965-0013-00		7F	960-5007-00	Display	(2M)	965-0120-00	A1.04	ROM 0	960-5010-00
						Display	(2M)	965-0121-00	A1.04	ROM 1	960-5010-00
									(Used on Display PCB 520-5055-01)		
Torpedo Alley						Rocky & Bullwinkle & Friends					
CPU	(256K)	965-0016-00	A2-1	B5	960-5007-00	CPU	(512K)	965-0138-00	A1.30	C5	960-7001-02
CPU	(256K)	965-0017-00	A2-1	C5	960-5007-00	Voice 0	(4M)	965-0139-00		U17	960-5015-00
Voice 1	(512K)	965-0018-00		6F	960-7001-02	Voice 1	(2M)	965-0140-00		U21	960-5010-00
Voice 2	(512K)	965-0019-00		4F	960-7001-02	Sound	(256K)	965-0141-00		U7	960-5007-00
Sound	(256K)	965-0018-00		7F	960-5007-00	Display	(4M)	965-0142-00	A1.30	ROM 0	960-5015-00
									-OR-		
									A1.05	ROM 0	960-5015-00
									(Used on Display PCB 520-5055-01)		
Time Machine						Jurassic Park					
CPU	(128K)	965-0021-00	A2-4	B5	960-5006-00	CPU	(512K)	965-0143-00	A5.13	C5	960-7001-02
CPU	(256K)	965-0022-00	A2-4	C5	960-5007-00	Voice 0	(4M)	965-0144-00		U17	960-5015-00
Voice 1	(512K)	965-0024-00		6F	960-7001-02	Voice 1	(2M)	965-0145-00		U21	960-5010-00
Voice 2	(512K)	965-0025-00		4F	960-7001-02	Sound	(256K)	965-0146-00		U7	960-5007-00
Sound	(256K)	965-0023-00		7F	960-5007-00	Display	(4M)	965-0147-00	A5.10	ROM 0	960-5015-00
Playboy 35th Anniversary						Last Action Hero					
CPU	(256K)	965-0046-00	A2-4	B5	960-5007-00	CPU	(512K)	965-0148-00	A1.12	C5	960-7001-02
CPU	(256K)	965-0047-00	A2-4	C5	960-5007-00	Voice 0	(4M)	965-0149-00		U17	960-5015-00
Voice 1	(512K)	965-0049-00		6F	960-7001-02	Voice 1	(2M)	965-0150-00		U21	960-5010-00
Voice 2	(512K)	965-0050-00		4F	960-7001-02	Sound	(256K)	965-0151-00		U7	960-5007-00
Sound	(256K)	965-0048-00		7F	960-5007-00	Display	(4M)	965-0152-00	A1.06	ROM 0	960-5015-00
ABC Monday Night Football						Tales from the Crypt					
CPU	(128K)	965-0031-00	A2-7	B5	960-5006-00	CPU	(512K)	965-0157-00	A3.03	C5	960-7001-02
CPU	(256K)	965-0032-00	A2-7	C5	960-5007-00	Voice 0	(4M)	965-0158-00		U17	960-5015-00
Voice 1	(512K)	965-0034-00		6F	960-7001-02	Voice 1	(2M)	965-0159-00		U21	960-5010-00
Voice 2	(512K)	965-0035-00		4F	960-7001-02	Sound	(256K)	965-0160-00		U7	960-5007-00
Sound	(256K)	965-0033-00		7F	960-5007-00	Display	(4M)	965-0161-00	A3.01	ROM 0	960-5015-00
Robocop						The Who's Tommy					
CPU	(256K)	965-0036-00	A3-4	B5	960-5007-00	CPU	(512K)	965-0162-00	A4.00	C5	960-7001-02
CPU	(256K)	965-0037-00	A3-4	C5	960-5007-00	Voice 1	(4M)	965-0163-00		U17	960-5015-00
Voice 1	(512K)	965-0039-00		6F	960-7001-02	Voice 2	(4M)	965-0166-00		U21	960-5010-00
Voice 2	(512K)	965-0040-00		4F	960-7001-02	Voice 3	(4M)	965-0167-00		U36	960-5015-00
Sound	(256K)	965-0038-00		7F	960-5007-00	Voice 4	(4M)	965-0168-00		U37	960-5015-00
						Sound	(512K)	965-0164-00		U7	960-7001-02
						Display	(4M)	965-0163-00	A4.00	ROM 0	960-5015-00
Phantom of the Opera						WWF Royal Rumble					
CPU	(128K)	965-0026-00	A3-2	B5	960-5006-00	CPU	(512K)	965-0169-00	A1.06	C5	960-7001-02
CPU	(256K)	965-0027-00	A3-2	C5	960-5007-00	Voice 1	(4M)	965-0172-00		U17	960-5015-00
Voice 1	(512K)	965-0029-00		6F	960-7001-02	Voice 2	(4M)	965-0173-00		U21	960-5010-00
Voice 2	(512K)	965-0030-00		4F	960-7001-02	Voice 3	(4M)	965-0174-00		U36	960-5015-00
Sound	(256K)	965-0028-00		7F	960-5007-00	Sound	(512K)	965-0171-00		U7	960-7001-02
						Display	(4M)	965-0170-00	A1.02	ROM 0	960-5015-00
Back to the Future						Guns N' Roses					
CPU	(256K)	965-0041-00	A2-0	B5	960-5007-00	CPU	(512K)	965-0175-00	A3.00	C5	960-7001-02
CPU	(256K)	965-0042-00	A2-0	C5	960-5007-00	Voice 1	(4M)	965-0178-00		U17	960-5015-00
Voice 1	(512K)	965-0044-00		6F	960-7001-02	Voice 2	(4M)	965-0179-00		U21	960-5010-00
Voice 2	(512K)	965-0045-00		4F	960-7001-02	Voice 3	(4M)	965-0180-00		U36	960-5015-00
Sound	(256K)	965-0043-00		7F	960-5007-00	Voice 4	(4M)	965-0181-00		U37	960-5015-00
						Sound	(512K)	965-0177-00		U7	960-7001-02
						Display	(4M)	965-0176-00	A3.00	ROM 0	960-5015-00
The Simpsons						Maverick *					
CPU	(128K)	965-0051-00	A2-7	B5	960-5006-00	CPU	(512K)	965-0182-00	A4.04	C5	960-7001-02
CPU	(256K)	965-0052-00	A2-7	C5	960-5007-00	Voice 1	(4M)	965-0186-00		U17	960-5015-00
Voice 1	(512K)	965-0054-00		6F	960-7001-02	Voice 2	(4M)	965-0187-00		U21	960-5010-00
Voice 2	(512K)	965-0055-00		4F	960-7001-02	Voice 3	(4M)	965-0187-01		U36	960-5015-00
Sound	(256K)	965-0053-00		7F	960-5007-00	Sound	(512K)	965-0185-00		U7	960-7001-02
						Display*	(4M)	965-0183-00	A4.01	ROM 0	960-5015-00
						Display*	(4M)	965-0184-00	A4.01	ROM 3	960-5015-00
Checkpoint						Mary Shelley's Frankenstein *					
CPU	(128K)	965-0056-00	A1-7	B5	960-5006-00	CPU	(512K)	965-0188-00	A1.03	C5	960-7001-02
CPU	(256K)	965-0134-00	A1-7	C5	960-5007-00	Voice 1	(4M)	965-0192-00		U17	960-5015-00
Voice 1	(1M)	965-0057-00		F7	960-5009-00	Voice 2	(4M)	965-0193-00		U21	960-5010-00
Voice 2	(1M)	965-0058-00		F5	960-5009-00	Voice 3	(4M)	965-0194-00		U36	960-5015-00
Sound	(256K)	965-0059-00		F4	960-5007-00	Sound	(512K)	965-0191-00		U7	960-7001-02
Display	(512K)	965-0060-00	CP80	U8	960-7001-02	Display*	(4M)	965-0189-00	A1.03	ROM 0	960-5015-00
						Display*	(4M)	965-0190-00	A1.03	ROM 3	960-5015-00
Teenage Mutant Ninja Turtles						Baywatch *					
CPU	(128K)	965-0061-00	A1.04	B5	960-5006-00	CPU	(512K)	965-0195-00	A4.00	C5	960-7001-02
CPU	(256K)	965-0062-00	A1.04	C5	960-5007-00	Voice 1	(4M)	965-0196-00		U17	960-5015-00
Voice 1	(1M)	965-0063-00		F5/6	960-5009-00	Voice 2	(4M)	965-0197-00		U21	960-5010-00
Voice 2	(1M)	965-0064-00		F4/5	960-5009-00	Sound	(512K)	965-0199-00		U7	960-7001-02
Sound	(256K)	965-0065-00		F7	960-5007-00	Display*	(4M)	965-0200-00	A4.00	ROM 0	960-5015-00
Display	(512K)	965-0066-00	A1.04	U8	960-7001-02	Display*	(4M)	965-0201-00	A4.00	ROM 3	960-5015-00
Batman						Batman Forever *					
CPU	(128K)	965-0067-00	A1.06	B5	960-5006-00	CPU	(512K)	965-0202-00	A3.02	C5	960-7001-02
CPU	(256K)	965-0135-00	A1.06	C5	960-5007-00	Voice 1	(4M)	965-0203-00		U17	960-5015-00
Voice 1	(2M)	965-0068-00		U17	960-5010-00	Voice 2	(4M)	965-0204-00		U21	960-5010-00
Voice 2	(1M)	965-0069-00		U21	960-5010-00	Sound	(512K)	965-0205-00		U7	960-7001-02
Sound	(256K)	965-0070-00		U7	960-5007-00	Display*	(4M)	965-0206-00	A3.00	ROM 0	960-5015-00

APPENDIX B

Semi-Conductors / Integrated Circuits (I.C.) / Relays Cross-Reference Table

Table No	Type	Source Number	STERN® PINBALL	N T E®	E C G®	Radio Shack®	R C A®
RECTIFICATION, BLOCKING, DAMPENING DIODES AND/OR LIGHT EMITTING DIODES (LEDs)							
1	Diode	1N4001	112-5001-00	NTE552	ECG552	- - - - -	SK9000
	Diode	1N4004	112-5003-00	NTE116	ECG116	276-1103	SK3312
	Diode	1N5401	112-0056-00	NTE5801	ECG5801	276-1143	SK9004
	Diode	1N5404	112-5004-00	NTE5804	ECG5804	276-1144	SK9007
	Diode	T6A10L	112-5006-01	NTE5812	ECG5812	- - - - -	- - - - -
	Diode	FR302	112-5009-00	NTE588	ECG588	- - - - -	SK5014
	Diode, Signal	1N914	112-5014-00	- - - - -	- - - - -	- - - - -	- - - - -
LED	MT5000UR or TLRH180P (T1-3/4 GaAlAs)	165-5052-00 <i>(old SPI Part No: 165-5100-00)</i>	- - - - -	- - - - -	276-066B	- - - - -	
ZENER DIODES							
2	Diode	1N4742A 12v	112-0061-00	NTE142A	ECG142A	276-563	SK12V
	Diode	1N4760B 68v	112-0062-00B	NTE5092A	ECG5092A	- - - - -	SK68V
	Diode	1N4764A 100v	112-0049-00A	NTE5096A	ECG5096A	- - - - -	SK100V
	Diode	1N5228 3.9v	112-0053-00	NTE5007A	ECG5007A	- - - - -	SK3A9
	Diode	1N5234B 6.2v	112-0047-00B	NTE5013A	ECG5013A	276-561	SK6A2
	Diode	1N5379 110v	112-0072-00	NTE5157	ECG5157	- - - - -	SK110X
	Diode	1N6267A 6.8v	112-5011-00	NTE4902	ECG4902	- - - - -	- - - - -
	Diode	1N4752A 33v	112-5010-00A	NTE147A	ECG147A	- - - - -	SK33V
Diode	1N4736 6.8v 1w	112-5007-00	NTE5071A	ECG5071A	- - - - -	- - - - -	
TRANSISTORS - TYPE FET, NPN, PNP AND/OR SCR							
3	FET Trans.	STP20N10L	110-0106-00	NTE2987	ECG2987	- - - - -	- - - - -
	FET Trans.	STP19N06L	110-0088-00	NTE2985	ECG2985	- - - - -	- - - - -
	FET Trans.	VN02N	110-0089-00	- - - - -	- - - - -	- - - - -	- - - - -
	NPN Trans.	2N4401	110-0073-00	NTE85	ECG85	276-2009	SK3124A
	NPN Trans.	2N6427	110-0070-00	NTE48	ECG48	- - - - -	SK4906
	NPN Trans.	MJE340	110-0071-00	NTE157	ECG157	- - - - -	SK3747
	NPN Trans.	MPSA42	110-0082-00	NTE287	ECG287	- - - - -	SK3232
	NPN Trans.	2N3904	110-0069-00	NTE123AP	ECG123AP	276-2009	- - - - -
	NPN Trans.	TIP122	110-0067-00	NTE261	ECG261	276-2068	SK3896
	NPN Trans.	MJE15030	110-0101-00	NTE375	ECG375	- - - - -	SK9118
	PNP Trans.	2N5401	110-0078-00	NTE288	ECG288	- - - - -	SK3434
	PNP Trans.	MJE15031	110-0103-00	NTE292	ECG292	- - - - -	SK3441
	PNP Trans.	MJE350	110-0072-00	NTE374	ECG374	- - - - -	SK9042
	PNP Trans.	MPSA92	110-0100-00	NTE288	ECG278	- - - - -	SK3434
	PNP Trans.	TIP42	110-0068-00	NTE332	ECG332	- - - - -	SK9236
	PNP Trans.	TIP32C	110-0081-00	NTE292	ECG292	- - - - -	SK3441
	PNP Trans.	TIP36C	110-0077-00	NTE393	ECG393	- - - - -	SK3961
	SCR Trans.	2N5060	110-0074-00	NTE5400	ECG5400	276-1067	SK3950
SCR Trans.	SCR2800B	110-0083-00	NTE5461-8	ECG5461-8	- - - - -	- - - - -	
BRIDGE RECTIFIERS (BR)				Comments:			
4	BR (Present)	DB3501 or CM3501	112-5000-00	For White Star I/O Bds., BR = 35 Amp @ 100v P.I.V.			
	RELAYS				Comments:		
5	Relay	FRL-264 D024/02CK	190-5002-00	For PPB, Power Supply, & White Star I/O Boards, Relay = 24v DC 10 Amp DPDT			
	Relay	FRL-264 D006/04CV	190-5001-00	For CPU Boards, Relay = 6v DC 5 Amp 4 Pole DT			





APPENDIX C

Production Start Date, Manual Part No., ROM Size & Positions and Jumper W6 Installed Note‡ (White Star Board System & S.A.M. System Only*)



Game Name White Star Bd. System™	Production Start Date and Manual Part Nr.	CPU/Sound Board Sound U7 512K CPU/Sound Board Game U210 1MB CPU/Sound Board Voice ROMS:				Jumper Installed (‡ see Note)	
		U17	U21	U36	U37		
<p>* Note: For complete Appendix Information for Games <i>Laser War</i> through <i>Batman Forever</i>, see any Service Game Manual between <i>Apollo 13</i> through <i>Ripley's Believe It or Not!</i> or on-line at our website www.sternpinball.com/parts.htm; also available on CD-R, 970-2003-00 (<i>The Simpsons™ Pinball Party</i>, <i>T3®</i> and <i>The Lord of the Rings™</i>).</p>							
29	Apollo 13 (A13)	NOV 95 780-5044-00	4MB	4MB	4MB	Not Used	n / a
30	Golden Eye	FEB 96 780-5042-00	4MB	4MB	Not Used	Not Used	n / a
31	Twister	APR 96 780-5041-00	4MB	4MB	Not Used	Not Used	n / a
32	ID4: Independence Day	JUL 96 780-5045-00	4MB	4MB	Not Used	Not Used	n / a
33	Space Jam	OCT 96 780-5043-00	4MB	4MB	4MB	Not Used	n / a
34	The Star Wars Trilogy - Sp. Ed.	FEB 97 780-5056-00	4MB	4MB	Not Used	Not Used	n / a
35	The Lost World: Jurassic Park	JUN 97 780-5053-00	4MB	4MB	Not Used	Not Used	n / a
36	The X-Files	AUG 97 780-5046-00	4MB	4MB	Not Used	Not Used	n / a
37	Starship Troopers	NOV 97 780-5059-00	4MB	4MB	4MB	Not Used	n / a
38	Viper Night Drivin'	FEB 98 780-5035-00	4MB	4MB	4MB	4MB	n / a
39	Lost In Space	JUN 98 780-5060-00	4MB	4MB	4MB	4MB	n / a
40	Godzilla	SEP 98 780-5040-00	4MB	4MB	4MB	4MB	n / a
41	South Park	JAN 99 780-5071-00	8MB	8MB	8MB	8MB	W6
42a	Harley-Davidson®	AUG 99 780-5067-01	8MB	8MB	8MB	8MB	W6
42b	Harley-Davidson® 2nd Ed.	SEP 02 780-5067-10	8MB	8MB	8MB	8MB	W6
42c	Harley-Davidson® 3rd Ed.	OCT 04 780-5087-00	8MB	8MB	8MB	8MB	W6
43a	Striker Xtreme	MAR 00 780-5068-01	8MB	8MB	8MB	8MB	W6
43b	NFL	OCT 00 780-5073-00	8MB	8MB	8MB	8MB	W6
44	Sharkey's Shootout	JUL/OCT 00 780-5072-01	8MB	8MB	8MB	Not Used	W6
45	High Roller Casino	JAN 01 780-5065-00	8MB	8MB	8MB	8MB	W6
46	Austin Powers™	MAY 01 780-5074-00	8MB	8MB	8MB	8MB	W6
47	MONOPOLY®	SEP 01 780-5075-00	8MB	8MB	8MB	Not Used	W6
48	Playboy	FEB 02 780-5076-00	8MB	8MB	8MB	8MB	W6
49	RollerCoaster Tycoon™	AUG 02 780-5078-00	8MB	8MB	8MB	Not Used	W6
50	The Simpsons™ Pinball Party	JAN 03 780-5077-00	8MB	8MB	8MB	8MB	W6
51	T3®: Rise of the Machines™	MAY 03 780-5079-00	8MB	8MB	8MB	8MB	W6
52	The Lord of the Rings™	NOV 03 780-5080-00	8MB	8MB	8MB	8MB	
53	Ripley's Believe It or Not!®	APR 04 780-5081-00	8MB	8MB	8MB	8MB	

‡ Additional Information for Installed Jumper (above games 41-51):

• Installed **W6** so 8MB ROMS can be utilized. See the **CPU/Sound Board Schematic** (Sheet 2 of 3, Address Location 3E) in the games' Service Game Manual. Games 52 - 57 CPU/Sound Board differ than <51 (See Appendix D).

See **Apdx. A** for more detailed information on **Pinball Game Firmware** (ROM Name, Size, Part Numbers, USA Version & Checksum and Board Locations).

Game Name White Star Board System™	Production Start Date and Manual Part Nr.	CPU/Sound Board Sound U7 512K CPU/Sound Board Game U210 1MB CPU/Sound Board Voice ROMS:				
		U17	U21	U36	U37	
54	Elvis®	AUG 04 780-5084-00	8MB	8MB	8MB	8MB
55	The Sopranos™	FEB 05 780-5085-00	8MB	8MB	8MB	8MB
56	NASCAR®	JUL 05 780-5086-00	8MB	8MB	8MB	8MB
57	Grand Prix	SEP 05 780-5091-00	8MB	8MB	8MB	8MB

See **Apdx. A** for more detailed information on **Pinball Game Firmware** (ROM Name, Size, Part Numbers, USA Version & Checksum and Board Locations).

Game Name S.A.M. System	Production Start Date and Manual Part Nr.	S.A.M. System CPU/Sound Board Boot EPROM U9			
		965-BOOT-SAM (Programmed)			
58	World Poker Tour™ (WPT)	JUN 06 780-5088-00	8MB	B-02 V2.1+ chksum \$F625	LOC: U9
59	The Simpsons™ Kooky Carnival	APR 06 780-5090-00	8MB	B-02 V2.1+ chksum \$F625	LOC: U9
60	©Disney's Pirates of the Caribbean	AUG 06 780-5092-00	8MB	B-02 V2.1+ chksum \$F625	LOC: U9
61	Famil Guy™	DEC 06 780-5093-00	8MB	B-02 V2.1+ chksum \$F625	LOC: U9
62	Spider-Man™	MAY 07 780-5094-00	8MB	B-02 V2.1+ chksum \$F625	LOC: U9

Games 58 – current, S.A.M. System : CPU/Sound & I/O Power Driver PCBs differ than White Star (previous Games 29 – 57); Disp. Controller Not Required.





APPENDIX D

Board Type (White Star Board System* Only) Table



Game Name	Flipper	I/O Power Driver	CPU/Sound Stereo	Disp. Power Supply	Dot Matrix Display	Display Controller	OPTO Transmitter	OPTO Receiver	OPTO Application
Apollo 13	520-5080-00 2-Flipper	520-5137-00	520-5136-00	520-5138-00	520-5052-00 128 X 32 Dots	520-5055-01	520-5124-00 Single OPTO	520-5125-00 Single OPTO	5-Ball Trough over Up-Kicker
	Miscellaneous PC Boards:	Light Boards 520-5130-01, -04 & -05 Magnet Interface, 7-Segment Display & Light Bd. 520-5130-06 Magnet Driver Board 520-5130-02 Switch Membrane Board 520-5130-03				Relay Board 520-5010-00			
Golden Eye	520-5080-00 2-Flipper	520-5137-00	520-5136-00	520-5138-00	520-5052-00 128 X 32 Dots	520-5055-01	520-5124-00 Single OPTO	520-5125-00 Single OPTO	5-Ball Trough over Up-Kicker
	Miscellaneous PC Boards:	Light Boards 520-5128-05 through -08		Mag. Processor X2 Driver Bd. 520-5143-00	Relay Board 520-5010-00				
GAMES HEREON NO LONGER REQUIRE THE FLIPPER BOARD WITH THE WHITE STAR BOARD SYSTEM™									
Game Name	I/O Power Driver	CPU/Sound Mono	Disp. Power Supply	Dot Matrix Display	Display Controller	OPTO Transmitter	OPTO Receiver	OPTO Application	Misc OPTO & App.
Twister	520-5137-01	520-5136-10	520-5138-00	520-5052-00 128 X 32 Dots	520-5055-01	520-5124-00 Single OPTO	520-5125-00 Single OPTO	5-Ball Trough over Up-Kicker	
	Miscellaneous PC Boards:	Light Boards 520-5145-01 through -07		Mag. Drv. Bd. 520-5143-00	Relay Board 520-5010-00				
Independence Day (ID4)	520-5137-01	520-5136-10	520-5138-00	520-5052-00 128 X 32 Dots	520-5055-01	520-5124-00 Single OPTO	520-5125-00 Single OPTO	4-Ball Trough over Up-Kicker	
	Miscellaneous PC Boards:	Light Boards 520-5149-01 through -10		Servo Mtr. Bd. 520-5152-00		520-5082-00 Long Hop OPTO	520-5083-00 Long Hop OPTO	Alien Head Enter	
Space Jam	520-5137-01	520-5136-10	520-5138-00	520-5052-00 128 X 32 Dots	520-5055-01	520-5124-00 Single OPTO	520-5125-00 Single OPTO	5-Ball Trough over Up-Kicker	
	Miscellaneous PC Boards:	2X 7-Segment Display Board 520-5153-00							
The Star Wars Trilogy - Special Ed.	520-5137-01	520-5136-10	520-5138-00	520-5052-00 128 X 32 Dots	520-5055-01	520-5124-00 Single OPTO	520-5125-00 Single OPTO	4-Ball Trough over Up-Kicker	
	Miscellaneous PC Boards:	Relay Board 520-5010-00							
The Lost World: J.P.	520-5137-01	520-5136-10	520-5138-00	520-5052-00 128 X 32 Dots	520-5055-01	520-5124-00 Single OPTO	520-5125-00 Single OPTO	4-Ball Trough over Up-Kicker	520-5162-00 2-Pos. Motor Sensor on Snagger Motor
	Miscellaneous PC Boards:	DC Relay Bd. 520-5066-00	Shaker Mtr. Bd. 520-5065-00						
The X-Files	520-5137-01	520-5136-10	520-5138-00	520-5052-00 128 X 32 Dots	520-5055-01	520-5124-00 Single OPTO	520-5125-00 Single OPTO	4-Ball Trough over Up-Kicker	520-5155-00 3-Pos. Motor Sensor on File Cab. Motor
	Miscellaneous PC Boards:					520-5082-00 Long Hop OPTO	520-5083-00 Long Hop OPTO	File Cabinet Enter	
Starship Troopers	520-5137-01	520-5136-15	520-5138-00	520-5052-00 128 X 32 Dots	520-5055-02	520-5124-00 Single OPTO	520-5125-00 Single OPTO	4-Ball Trough over Up-Kicker	
	Miscellaneous PC Boards:	4X 7-Segment Display Board 520-5166-00				520-5082-00 Long Hop OPTO	520-5083-01 Long Hop OPTO	L/R Orbit Lane Enter	
Viper Night Drivin'	520-5137-01	520-5136-16	520-5138-00	520-5052-00 128 X 32 Dots	520-5055-03	520-5124-00 Single OPTO	520-5125-00 Single OPTO	4-Ball Trough over Up-Kicker	
	Miscellaneous PC Boards:	Relay Board 520-5010-00				520-5082-00 Long Hop OPTO	520-5083-01 Long Hop OPTO	Jump Ramp	
Lost In Space	520-5137-01	520-5136-16	520-5138-00	520-5052-00 128 X 32 Dots	520-5055-03	515-0173-00 Dual OPTO	515-0174-00 Dual OPTO	4-Ball Trough over Up-Kicker	
	Miscellaneous PC Boards:	Relay Board 520-5010-00							
Godzilla	520-5137-01	520-5136-16	520-5138-00	520-5052-00 128 X 32 Dots	520-5055-03	515-0173-00 Dual OPTO	515-0174-00 Dual OPTO	4-Ball Trough over Up-Kicker	
	Miscellaneous PC Boards:	Shaker Mtr. Bd. 520-5065-00							
South Park	520-5137-01	520-5136-16	520-5138-00	520-5052-00 128 X 32 Dots	520-5055-03	515-0173-00 Dual OPTO	515-0174-00 Dual OPTO	5-Ball Trough over Up-Kicker	
	Miscellaneous PC Boards:					520-5082-00 Long Hop OPTO	520-5083-01 Long Hop OPTO	Kenny Under Trough Enter	
Harley-Davidson® 1st-3rd* Editions	520-5137-01	520-5136-16 *520-5300-00*	520-5138-00	520-5052-00 128 X 32 Dots	520-5055-03	515-0173-00 Dual OPTO	515-0174-00 Dual OPTO	4-Ball Trough over Up-Kicker	
	Miscellaneous PC Boards:	Relay Board 520-5010-00		Shaker Mtr. Bd. 520-5065-00	Diode Board 520-5146-00	520-5082-00 Long Hop OPTO	520-5083-01 Long Hop OPTO	Motorcycle Enter	
Striker Xtreme (NFL)	520-5137-01	520-5136-16	520-5138-00	520-5052-00 128 X 32 Dots	520-5055-03	515-0173-00 Dual OPTO	515-0174-00 Dual OPTO	4-Ball Trough over Up-Kicker	520-5155-00 3-Pos. Motor Sensor on Goalie Motor
	Miscellaneous PC Boards:	DC Relay Bd. 520-5066-00	Relay Board 520-5010-00	Diode Board 520-5146-00	for UK ONLY- Solenoid Expander Bd. 520-5192-00	520-5082-00 Long Hop OPTO	520-5083-01 Long Hop OPTO	Goalie Under- Trough Enter	
Sharkey's Shootout	520-5137-64	520-5136-64	520-5138-00	520-5052-00 128 X 32 Dots	520-5055-03	515-0173-00 Dual OPTO	515-0174-00 Dual OPTO	4-Ball Trough over Up-Kicker	520-5194-00 4-Pos. Motor Sensor on ? -Ball Motor
	Miscellaneous PC Boards:	Relay Board 520-5010-00		Sol. Exp. Bd. 520-5192-00					
High Roller Casino	520-5137-01	520-5136-16	520-5138-00	520-5052-00 128 X 32 Dots	520-5055-03	515-0173-00 Dual OPTO	515-0174-00 Dual OPTO	4-Ball Trough over Up-Kicker	520-5194-00 4-Pos. Motor Sensor on Roulette Wheel Motor
	Miscellaneous PC Boards:	Dot Display (5X7) in Slot Mach. 520-5197-00			for UK ONLY- Solenoid Expander Bd. 520-5192-00	520-5196-00 3-Pos. OPTO	520-5195-00 3-Pos. OPTO	Ball Lock under Roulette	Up/Dn Ramp in Slot Mach.
Austin Powers™	520-5137-01	520-5136-16	520-5138-00	520-5052-00 128 X 32 Dots	520-5055-03	515-0173-00 Dual OPTO	515-0174-00 Dual OPTO	4-Ball Trough over Up-Kicker	520-5212-00 Pulse-Stretcher OPTO on Spini-Me
	Miscellaneous PC Boards:	Relay Bd. (X3) 520-5010-00			for UK ONLY- Solenoid Expander Bd. 520-5192-00	520-5082-00 Long Hop OPTO	520-5083-01 Long Hop OPTO	Time Machine Ramp	
MONOPOLY®	520-5137-01	520-5136-16	520-5138-00	520-5052-00 128 X 32 Dots	520-5055-03	515-0173-00 Dual OPTO	515-0174-00 Dual OPTO	4-Ball Trough over Up-Kicker	
	Miscellaneous PC Boards:	DC Relay Bd. 520-5066-00	Mini-Dot Display (3 by 5X7) 520-5197-00 (Electric C- Sign)		for UK ONLY- Solenoid Expander Bd. 520-5192-00	520-5218-00 4-Pos. OPTO	520-5210-00 4-Pos. OPTO	Bank Door	

Table continued on the next page.





APPENDIX D

Board Type (White Star Board System* & S.A.M. System** Only) Table



Game Name	I/O Power Driver	CPU/Sound (old & new)	Disp. Power Supply	Dot Matrix Display	Display Controller	OPTO Transmitter	OPTO Receiver	OPTO Application	Misc OPTO & App.
Playboy	520-5137-01	520-5136-16	520-5138-00	520-5052-00 128 X 32 Dots	520-5055-03	515-0173-00 Dual OPTO	515-0174-00 Dual OPTO	4-Ball Trough over Up-Kicker	
	Miscellaneous PC Boards:	DC Relay Bd. 520-5066-00	Relay Bd. 520-5010-00		for UK ONLY- Solenoid Expander Bd. 520-5192-00				
RollerCoaster Tycoon™	520-5137-01	520-5136-16	520-5138-00	520-5052-00 128 X 32 Dots	520-5055-03	515-0173-00 Dual OPTO	515-0174-00 Dual OPTO	4-Ball Trough over Up-Kicker	520-5222-00 1-Position Switch Detect on Wheel Spin
	Miscellaneous PC Boards:	DC Relay Bd. 520-5066-00	Mini-Dot Display (3 by 5X7) 520-5221-00 (Ramp Enter Sign)		for UK ONLY- Solenoid Expander Bd. 520-5192-00	520-5082-00 Long Hop OPTO	520-5083-01 Long Hop OPTO	Behind 1-Bank Drop Target	
The Simpsons™ Pinball Party	520-5137-01	520-5136-16	520-5138-00	520-5052-00 128 X 32 Dots	520-5055-03	515-0173-00 Dual OPTO	515-0174-00 Dual OPTO	4-Ball Trough over Up-Kicker	
	Miscellaneous PC Boards:	LED Bd. 520-5219-00	Color Dot Display (4 by 5X7) 520-5225-00 (TV Set)		for UK ONLY ◀◀◀ Aux. Driver Bd. 520-5068-01				
Terminator® 3: Rise of the Machines™	520-5137-01	520-5136-16	520-5138-00	520-5052-00 128 X 32 Dots	520-5055-03	515-0173-00 Dual OPTO	515-0174-00 Dual OPTO	4-Ball Trough over Up-Kicker	
	Miscellaneous PC Boards:				for UK ONLY ◀◀◀ Aux. Driver Bd. 520-5068-01	515-7307-00 Single OPTO	515-7308-00 Single OPTO	TXCannon Trough	
The Lord of the Rings™	520-5137-01	New 520-5300-00	520-5138-00	520-5052-00 128 X 32 Dots	520-5055-03	515-0173-00 Dual OPTO	515-0174-00 Dual OPTO	4-Ball Trough over Up-Kicker	500-6746-00 (White Trans.) 500-6747-00 (Black Rec.)
	Miscellaneous PC Boards:	19-LED PCB 520-5242-00	OPTO Transmitter / Receiver Amplifier PCB 520-5239-00		for UK ONLY ◀◀◀ Aux. Driver Bd. 520-5068-01	515-7307-00 Single OPTO	515-7308-00 Single OPTO	Orthanc Tower Trough	
Ripley's Believe It or Not!®	520-5137-01	520-5300-00	520-5138-00	520-5052-00 128 X 32 Dots	520-5055-03	515-0173-00 Dual OPTO	515-0174-00 Dual OPTO	4-Ball Trough over Up-Kicker	500-6775-00 OPTO Trnscvr
	Miscellaneous PC Boards:	520-5236-00 X3 Dot Display	OPTO Transmitter / Receiver Amplifier PCB 520-5239-01		for UK ONLY ◀◀◀ Aux. Driver Bd. 520-5068-01	520-5234-00 3-Pos. OPTO	520-5234-00 3-Pos. OPTO	Vari-Target	520-5235-03 X3 Aux. Drvr
Elvis®	520-5137-01	520-5300-00	520-5138-00	520-5052-00 128 X 32 Dots	520-5055-03	515-0173-00 Dual OPTO	515-0174-00 Dual OPTO	4-Ball Trough over Up-Kicker	
	Miscellaneous PC Boards:				for UK ONLY ◀◀◀ Aux. Driver Bd. 520-5068-01				
The Sopranos™	520-5137-01	520-5300-00	520-5138-00	520-5052-00 128 X 32 Dots	520-5055-03	515-0173-00 Dual OPTO	515-0174-00 Dual OPTO	4-Ball Trough over Up-Kicker	
	Miscellaneous PC Boards:				for UK ONLY ◀◀◀ Aux. Driver Bd. 520-5068-01				
NASCAR® and [NDSE]	520-5137-01	520-5300-00	520-5138-00	520-5052-00 128 X 32 Dots	520-5055-03	515-0173-00 Dual OPTO	515-0174-00 Dual OPTO	4-Ball Trough over Up-Kicker	500-6775-00 OPTO Trans. (Qty. 16) Switch Detect.
	Miscellaneous PC Boards:	520-5235-03 X3 Aux. Drvr	OPTO Transmitter / Receiver Amplifier PCB 520-5239-01		for UK ONLY ◀◀◀ Aux. Driver Bd. 520-5068-01				
Grand Prix	520-5137-01	520-5300-00	520-5138-00	520-5052-00 128 X 32 Dots	520-5055-03	515-0173-00 Dual OPTO	515-0174-00 Dual OPTO	4-Ball Trough over Up-Kicker	500-6775-00 OPTO Trans. (Qty. 16) Switch Detect.
	Miscellaneous PC Boards:	520-5235-03 X3 Aux. Drvr	OPTO Transmitter / Receiver Amplifier PCB 520-5239-01		for UK ONLY ◀◀◀ Aux. Driver Bd. 520-5068-01				

Game Name	I/O Power Driver**	CPU / Sound**	Disp. Power Supply	Dot Matrix Display	Dual OPTO Transmitter	Dual OPTO Receiver	Dual OPTO Transceiver	OPTO Transceiver Miscellaneous
World Poker Tour™ (WPT)	520-5249-00 Backbox	520-5246-00 Backbox	520-5138-00 Backbox	520-5052-00 128 X 32 Dots	515-0173-00 4-Ball Trough	515-0174-00 4-Ball Trough	500-6775-00 4 Switch Pairs (Qty. 8)	520-5251-00 'U' 1/per PCB Jail Bars Up Ace/Hole Mech 520-5252-04 'U' 4/per PCB Drop Targets 4- & 8- Banks
	Miscellaneous PCBs:	520-5254-00 50V Step-Up Drv	520-5250-14 14LED 5X7 Disp.	520-5239-01 OPTO Amplifier	520-5247-00 Ace/Hole Mech	520-5248-00 Ace/Hole Mech		
The Simpsons™ Kooky Carnival	520-5249-00 Back Door	520-5246-00 Back Door	520-5138-00 Cabinet Rear	520-5052-00 128 X 32 Dots			520-5253-00-ASY Coin Drop (Qty. 11)	
	Miscellaneous PCBs:	515-5742-00 Shaker PCB	500-6700-00 Relay (incl. Wiring + Conn.)					
©Disney's Pirates of the Caribbean	520-5249-00 Backbox	520-5246-00 Backbox	520-5138-00 Backbox	520-5052-00 128 X 32 Dots	515-0173-00 4-Ball Trough	515-0174-00 4-Ball Trough	500-6775-00 5 Switch Pairs (Qty. 10)	
	Miscellaneous PCBs:	520-5239-01 OPTO Amp. (X3)	511-5024-03 Relay (incl. Wiring + Conn.)	520-5238-00 : H-E-A-R-T LED PCB				
Family Guy™	520-5249-00 Backbox	520-5246-00 Backbox	520-5138-00 Backbox	520-5052-00 128 X 32 Dots	515-0173-00 4-Ball Trough	515-0174-00 4-Ball Trough	500-6775-00 3 Switch Pairs (Qty. 6)	520-5252-01 'U' 1/per PCB Drop Target 1-Bank
	Miscellaneous PCBs:	520-5239-01 OPTO Amp. (X2)	520-5261-00 Stepper Motor	511-5042-01 Trgt. Sensor (X2)			500-6775-01 1 Switch Pair (Qty. 2)	520-5252-04 'U' 4/per PCB Drop Target 4-Bank
Spider-Man™	520-5249-00 Backbox	520-5246-00 Backbox	520-5138-00 Backbox	520-5052-00 128 X 32 Dots	515-0173-00 4-Ball Trough	515-0174-00 4-Ball Trough	500-6775-00 3 Switch Pairs (Qty. 6)	
	Miscellaneous PCBs:	520-5239-01 OPTO Amp. (X2)						



APPENDIX D

Board Type Table

Game Name	Flipper	Sound	Power Supply	Display X-Digit
• Laser War	2-Flipper Board Not Required	<i>initial:</i> 520-5002-00 <i>replaced with:</i> 520-5002-02 <i>520-5002-01 was not used.</i>	520-5000-00	Master: 520-5004-00 plus: 520-5005-00 (Qty. 2); 7 Digit Alpha/Numeric 520-5006-00 (Qty. 2); 7 Digit Numeric 520-5007-00 (Qty. 1); 4 Digit Numeric
• Secret Service • Torpedo Alley	3-Flipper Board Not Required	520-5002-02		520-5014-01 7 Digit Alpha/Numeric Combined
• Time Machine	2-Flipper Board Not Required			520-5030-00 16 Digit Alpha/Numeric Combined
• Playboy 35th Anniversary * • ABC Monday Night Football * • Robocop • Phantom of the Opera • Back to the Future • The Simpsons	520-5033-00 2-Flipper <i>(*only for 100 games of Playboy 35th Anniv. & ABC Mon. Night Football)</i>			
		520-5002-03		

Game Name	Flipper	Sound	Power Supply	Dot Matrix Display	Display Controller	OPTO Transmitter	OPTO Receiver	OPTO Application			
• Checkpoint • Teenage Mutant Ninja Turtles	520-5033-00 2-Flipper	520-5002-03	520-5047-00	520-5042-00 128 X 16	520-5055-00						
• Batman • Star Trek 25th Anniv. • Hook		520-5050-01									
• Lethal Weapon 3		520-5050-02	520-5047-01								
• Star Wars • Rocky & Bullwinkle & Friends			520-5052-00 128 X 32								
• Jurassic Park	520-5076-00 3-Flipper	520-5047-02		520-5055-01							
• Last Action Hero	520-5070-00 2-Flipper		520-5050-03								
• Tales from the Crypt • The Who's Tommy	520-5076-00 3-Flipper		520-5077-00								
• WWF Royal Rumble	520-5070 / 5080 -00 4-Flipper (2X2)	520-5050-03	520-5047-03	520-5075-00 192 X 64	520-5092-01				520-5102-00 Single OPTO	520-5103-00 Single OPTO	Paddle Boat Wheel Enter
• Guns N' Roses	520-5076-00 3-Flipper								520-5077-00	520-5124-00 Single OPTO	520-5125-00 Single OPTO
• Maverick	520-5076-00 3-Flipper	520-5126-02	520-5124-00 Single OPTO	520-5125-00 Single OPTO	4-Ball Trough over Up-Kicker						
• Mary Shelley's Frankenstein	520-5070 / 5080 -00 4-Flipper (2X2)										
• Baywatch	520-5076-00 3-Flipper										
• Batman Forever	520-5076-00 3-Flipper										

Miscellaneous Boards (Lamp Boards & Relay Boards) not listed above can be found in each individual game manual.





APPENDIX E

Flipper Coil (White Star Board System* & S.A.M. System** Only) Table



Typical Coil Diode 1N4004 unless noted otherwise (Diode Top = above lugs next to windings; Diode Below (Bottom) = under lugs opposite of windings).

STANDARD COILS (TYPICAL APPLICATIONS)			LARGE COILS (FLIPPERS & SPECIAL APPLICATIONS)		
Ga.-Turn	Res (Ω)	SPI Part Number and Comments	Ga.-Turn	Res (Ω)	SPI Part Number and Comments
20-400	1.0 Ω	090-5021-use : -00 Diode Top	21-900	call Ω	090-5020-use : -01 3-Lugs + 1N4004 & 1N5404 Diodes -10 Diode Top <BROWN><RED>
22-500	1.7 Ω	090-5017-use : -00 Diode Top	22-750 / 30-2600	2.6 Ω 92.0 Ω	090-5011-use : -00 DUAL WND COIL // 3-Lugs Diode x2
22-600	2.2 Ω	090-5017-use : -0B Diode Below // -0T Diode Top			
23-700	3.1 Ω	090-5022-use : -0B Diode Below // -0T Diode Top	22-900	3.45 Ω	090-5020-use : -20T Diode Top <YELLOW> // -20-ND No Diode
23-750	3.4 Ω	090-5019-use : -00 Diode Top			
23-800	3.6 Ω	090-5001-use : -0B Diode Below // -0T Diode Top // -NL No Lugs 11" Leads // -ND No Diode	22-1080	4.2 Ω	090-5032-use : -0B D. Below // -0T D. Top <YEL-GRN> -NL No Diode
23-840	4.0 Ω	090-5005-use : -00 Diode Top			
23.5-765	3.6 Ω	090-5037-use : -03 Diode Top	23-620 / 30-2600	2.4 Ω 75.0 Ω	090-5006-use : -00 DUAL WND COIL // 3-Lugs Diode x2
24-900	5.0 Ω	090-5002-use : -02 Diode Top // -10 No Lugs 14" Leads			
24-940	5.5 Ω	090-5036-use : -0B Diode Below // -0T Diode Top use 090-5051-01 No Lugs 11" Leads	23-700 / 30-2600	3.0 Ω 83.5 Ω	090-5013-use : -00 DUAL WOUND COIL // Diode Top
25-1240	9.3 Ω	090-5034-use : -00 Diode Below			
26-1200	10.3 Ω	090-5044-use : -0B Diode Below // -0T Diode Top // -NL No Lugs 11" Leads // -ND No Diode	23-800 / 30-2600	2.4 Ω 90.5 Ω	090-5012-use : -00 DUAL WOUND COIL // Diode Top
27-1300	14.2 Ω	090-5003-use : -0T Diode Top			
27-1400	14.7 Ω	090-5015-use : -00 Diode Below	23-1100	5.1 Ω	090-5030-use : -0T Diode Top <ORANGE> -ND No Diode
27-1400	14.7 Ω	511-5031-00 Special App.: No Diode / Lugs + Conn.			
27-1500	16.3 Ω	090-5004-use : -0B Diode Below // -0T Diode Top	23-1200	7.1 Ω	090-5008-use : -00 Diode Top <BLACK>
29-2000	33.6 Ω	090-5016-use : -00 Diode Top	23-1500	4.4 Ω	090-5062-use : -00 Diode Top <BLUE>
LARGE, MEDIUM & MINI COILS (MAGNET APPLICATIONS)			24-1570	9.5 Ω	090-5025-use : -00 Diode Top <BLUE>
20.5-480	2.9 Ω	090-5064-use : -02 No Lugs or Core; 14" Leads // Large	25-1400	call Ω	090-5067-use : -0T Diode Top <RED>
22-650	4.3 Ω	090-5042-use : -00 No Lugs or Core; 6" Leads // Large -01 No Lugs or Core; 12" Leads // Large	25-1600	call Ω	090-5068-use : -0T Diode Top <WHITE>
24-780	8.0 Ω	090-5061-use : -00 No Lugs or Core; 6" Lds. // Medium	MINI COILS (RESET / TRIP APPLICATIONS)		
29-1000	15.2 Ω	090-5059-use : -00 Lugs + Diode + Magnet Core // Mini	27-950	call Ω	090-5046-use : -01 Diode Top
31-1500	52.0 Ω	090-5054-00 : Straight Lugs + Diode + Mag Core // Mini 090-5055-00 : 90° Lugs + Diode + Magnet Core // Mini	28-1050	11.5 Ω	090-5046-use : -00 Diode Top
Please Note: Ohm values may vary +/- .03 depending on meter calibration.			27-880	call Ω	500-6976-01 No Lugs or Diode + 6" Leads & Conn.
Ordering Note: Coils typically should not come with Coil Sleeves. IF A SLEEVE EXISTS, ensure it is the correct sleeve for the application usage. For the correct Coil Sleeve, refer to the Game Assembly Drawing the coil exists on and order separately.			31-590	call Ω	090-5010-use : -00 Diode Top
			32-1250	35.0 Ω	515-6916-01 : includes Flap & Screw <YELLOW>
			32-1800	50.2 Ω	090-5031-use : -0B Diode Below // -0T Diode Top (515-6110-00) use 515-# to include mounting & armature brackets
			33-1590	59.0 Ω	515-6916-00 : includes brackets <WHITE>

Flipper Coil (White Star Board System* Only) Table

GAME NAME	Nº of Flippers	FLIPPERS		FLIPPERS no E.O.S. Switch	
		SPI Nº / GAUGE-TURNS / Color		SPI Nº / GAUGE-TURNS / Color	
		LOWER LEFT	LOWER RIGHT	UPPER LEFT	UPPER RIGHT
Apollo 13	2	090-5032-0T 22-1080 -YEL-GRN-	SAME	Not Used	Not Used
Golden Eye	2	090-5032-0T 22-1080 -YEL-GRN-	SAME	Not Used	Not Used
Twister	2	090-5020-20T 22-900 -YELLOW-	090-5032-0T 22-1080 -YEL-GRN-	Not Used	Not Used
ID4: Independence Day	3	090-5032-0T 22-1080 -YEL-GRN-	SAME	Not Used	090-5020-30 23-900 -GREEN-
Space Jam †	2	090-5032-0T 22-1080 -YEL-GRN-	090-5020-20T 22-900 -YELLOW-	Not Used	Not Used
The Star Wars Trilogy - Special Edition †	2	090-5032-0T 22-1080 -YEL-GRN-	SAME	Not Used	Not Used
The Lost World: Jurassic Park †	2	090-5032-0T 22-1080 -YEL-GRN-	SAME	Not Used	Not Used
The X-Files †	2	090-5032-0T 22-1080 -YEL-GRN-	SAME	Not Used	Not Used
Starship Troopers †	3	090-5030-0T 23-1100 -ORANGE-	SAME	Not Used	090-5032-0T 22-1080 -YEL-GRN-
Viper Night Drivin' †	2	090-5030-0T 23-1100 -ORANGE-	SAME	Not Used	Not Used
Lost In Space †	2	090-5030-0T 23-1100 -ORANGE-	090-5032-0T 22-1080 -YEL-GRN-	Not Used	Not Used
Godzilla †	2	090-5032-0T 22-1080 -YEL-GRN-	SAME	Not Used	Not Used
South Park †	2	090-5030-0T 23-1100 -ORANGE-	SAME	Not Used	Not Used

† Coil Part Numbers ending with a "T" signifies the Diode is on the top of the lug (on the coil-winding side); Coil Part Numbers ending with a "B" signifies the Diode is on the bottom of the lugs.

Table continued on the next page.





APPENDIX E

Flipper Coil (White Star Board System* & S.A.M. System** Only) Table



GAME NAME	N ^o of Flippers	FLIPPERS w/E.O.S. Switch		FLIPPERS no E.O.S. Switch	
		SPI N ^o / GAUGE-TURNS / Color		SPI N ^o / GAUGE-TURNS / Color	
		LOWER LEFT	LOWER RIGHT	UPPER LEFT	UPPER RIGHT
Harley-Davidson® † and 1st through 3rd Editions	2	090-5032-0T 22-1080 -YEL-GRN-	090-5030-0T 23-1100 -ORANGE-	Not Used	Not Used
Striker Xtreme (NFL) †	3	090-5032-0T 22-1080 -YEL-GRN-	090-5030-0T 23-1100 -ORANGE-	090-5030-0T 23-1100 -ORANGE-	Not Used
Sharkey's Shootout †	3	090-5030-0T 23-1100 -ORANGE-	SAME	090-5030-0T 23-1100 -ORANGE-	Not Used
High Roller Casino †	2	090-5032-20T 22-900 -YELLOW-	090-5032-0T 22-1080 -YEL-GRN-	Not Used	Not Used
Austin Powers™ †	2	090-5020-30 23-900 -GREEN-	090-5030-0T 23-1100 -ORANGE-	Not Used	Not Used
MONOPOLY® †	3	090-5032-0T 22-1080 -YEL-GRN-	SAME	Not Used	090-5062-0T 23-1500 -BLUE-
Playboy †	2	090-5030-0T 23-1100 -ORANGE-	SAME	Not Used	Not Used
RollerCoaster Tycoon™ †	4	090-5032-0T 22-1080 -YEL-GRN-	SAME	090-5067-0T 25-1400 -RED-	090-5068-0T 25-1600 -WHITE-
The Simpsons™ Pinball Party †	6** (5 with Flipper Bats)	090-5032-0T 22-1080 -YEL-GRN-	SAME	Not Used	090-5030-0T 23-1100 -ORANGE-
		** The Homer Head Assembly is affixed to an Upr. Rt. Style Flipper (no E.O.S. Switch):		Flippers (Mini-Bats) on 2nd Level Playfield:	
			** 090-5020-20T 22-900 -YELLOW-	090-5041-00T 25-1800 -BLU-GRN-	090-5025-00 24-1570 -BLUE-
Terminator® 3: Rise of the Machines™ †	2	090-5032-0T 22-1080 -YEL-GRN-	SAME	Not Used	Not Used
The Lord of the Rings™ †	2	090-5020-20T 22-900 -YELLOW-	SAME	Not Used	Not Used
Ripley's Believe It or Not!® †	3	090-5032-0T 22-1080 -YEL-GRN-	SAME	Not Used	090-5067-00T 25-1400 -RED-
Elvis® †	4	090-5020-20T 22-900 -YELLOW-	SAME	090-5020-30 23-900 -GREEN-	SAME
The Sopranos™ †	2	090-5032-0T 22-1080 -YEL-GRN-	SAME	Not Used	Not Used
NASCAR® and [NDSE] †	2	090-5030-0T 23-1100 -ORANGE-	SAME	Not Used	Not Used
Grand Prix †	2	090-5030-0T 23-1100 -ORANGE-	SAME	Not Used	Not Used
† Coil Part Numbers ending with a "T" signifies the Diode is on the top of the lug (on the coil-winding side); Coil Part Numbers ending with a "B" signifies the Diode is on the bottom of the lugs.					
** S.A.M. System Games DO NOT REQUIRE DIODES. If you use a coil from your stock which has a diode, remove it ONLY FOR S.A.M. System Games.					
World Poker Tour™ (WPT)**	4	090-5032-ND 22-1080 [NO DIODE]	SAME	090-5030-ND 23-1100 [NO DIODE]	SAME
©Disney's Pirates of the Caribbean**	2	090-5030-ND 23-1100 [NO DIODE]	SAME	Not Used	Not Used
Family Guy™ **	3 Norm.	090-5030-ND 23-1100 [NO DIODE]	SAME	090-5062-ND 23-1500 [NO DIODE]	Not Used
	2 Mini	090-5046-01-ND 27-950 [NO DIODE]	SAME		
Spider-Man™ **	3	090-5032-ND 22-1080 [NO DIODE]	SAME	Not Used	090-5032-ND 22-1080 [NO DIODE]



APPENDIX E

Generic Coil Cross-Reference Guide † ‡

Flipper Coil Table ‡ ††

GAME NAME	Nº of Flippers	FLIPPERS w/E.O.S. Switch		FLIPPERS no E.O.S. Switch	
		SPI Nº / GAUGE-TURNS / Color		SPI Nº / GAUGE-TURNS / Color	
		LOWER LEFT	LOWER RIGHT	UPPER LEFT	UPPER RIGHT
Laser War ‡	2	090-5011-00 22-750 / 30-2600	SAME	Not Used	Not Used
Secret Service ‡	3	090-5006-00 23-620 / 30-2600	SAME	Not Used	090-5006-00 23-620 / 30-2600
Torpedo Alley ‡	3	090-5011-00 22-750 / 30-2600	090-5013-00 23-700 / 30-2600	Not Used	090-5012-00 23-800 / 30-2600
Time Machine ‡	2	090-5011-00 22-750 / 30-2600	SAME	Not Used	Not Used
‡ These coils are dual-wound.					
Playboy 35th Anniversary ††	2	090-5020-02 22-900 -YEL-YEL-	SAME	Not Used	Not Used
ABC Monday Night Football ††	2	090-5020-02 22-900 -YEL-YEL-	SAME	Not Used	Not Used
†† A very small % of these games used a 090-5020-20 coil which used a proto-type Solid State Flipper System. The two types of coils both are 22-900 coils; the only difference is the addition of the 1N5404 Diode on the (-02) coils which was used in the Deger Design.					
Robocop	2	090-5020-20 22-900 -YEL-YEL-	SAME	Not Used	Not Used
Phantom of the Opera	2	090-5020-20 22-900 -YEL-YEL-	SAME	Not Used	Not Used
Back to the Future	2	090-5020-20 22-900 -YEL-YEL-	SAME	Not Used	Not Used
The Simpsons	2	090-5020-20 22-900 -YEL-YEL-	SAME	Not Used	Not Used
Checkpoint	2	090-5020-20 22-900 -YEL-YEL-	SAME	Not Used	Not Used
Teenage Mutant Ninja Turtles	2	090-5020-30 23-900 -GRN-GRN-	SAME	Not Used	Not Used
Batman	2	090-5020-30 23-900 -GRN-GRN-	SAME	Not Used	Not Used
Star Trek 25th Anniversary	2	090-5020-30 23-900 -GRN-GRN-	SAME	Not Used	Not Used
Hook	2	090-5030-00 23-1100 -ORG-ORG-	090-5020-30 23-900 -GRN-GRN-	Not Used	Not Used
Lethal Weapon 3	2	090-5030-00 23-1100 -ORG-ORG-	SAME	Not Used	Not Used
Star Wars	2	090-5032-00 22-1080 -YEL-GRN-	SAME	Not Used	Not Used
Rocky & Bullwinkle & Friends	2	090-5020-30 23-900 -GRN-GRN-	SAME	Not Used	Not Used
Jurassic Park	3	090-5020-30 23-900 -GRN-GRN-	SAME	Not Used	090-5030-00 23-1100 -ORG-ORG-

Table continued on the next page.



APPENDIX E

Flipper Coil Table †

GAME NAME	N ^o of Flippers	FLIPPERS w/ E.O.S. Switch		FLIPPERS no E.O.S. Switch	
		SPI N ^o / GAUGE-TURNS / Color		SPI N ^o / GAUGE-TURNS / Color	
		LOWER LEFT	LOWER RIGHT	UPPER LEFT	UPPER RIGHT
Last Action Hero	2	090-5020-30 23-900 -GRN-GRN-	SAME	Not Used	Not Used
Tales from the Crypt	3	090-5032-00 22-1080 -YEL-GRN-	SAME	Not Used	090-5041-00 25-1800 -BLU-GRN-
The Who's Tommy	3	090-5020-30 23-900 -GRN-GRN-	SAME	090-5041-00 25-1800 -BLU-GRN-	Not Used
WWF Royal Rumble	4	090-5032-00 22-1080 -YEL-GRN-	SAME	090-5041-00 25-1800 -BLU-GRN-	SAME
Guns N' Roses	3	090-5032-00 22-1080 -YEL-GRN-	SAME	090-5030-00 23-1100 -ORG-ORG-	Not Used
Maverick	3	090-5032-00 22-1080 -YEL-GRN-	SAME	Not Used	090-5032-00 22-1080 -YEL-GRN-
Mary Shelley's Frankenstein	3	090-5030-00 23-1100 -ORG-ORG-	SAME	Not Used	090-5030-00 23-1100 -ORG-ORG-
Baywatch	4	090-5030-00 23-1100 -ORG-ORG-	090-5020-30 23-900 -GRN-GRN-	090-5025-00 24-1570 -See Note-	090-5030-00 23-1100 -ORG-ORG-
Batman Forever	3	090-5032-00 22-1080 -YEL-GRN-	090-5020-20 22-900 -YEL-YEL-	Not Used	090-5020-30 23-900 -GRN-GRN-
Apollo 13	2	090-5032-00 22-1080 -YEL-GRN-	SAME	Not Used	Not Used
Golden Eye	2	090-5032-00 22-1080 -YEL-GRN-	SAME	Not Used	Not Used
Twister	2	090-5020-20 22-900 -YEL-YEL-	090-5032-00 22-1080 -YEL-GRN-	Not Used	Not Used
ID4: Independence Day	3	090-5032-00 22-1080 -YEL-GRN-	SAME	Not Used	090-5020-30 23-900 -GRN-GRN-
Space Jam †	2	090-5032-00T 22-1080 -YEL-GRN-	090-5020-20T 22-900 -YEL-YEL-	Not Used	Not Used
The Star Wars Trilogy - Special Edition †	2	090-5032-00T 22-1080 -YEL-GRN-	SAME	Not Used	Not Used
The Lost World: Jurassic Park †	2	090-5032-00T 22-1080 -YEL-GRN-	SAME	Not Used	Not Used
The X-Files †	2	090-5032-00T 22-1080 -YEL-GRN-	SAME	Not Used	Not Used
Starship Troopers †	3	090-5030-00T 23-1100 -ORG-ORG-	SAME	Not Used	090-5032-00T 22-1080 -YEL-GRN-
Viper Night Drivin' †	2	090-5030-00T 23-1100 -ORG-ORG-	SAME	Not Used	Not Used
Lost In Space †	2	090-5030-00T 23-1100 -ORG-ORG-	090-5032-00T 22-1080 -YEL-GRN-	Not Used	Not Used
Godzilla †	2	090-5032-00T 22-1080 -YEL-GRN-	SAME	Not Used	Not Used
South Park †	2	090-5030-00T 23-1100 -ORG-ORG-	SAME	Not Used	Not Used
Harley-Davidson® † and Harley-Davidson® 2nd Ed. †	2	090-5032-00T 22-1080 -YEL-GRN-	090-5030-00T 23-1100 -ORG-ORG-	Not Used	Not Used
Striker Xtreme (NFL) †	3	090-5032-00T 22-1080 -YEL-GRN-	090-5030-00T 23-1100 -ORG-ORG-	090-5030-00T 23-1100 -ORG-ORG-	Not Used
Sharkey's Shootout †	3	090-5030-00T 23-1100 -ORG-ORG-	SAME	090-5030-00T 23-1100 -ORG-ORG-	Not Used
High Roller Casino †	2	090-5020-20T 22-900 -YEL-YEL-	090-5032-00T 23-1080 -YEL-GRN-	Not Used	Not Used
Austin Powers™ †	2	090-5020-30 23-900 -GRN-GRN-	090-5030-00T 23-1100 -ORG-ORG-	Not Used	Not Used
MONOPOLY® †	3	090-5032-00T 22-1080 -YEL-GRN-	SAME	Not Used	090-5062-00T 23-1500 -BLU-BLU-
Playboy †	2	090-5030-00T 23-1100 -ORG-ORG-	SAME	Not Used	Not Used
RollerCoaster Tycoon™ †	4	090-5032-00T 22-1080 -YEL-GRN-	SAME	090-5067-00T 25-1400 -RED-RED-	090-5068-00T 25-1600 -WHT-WHT
The Simpsons™ Pinball Party †	6* (5 with Flipper Bats)	090-5032-00T 22-1080 -YEL-GRN-	SAME	Not Used	090-5030-00T 23-1100 -ORG-ORG-
		* The Homer Head Assembly is affixed to an Upr. Rt. Style Flipper (no E.O.S. Switch):		Flippers (Mini-Bats) on 2nd Level Playfield:	
			* 090-5020-20T 22-900 -YEL-YEL-	090-5041-00T 25-1800 -BLU-GRN-	090-5025-00T 24-1570 -See Note-
Terminator® 3: Rise of the Machines™ †	2	090-5032-00T 22-1080 -YEL-GRN-	SAME	Not Used	Not Used
The Lord of the Rings™ †	2	090-5020-20T 22-900 -YEL-YEL-	SAME	Not Used	Not Used
Ripley's Believe It or Not!® †	3	090-5032-00T 22-1080 -YEL-GRN-	SAME	Not Used	090-5067-00T 25-1400 -RED-RED-

† Coil Part N^os ending with a "T" signifies the Diode is on the top of the lug (on the coil-winding side); Coil Part N^os ending with a "B" signifies the Diode is on the bottom of the lugs.



APPENDIX F

Motor Specification (White Star Board System* Only) Table



Game Name	Function	Specifications	Part Number
Apollo 13	Rocket Up/Down Movement	Bowman Motor 24VAC 60Hz 3W 6 RPM CCW	515-6383-00 <i>incl. Connector</i>
	Moon Unit Rotational Orbit	Multi Products Motor 24VAC 50/60Hz 3W 6 RPM CCW	515-6487-00 <i>incl. Connector</i>
	Shaker	Johnson Motor (Vibrator) 10.5VDC 10 AMP 2950 RPM CW	041-5029-00 MOTOR ONLY
Golden Eye	Satellite Left/Right Movement	Bowman Motor 24VAC 60Hz 3W 6 RPM CW	515-6528-00 <i>incl. Connector</i>
Twister	Spinning Disc with Magnet	Multi Products Motor 24VAC (041-5026-00) 50/60Hz 3W 325 RPM CCW	515-6347-00 <i>incl. Connector</i>
	Backbox Fan (Tornado Wind)	Multi Products Motor 24VAC (041-5052-00) 50/60Hz 3W 3600 RPM CW	515-6531-00 <i>incl. Connector</i>
ID4: Independence Day	Alien Head Open/Close Movement	Servo Motor (94322)	041-5045-00 MOTOR ONLY
<i>SPACE JAM (NO MOTOR USED)</i>			
The Star Wars Trilogy - S.E.	X-Wing Left/Right Movement	Bowman Motor 24VAC (041-5058-00) 60Hz 3W 10 RPM CCW	515-6383-01 <i>incl. Connector</i>
The Lost World: Jurassic Park	Snagger & Center Link Lift Up/Down Movement	Multi Products Motor 20VDC (041-5059-03) 9 RPM Non-Directional	515-6715-03 <i>incl. Connector</i>
	Shaker	Johnson Motor (Vibrator) 10.5VDC 10 AMP 2950 RPM CW	041-5029-00 MOTOR ONLY
The X-Files	X-File Cabinet Lift Up/Down Movement	Multi Products Motor 20VDC 9 RPM CCW	041-5057-00 MOTOR ONLY
Starship Troopers	Warrior Bug Forward/Reverse Movement	Haydon Switch & Instrument, Inc. Stepper Motor 12VDC 4.6W (041-5062-00), Series 36000: 1.4"ø (Non-Captive Shaft not included) HSI #36864-12 (Unipolar) Travel per Step: .004 Step Angle: 15°	515-6794-00 <i>incl. Connector</i> Requires 7" Shaft: 530-5503-00
<i>VIPER NIGHT DRIVIN' (NO MOTOR USED)</i>			
Lost In Space	Spinning Disc with Magnet	Multi Products Motor 24VAC (041-5046-00) 50/60Hz 3W 325 RPM CCW	515-6347-00 <i>incl. Connector</i>
Godzilla	Shaker ‡	Multi #3811 0630 Motor (Vibrator) 12VDC 3100 RPM CW (w/DRL PTS) ‡	041-5029-01 MOTOR ONLY
<i>SOUTH PARK (NO MOTOR USED)</i>			
Harley-Davidson® 1st through 3rd Editions	Shaker ‡	Multi #3811 0630 Motor (Vibrator) 12VDC 3100 RPM CW (w/DRL PTS) ‡	041-5029-01 MOTOR ONLY
	Motorcycle Lift Up/Down Movement	Autotrol 24VAC (041-5072-02) 20 RPM CCW	515-7025-00 <i>incl. Connector</i>
Striker Xtreme (NFL)	Goalie (Linebacker) Left to Right Movement	Multi #3590 12VDC (041-5075-00) 60 RPM	515-7071-00 <i>incl. Connector</i>
Sharkey's Shootout	Mystery Ball Rotating Movement	Hankscraft Motor Model-E 24VAC (041-5076-00) 50/60Hz 3W 20 RPM CW	515-7095-00 <i>incl. Connector</i>
High Roller Casino	Roulette Wheel Rotating Movement	Multi Products Motor 20VDC (041-5078-00) 17 RPM CCW	515-7153-00 <i>incl. Connector</i>
	Up/Dn. Ramp in Slot Mach. Lift Up/Down Movement	Haydon Switch & Instrument, Inc. Stepper Motor 12VDC 4.6W (041-5062-00), Series 36000: 1.4"ø (Non-Captive Shaft not included) HSI #36864-12 (Unipolar) Travel per Step: .004 Step Angle: 15°	515-6794-00 <i>incl. Connector</i> Requires Shaft ¾": 530-5503-01
Austin Powers™	Time Machine Rotating Movement	Multi Products Motor 24VAC (041-5079-00) 50/60Hz 20RPM CCW	515-7141-00 <i>incl. Connector</i>
	Laser Beam Left to Right Directional	Autotrol Motor 24VAC (041-5081-00) 50/60Hz 4W 10RPM Bi-Directional	515-7171-00 <i>incl. Connector</i>
	Dr. Evil Target Lift Up/Down Movement	Hankscraft Motor Model-E 24VAC (041-5030-00) 50/60Hz 6RPM CCW	515-5900-00 <i>incl. Connector</i>
Monopoly®	Mini-Flipper (Waterworks) Rotating Movement	Multi Prod. Motor & Gear Box #7000 EX00159A 20VDC 50/60Hz 85RPM CC/CCW	041-5083-00 MOTOR ONLY
Playboy	Triangular Billboard Rotating Movement	Autotrol Motor (BD511 150-1387) 24VAC 50/60Hz 12RPM Bi-Directional	041-5086-02 MOTOR ONLY
	Centerfold Mechanism Open/Close Movement	Multi Products (3680) Motor 12v DC 10/12 RPM CC/CCW	041-5075-04 MOTOR ONLY
	Tease Drop Screen Lift Up/Down Movement	Haydon Switch & Instrument, Inc. Stepper Motor 12VDC 4.6W (041-5062-00), Series 36000: 1.4"ø (Non-Captive Shaft not included) HSI #36864-12 (Unipolar) Travel per Step: .004 Step Angle: 15°	515-6794-00 <i>incl. Connector</i> Requires 7" Shaft: 530-5503-00

‡ Please Note: "01" Shaker Motor is **Not Compatible** with old Shaker Motor 041-5029-00 (Shaker Motor Assy. 515-5893-00). THIS NEW MOTOR CAN ONLY BE USED IN NEW SHAKER MOTOR ASSY. 515-5893-01.

Table continued on the next page.





APPENDIX F

Motor Specification (White Star Board System* & S.A.M. System** Only) Table



Game Name	Function	Specifications	Part Number
ROLLERCOASTER TYCOON™ (NO MOTOR USED)			
THE SIMPSONS™ PINBALL PARTY (NO MOTOR USED)			
Terminator® 3: Rise of the Machines™	Backbox Ball Shooter Up/Down Movement	Multi Products Motor 24VAC (041-5079-01) 21 RPM CW	515-7317-00 <i>incl. Connector</i>
The Lord of the Rings™	Balrog (Motor & Gate) Open/Close Movement	Multi Prod. Motor 20VDC Series 600B (or equiv.) 50/60Hz 10 RPM Bi-Directional	041-5088-01 MOTOR ONLY
RIPLEY'S BELIEVE IT OR NOT!® (NO MOTOR USED)			
Elvis®	Elvis™ Front/Back Movement	Haydon Switch & Instrument, Inc. Stepper Motor 12VDC 10W (041-5089-00), (Non-Captive Shaft not included) HSI #46868-12-002	500-6809-00 <i>incl. Connector</i> Requires 7.25" Shaft: 530-5658-00
	▶▶▶ OPTIONAL ◀◀◀ Shaker	Multi #3811 0630 Motor (Vibrator) 12VDC (041-5029-01) 3100 RPM (w/DRL PTS)	515-5893-01 <i>incl. Connector</i>
The Sopranos™	Bada Bing! Girls x2 Rotating Posts Movement	Autotrol Synchronous Motor 24VAC 4W 50/60Hz 45.7/54.9 RPM Bi-Directional	041-5092-00 <i>w/1" Shaft + 12" Leads</i>
NASCAR® and [NDSE]	Back Panel Rotating (Car) Windmill (Skill Ball Enter)	Multi Products Motor & Gear Box 20VDC Model #8000 (EX-04-073) 10 RPM	041-5093-00 MOTOR ONLY
Grand Prix	Back Panel Rotating (Car) Windmill (Skill Ball Enter)	Multi Products Motor & Gear Box 20VDC Model #8000 (EX-04-073) 10 RPM	041-5093-00 MOTOR ONLY
World Poker Tour™ (WPT) (NO MOTOR USED)			
The Simpsons™ Kooky Carnival	Bart on Skateboard Left/Right Movement	Multi Products Motor with Crank 24VAC (041-5095-01) 50/60Hz 3W 14 RPM	500-6947-01 <i>incl. Connector</i>
	Left & Right Ramps Up/Down Movement	Multi Products Motor 24VAC (041-5048-01) 50/60Hz 3W 15 RPM CCW (Qty. 2 in game)	515-7558-00 <i>incl. Connector</i>
	Shaker <i>(details in SKC Manual, Page 24)</i>	Multi #3811 0630 Motor (Vibrator) 12VDC 3100 RPM (w/DRL PTS)	041-5029-01 MOTOR ONLY
©Disney's Pirates of the Caribbean	Spinning Disk	Multi #3811R 0630 Motor (Vibrator) 12VDC (041-5029-04) 3100 RPM (w/DRL PTS) -04 is RoHS compliant; can substitute with -01 domestic	511-5024-04 <i>incl. Connector</i>
	Pirate Ship Sinking/Raising Movement	Multi Products Motor & Gear Box 24VDC Model #7000-DCM 12 RPM	041-5101-00 MOTOR ONLY
Family Guy™	Stewie Figurine Left & Right Movement	Stepper Motor NPM PF35T-48D4STD 5V RVB (041-5102-00 Reference Only)	511-5043-00 <i>incl. Connector</i>
Spider-Man™	Doc Ock, Sandman & 3-Bank Up/Down Movement	Sync. Motor 24VAC 50/60Hz 3W 12 RPM CW (041-5103-00 Reference Only)	511-5063-00 <i>incl. Connector</i>
	▶▶▶ OPTIONAL ◀◀◀ Shaker Motor Kit 502-5027-00	Multi #3811R 0630 Motor (Vibrator) 12VDC (041-5029-04) 3100 RPM (w/DRL PTS) -04 is RoHS compliant; can substitute with -01 domestic	515-5893-01 <i>incl. Connector</i>



APPENDIX F

Motor Specification Table

The following table only list games that used motors. Part Numbers starting with "515-" will include the Wiring Harness & Connector.

Game Name	Function	Specifications	Part N ^o
ABC Monday Night Football	Goal Post Up/Down Movement	Motor 24v A.C. 60 RPM CW	515-5222-00
Phantom of the Opera	Organ Up/Down Movement	Bowman Motor 24v 60Hz 3W 11 RPM CCW	515-5256-00
Checkpoint	Mag Wheel (in Backbox)	Motor D.C. (KEN)	041-5005-00
	Shaker	Johnson Motor (Vibrator)	041-5002-00
Teenage Mutant Ninja Turtles	Spinning Pizza Ball Deflector	Gear Motor 24v A.C. 325 RPM CW	515-5397-00
Batman	Bar Target Up/Down Movement	Bowman Motor 24v 60Hz 3W 11 RPM CCW	515-5256-00
Star Trek 25th Anniversary	Swinging Target	Bowman Motor 24v 22½ RPM	515-5534-00
	Transporter F/X	Gear Motor 24v A.C. 3½ RPM	500-5421-00
	Cooling Fan (for Transporter F/X)	4½" Motor 12v	041-5014-00
Lethal Weapon 3	Spinning Light	Motor 2½ v A.C. 4000 RPM CCW	041-5017-00
Star Wars	Bar Target Up/Down Movement	Bowman Motor 24v 60hz 3W 11 RPM CCW	515-5256-00
	R2D2 Robot Left/Right Movement	Bowman Motor 24v A.C. 22½ RPM CW	515-5571-00
	Death Star Rotation	Bowman "G" Motor 24v A.C. 60Hz 6 RPM CW	515-5570-00
Rocky & Bullwinkle & Friends	Nell Log "Cutting Blade" Forward/Back Movement	Autotrol Model E Motor 24v 60hz 4W 3 RPM CCW	041-5023-00
Jurassic Park	T-Rex Left/Right Movement	Multi Motor 5v D.C.	041-5025-00
	T-Rex Up/Down Movement	Bowman Motor 24v 11 RPM CW	041-5026-00
	Shaker	Johnson Motor (Vibrator)	041-5002-00
Last Action Hero	Crane Left/Right Movement	Multi Products Motor 12v D.C. #3312 OSC	041-5027-00
	Shaker	Johnson Motor (Vibrator) 10.5v D.C. 10 AMP 2950 RPM CW	041-5029-00
Tales from the Crypt	Tombstone Up/Down Movement	Bowman Motor 24v A.C. 6 RPM CCW	515-5900-00
	Shaker	Johnson Motor (Vibrator) 10.5v D.C. 10 AMP 2950 RPM CW	041-5029-00
The Who's Tommy	Mirror Up/Down Movement	Bowman Motor 24v A.C. 6 RPM CCW	515-5900-00
	Flipper Blinders	Servo Motor (94102)	041-5032-00
	Spinning Airplane Propellers	Motor D.C.	041-5033-00
WWF Royal Rumble	Shaker	Johnson Motor (Vibrator) 10.5v D.C. 10 AMP 2950 RPM CW	041-5029-00
Maverick, The Movie	Turning Paddle Wheel	Motor 24v A.C. 10 RPM	041-5036-00
Mary Shelley's Frankenstein	Creature Head Left/Right Movement	Servo Motor (94102)	041-5032-00
Batman Forever	Cannon Left/Right Movement	Bowman Motor 24v A.C. 60Hz 3W 6 RPM CCW	515-6383-00

APPENDIX G

Part Number Prefix Classification Codes

I. Electrical Source, Energy & Signal Converters

- 010- Transformers
- 031- Speakers
- 090- Solenoids (Coils)
- 150- Filters, Outlets, Varistors, Thermistors
- 200- Fuses

II. Conductors, Connectors & Insulators

- 034- Line Cords
- 036- Cable Assemblies & Wiring Harnesses
- 041- Motors
- 045- Connectors (All Types)
- 055- Lugs (M/F), Pins (M/F), Discs, Ring Terminals, Terminal Strips, etc.
- 060- Polarizing Keys and Conn. Covers
- 077- Lamp Sockets

III. Circuits & Circuit Elements

- 100- ICs
- 110- Transistors
- 112- Diodes (All Types including LEDs & Modules)
- 121- Resistors
- 123- Resistors (Variable & Adjustable)
- 124- Regulators & Bridge Rectifiers
- 125- Capacitors (Radial Lytics & Ferrites)
- 126- Piezo Crystal
- 127- Heatsinks
- 130- Capacitors (Tectates & Ceramics)
- 140- Oscillators (Clocks/Crystals)
- 165- Light Bulbs
- 180- Switches
- 181- Switch Membranes (Pads) & Piezo Sensors
- 190- Relays
- 960- EPROM (*Raw Part*)
- 965- EPROM (*Programmed Part*)

IV. Bolts, Screws, Nuts, Washers & Nails

- 231- Bolts
- 232- Screws (Pan Head)
- 234- Screws (HWH)
- 237- Screws (Misc.)
- 240- Nuts (Misc.)
- 242- Washers (Flat, Round)
- 244- Washers (Split Lock)
- 245- Nyloners
- 246- Washers (Lockers, External Tooth)
- 281- Nails

V. Mechanical Components

- 249- Rivets
- 251- Pins (Dowel), Finishing Nails, Hairpins, Spring Pins and Clevis Pins
- 254- Stand-Offs, Spacers and Shims
- 260- Steel Ball (All Types Steel, Glowing, Delrin, etc.)
- 265- Springs (Extension)
- 266- Springs (Compression)
- 267- Springs (Torsion)
- 269- Springs (Washers - Belleville, Wave)
- 270- Retaining Rings
- 280- Grommets, Bushings and Nyloners
- 283- Bearings

VI. Handles, Locks, Catches, Latches, Keys

- 355- Handles, Locks, Catches, Latches and Keys

VII. Fabricated Parts

- 390- Hinges
- 501- Coin Doors
- 515- Sub-Assemblies
- 520- Printed Circuit Boards (PCBs)
- 522- Display Glass
- 525- Wood Parts
- 530- Screw Machined Parts
- 535- Fabricated Parts
- 545- Molded (Extruded) Plastic and Rubber Parts (Rings, Sleeves, etc.)
- 550- Molded (Inserts)

VIII. In-House Assemblies

- 500- End Product (Systems and Models)
- 502- Kits (Created In-House)
- 505- Cabinets (complete)
- 510- Riveted Sub-Assemblies (In-House)
- 511- Sub-Assemblies (In-House)
- 515- Sub-Assemblies*

*2 or more 515-'s but still a sub-assembly.

IX. Bulk Materials

- 600- Braided Wire & Ground Straps
- 601- Stranded Wire
- 602- Ribbon Cable
- 604- Telephone Line Cord
- 605- Sleeving (Shrink Tubing)
- 625- Velcro (non-adhesive)
- 626- Foam Rubber, Foam Pads, Rubber Bumpers (Blue Pads), Tape (All Types) Velcro (adhesive) and String / Rope















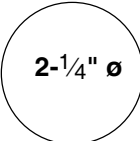
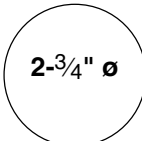
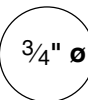
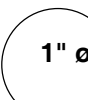
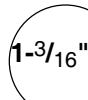
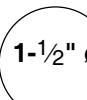
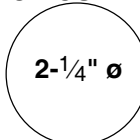
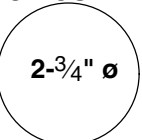

X. Miscellaneous

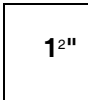
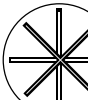
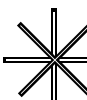
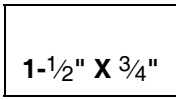
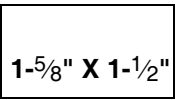
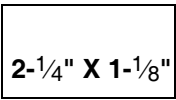
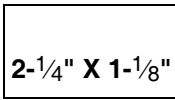
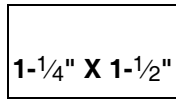
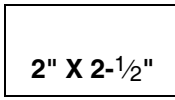
- 000- Tools (*see also 777-*) and Supplies
- 040- Clamps, Ties & Clips
- 042- Pulleys
- 091- Coin Mechs
- 205- Fuse Holders
- 631- Staples
- 660- Glass (Playfield, Backglass, etc.)
- 675- Cleaners
- 705- Packing & Shipping Items
- 755- Instruction, Coin Cards, Ins. Sheets
- 756- Information Sheets, Service Bulletins, Instruction Sheets in Kits and Templates
- 777- Tools (Wrenches and Drivers)
- 780- Manuals
- 802- Decal Kits (comprised of 820's)
- 820- Decals, Mylar and Labels (Sheets/Sets)
- 803- Plastic Kits (comprised of 830's)
- 830- Plastic Pieces (Butyrate Sheets/Sets)
- 880- Toys, Models, Figurines, etc.
- 900- Game Posters

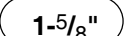
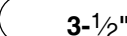

APPENDIX H

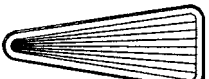
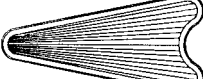
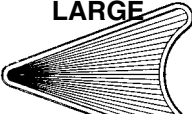
Playfield Inserts (Plastic Light Covers)

Patterns: STARBURST  STIPPLE 	STARBURST CIRCULAR  550-5000-XX	STARBURST CIRCULAR  550-5001-XX	STARBURST CIRCULAR  550-5002-XX	STARBURST CIRCULAR  550-5003-XX	STARBURST CIRCULAR  550-5004-XX
STARBURST CIRCULAR  550-5005-XX	STARBURST CIRCULAR  550-5006-XX	PLAIN CIRCULAR  550-5007-XX	PLAIN CIRCULAR  550-5008-XX	PLAIN CIRCULAR  550-5009-XX	PLAIN CIRCULAR  550-5010-XX
PLAIN CIRCULAR  550-5011-XX	PLAIN CIRCULAR  550-5012-XX	STIPPLE CIRCULAR  550-5048-XX	STIPPLE 1" SQUARE  550-5019-XX	ROLLOVER BUTTON BASE  550-5026-XX	WHITE STAR (only in white)  545-5015-00
STIPPLE RECTANGULAR  550-5018-XX	STIPPLE RECTANGULAR  550-5051-XX	STARBURST RECTANGULAR  550-5044-XX	PLAIN RECTANGULAR  550-5049-XX	PLAIN RECTANGULAR  550-5050-XX	PLAIN RECTANGULAR  550-5063-XX
STARBURST MINI SHIELD  550-5024-XX	STARBURST LARGE SHIELD  550-5025-XX	MINI HOT DOG  550-5020-XX	BEVEL HOT DOG  550-5021-XX	PLAIN HOT DOG  550-5022-XX	BANANA  550-5023-XX
STARBURST ARROW-SMALL  550-5013-XX	STARBURST ARROW-LARGE  550-5070-XX	STARBURST ARROW-HEAD SMALL  550-5014-XX	STARBURST ARROW-HEAD LARGE  550-5015-XX	STARBURST BULLET  550-5016-XX	STARBURST TRIANGLE  550-5017-XX

Note: The shapes and sizes shown above are not to scale. Some shapes may no longer be available in every color.

Instructions: Parts which may come in various colors (i.e. targets, some posts, playfield inserts, etc.) end in a 2-digit number which correspond to the color of that part. The "-XX" in part number which may come in various colors should be replaced with the desired 2-Digit number corresponding to the color desired below. *Not all colors may be available.*

PLASTIC PART COLOR CHART											
Nº	Color	Nº	Color	Nº	Color	Nº	Color	Nº	Color	Nº	Color
-00	Black or Solid Clear	-03	Amber	-06	Yellow	-09	Purple	-12	Fluor. Blue	-15	Luminescent
-01	Clear	-04	Green	-07	Orange	-10	Fluor. Orange	-13	Teal Green	-16	Gold
-02	Red	-05	Blue	-08	White	-11	Fluor. Green	-14	Gray	-17	Trans. Brown

APPENDIX I

Anti-Loft Stand-Up Targets

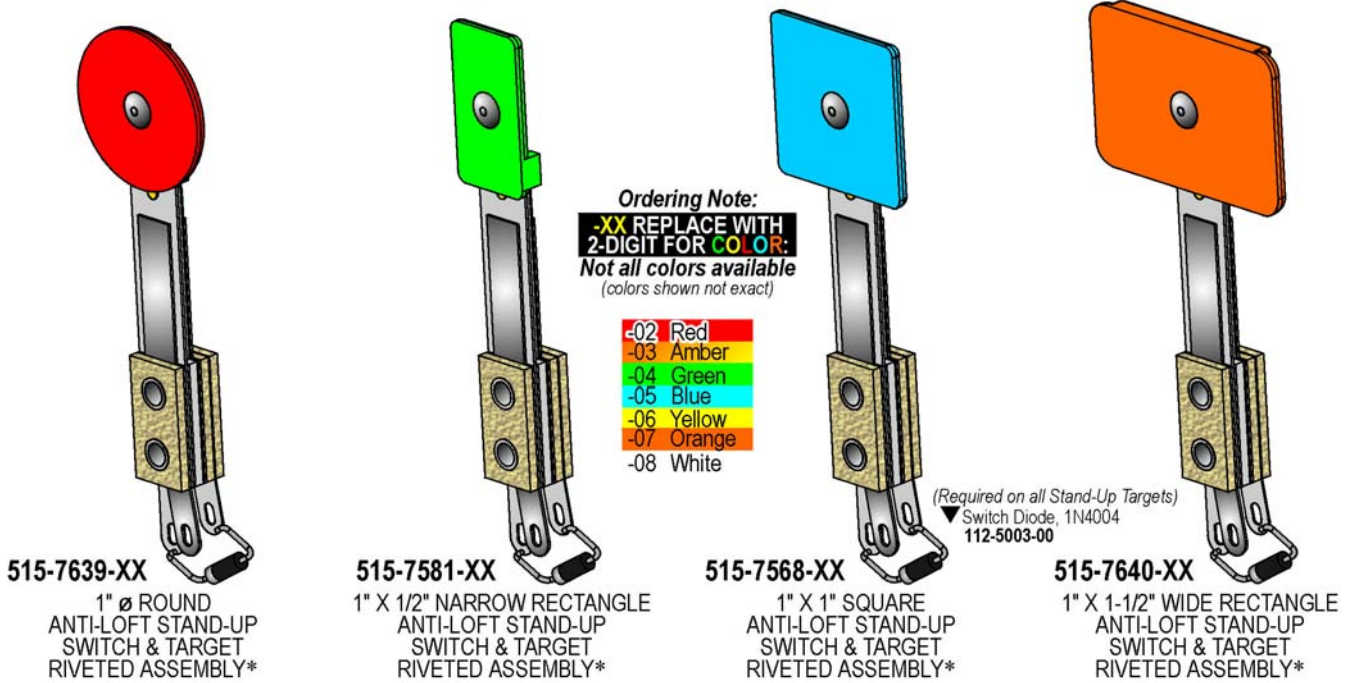

*Some targets may require the lugs position be changed to the left or to the right, depending on the application; these targets will have a different part number and are called out in the game manual they are used in (see Section 4, Chapter 1, Parts Identification & Location, Playfield ... -Switches.) Review the game manual for the game desired for the original target used or application.

For Anti-Loft Application use
 Large Foam Pad,
 5/8" X 7/16" X 3/16" Thick
626-5078-00

For > Light < Anti-Loft Application use
 Small Foam Pad,
 7/16" X 7/16" X 1/8" Thick
626-5029-00

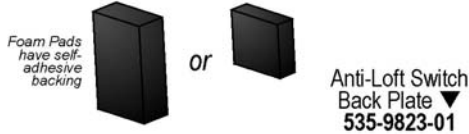

ASM. REF. IN-HOUSE USE ONLY:
Light Anti-Loft Stand-Up Target Assemblies which includes the Anti-Loft Switch Back Plate, Switch Mounting Bracket and Foam Pad (Small): 500-5835-XX (ROUND), 500-5857-XX (NARROW), 500-5232-XX (SQUARE) and 500-5321-XX (RECTANGLE).

Anti-Loft Stand-Up Target Assemblies which includes the Anti-Loft Switch Back Plate, Switch Mounting Bracket and Foam Pad (Large): 500-7082-XX (ROUND), 500-6985-XX (NARROW), 500-6984-XX (SQUARE) and 500-7063-XX (RECTANGLE).

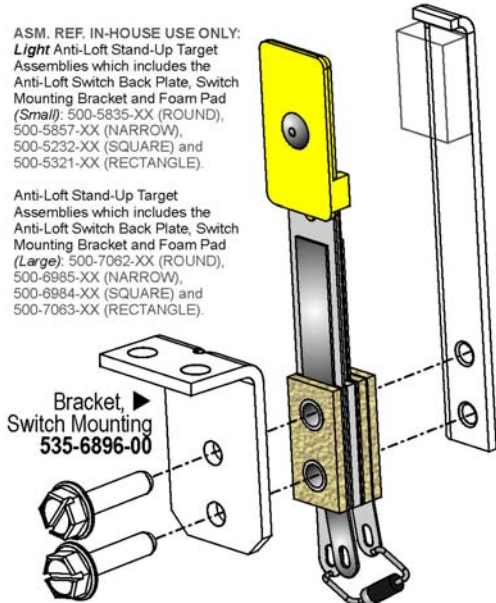

▲ #6-32 X 5/8" Slotted HWH Swage (Zinc) Screws (Qty. 2/per) **237-5976-04**

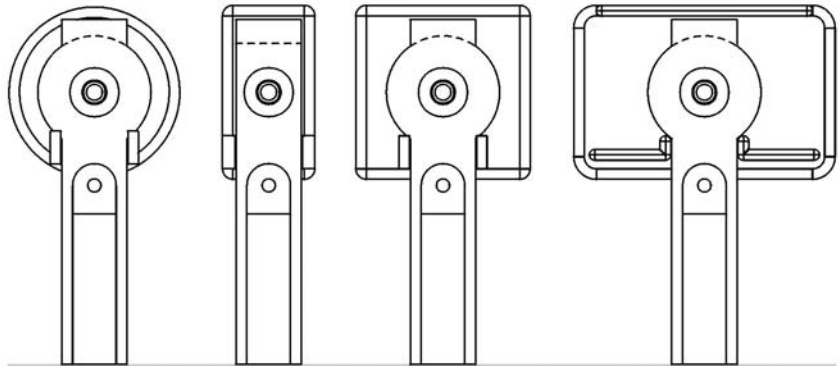

REAR VIEWS OF ANTI-LOFT TARGET & SWITCH ASSEMBLIES

The material of the Anti-Loft Switch has been extended higher to be used with the Anti-Loft Switch Back Plate. **IMPORTANT:** Switch & Target Assemblies (X) without the extension (the predecessors) **SHOULD NOT** be used with an Anti-Loft Switch Back Plate (shown left).

APPENDIX REFERENCE FOR PINBALL GAMES WHICH USED THE BELOW SWITCH & TARGET ASSEMBLIES NOTE:

The Switch & Target Assemblies (X) without the extension have the following part numbers*: 515-5966-XX (Round), 515-5967-XX (Narrow), 515-5162-XX (Square) and 515-6027-XX (Rectangle) and should only be used with the Switch Back Plate (shown right), 535-6452-00 and Small Foam Pad, 626-5029-00.

* If the above referenced part numbers are no longer available from the factory or your distributor, it will be substituted with the appropriate Anti-Loft counterpart. Not all colors may be available.

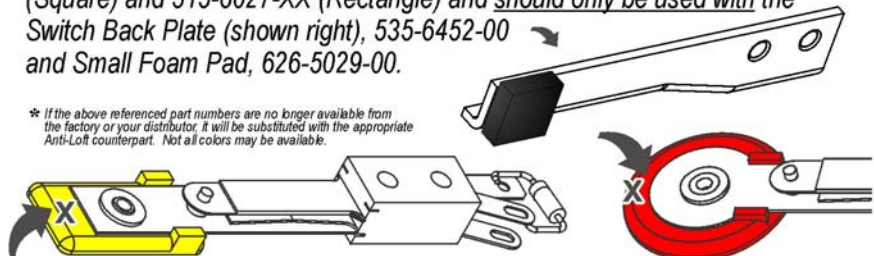

APPENDIX I

Modular Stand-Up Targets

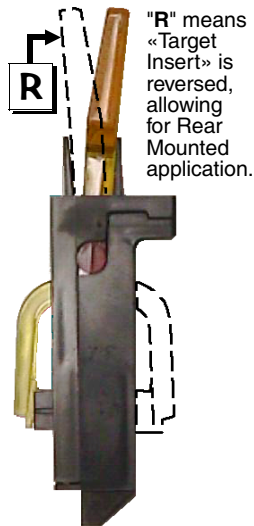

"R" means «Target Insert» is reversed, allowing for Rear Mounted application.



Take Note:

- Items A-E come in various colors. These targets may not be available in every color. The "-XX" in should be replaced with the desired 2-Digit number for the color desired as described in the Color Chart below. As of print date, the following colors were used :
 -01 Clear (A, D); -02 Red (A, B, C, D, E); -03 Amber (D, E);
 -04 Green (A, B); -05 Blue (C); -06 Yellow (A, C),
 -09 Purple (B, D); -11 Fluorescent Green (A, B, D)
- For location(s) and type of Stand-Up Targets used, if any, see Section 4, Chapter 1, Parts Identification & Location.

-XX REPLACE WITH 2-DIGIT FOR COLOR:

- 00 Black
- 01 Clear
- 02 Red
- 03 Amber
- 04 Green
- 05 Blue
- 06 Yellow
- 07 Orange
- 08 White
- 09 Purple
- 10 Fluor. Orange
- 11 Fluor. Green
- 12 Fluor. Blue
- 13 Teal Green
- 14 Gray
- 15 Luminescent
- 16 Gold

Note: Not all colors available.

Nr.	STAND-UP TARGET PARTS	SPI PART Nr.
A	Modular Stand-Up Target Narrow Assy.	500-6138-XX
	Stand-Up Target Narrow (Insert)	545-6138-XX
B	Modular Stand-Up Target Square Assy.	500-6139-XX
	Stand-Up Target Square (Insert)	545-6139-XX
C	Modular Stand-Up Target Rectangle Assy.	500-6228-XX
	Stand-Up Target Rectangle (Insert)	545-6228-XX
D	Modular Stand-Up Target Round Assy.	500-6075-XX
	Stand-Up Target Round (Insert)	545-6075-XX
E	Mod. Stand-Up Target 1" Spherical Assy.	500-6189-XX
	Stand-Up Target 1" Spherical (Insert)	545-6189-XX

To Replace the « Target Insert » or change Target Orientation :

Items A-E Note: For the Target Assembly use the "500-" SPI Part Number(s) shown in the Parts Table below. To receive the Target Assembly with the « Target Insert » « Reversed » simply add a "R" at the end of the Part Number. See Side View picture left to compare (dashed line shows target reversed). For just the «Target Insert» use the "545-" SPI Part Number.

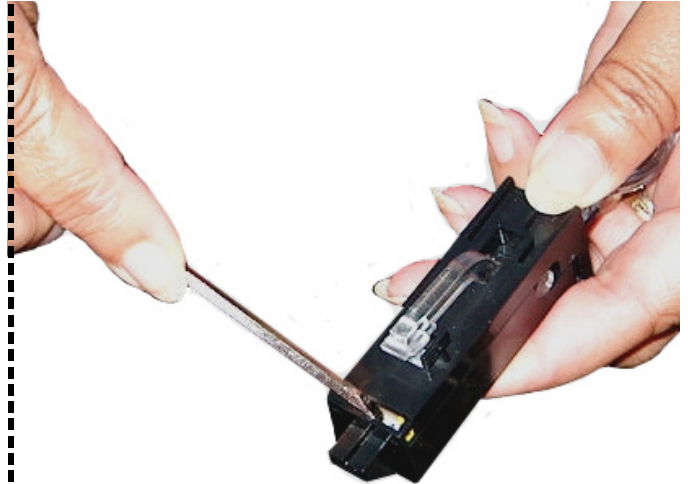

To reverse it yourself or to just change the insert:

- With a small flat head screwdriver, push into the small tab at the bottom of the target front and give a slight twist motion to "pop" the two halves.

- Push the Target Insert bottom in at the same time while you slide the top (front) part up, then let go of the insert as the two halves come apart.

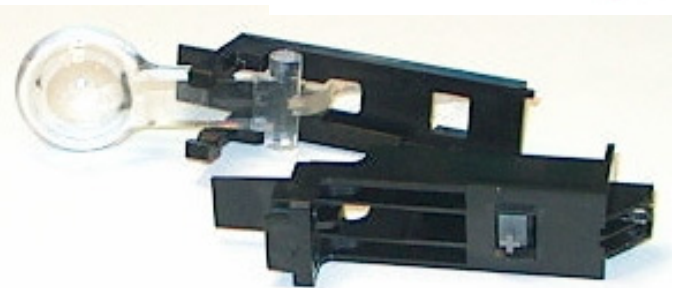

- Replace target or reinsert it into the other size while sliding the two halves back together.

Note: If you were reversing the orientation, don't forget to also turn the Switch Actuator PCB 180°. Test Switch.

APPENDIX J

Coin Cards (USA & International Pricing Defaults) ▶ For Yellow Stock add -Y to the Part Number

If more than one Pricing Scheme is available for countries listed, the **F.** listed beside the option, denotes the Factory Default Setting.
FOR VIEWS OF THE LATEST or OPTIONAL USA, INTERNATIONAL / EURO AND CUSTOM COIN CARDS, VISIT OUR WEBSITE.
 Not Shown USA 755-5400-10 Tournament Option \$2 = X1; 755-5400-11 Tournament Option \$1.50 = X1

USA 10 F. 755-5400-11 Front		USA 10 755-5400-11 Back		USA 2-7 or CANADA 755-5400-02 Front		FOR CUSTOM PRICING † 755-5400-01, -02 or -04 Back		USA 3 with ToPS™ 755-5400-03 or -09 Front		USA 5 with ToPS™ 755-5400-03 Back / -08 Front	
AUSTRALIA 1 F. 755-5406-00 Front		AUSTRALIA 2 755-5406-00 Back		CROATIA 755-5410-00 Front		FOR CUSTOM PRICING † 755-5410-00 Back		DENMARK 1 F. 755-5402-00 Front		DENMARK 2 755-5402-00 Back	
JAPAN 1 755-5408-01 Front		JAPAN 2 F. 755-5408-01 Back		MIDDLE EAST 755-5400-06 Front		ANY COUNTRY CAN USE 755-5400-06 Back		NEW ZEALAND 1 F. 755-5406-00 Back		NEW ZEALAND 2 755-5406-00 Front	
NORWAY 1 F. 755-5403-01 Front		NORWAY 2 755-5403-01 Back		RUSSIA F. 755-5411-00 Front		RUSSIA (ALTERNATE) 755-5411-00 Back		SOUTH AFRICA 755-5409-01 Front		FOR CUSTOM PRICING † 755-5409-01 Back	
SWEDEN 1 F. 755-5404-00 Front		SWEDEN 2 755-5404-00 Back		SWITZERLAND 1 F. 755-5405-00 Front		SWITZERLAND 2 755-5405-00 Back		TAIWAN 755-5412-00 Front		FOR CUSTOM PRICING † 755-5412-00 Back	
UK 1 755-5407-00 Front		UK 3 755-5407-00 Back		UK 5 F. 755-5407-01 Front		FOR CUSTOM PRICING † 755-5407-01 Back		Appendix J Notes: 1. Coin Card on Game is determined by original shipping country destination. 2. Optional Coin Card(s), are available via your distributor or via free download @ www.sterpinball.com/coinagecards.shtml . Older style Coin Cards (foreign or domestic) not available on our website or no longer available through your distributor, are obsolete. 3. Coin Cards which have a Blank Backside can be used for †Custom Pricing.			

Not Shown EURO 755-5401-20 Tournament Custom (can fill in your own pricing).

EURO 1 755-5401-01 1-Side Only		EURO 2 755-5401-02 1-Side Only		EURO 3 755-5401-03 1-Side Only		EURO 4 755-5401-04 1-Side Only		EURO 5 755-5401-05 1-Side Only		EURO 6 755-5401-06 1-Side Only	
EURO 7 755-5401-07 1-Side Only		EURO 8 755-5401-08 1-Side Only		EURO 9 755-5401-09 1-Side Only		EURO 10 755-5401-10 1-Side Only		EURO 11 755-5401-11 1-Side Only		EURO 12 755-5401-12 1-Side Only	

▶ EURO FACTORY DEFAULT SUMMARY TABLE ◀

EURO 1	EURO 2	EURO 3	EURO 4	EURO 5	EURO 6	EURO 7	EURO 8	EURO 9	EURO 10	EURO 11	EURO 12
BELGIUM ITALY 1 PORTUGAL	GERMANY 2	NETHERLANDS SPAIN			GREECE		FINLAND	AUSTRIA	FRANCE		

Section 3, Chapter 4, GO TO ADJUSTMENTS MENU, Adj. 18, Game Pricing, USA & International (non-Euro) and Euro 1-12 Summary & International (Euro) Standard Pricing Select Tables, summarizes Standard or Custom Pricing Schemes & the Dip Switch Setting required.





In SWITCH MENU also select:

ACTIVE and DEDICATED SWITCH TESTS

SWITCH MATRIX GRID & DEDICATED SWITCHES (for notes & locations, see Page DR. 4 or 17)

Column (Drive)	1: Q1	2: Q2	3: Q3	4: Q4	5: Q5	6: Q6	7: Q7	8: Q8	GROUND	GROUND
Row (Return)	GRN-BRN CN5-P1	GRN-RED CN5-P3	GRN-ORG CN5-P4	GRN-YEL CN5-P5	GRN-BLK CN5-P6	GRN-BLU CN5-P7	GRN-VIO CN5-P8	GRN-GRY CN5-P9	IC U206 INPUTS	BLK CN6-P1, -P11
1: U400	1 Cabinet Side WHT-BRN CN7-P9 LEFT BUTTON (UK ONLY) Sw. Part Number: 180-5160-00	9 Below P/F COMIC BOOK GUY STANDUP 515-6027-08	17 Below P/F DROPTARGET #1 (TOP) 180-5158-00	25 Abv. Upr. P/F UPPER PLAYFIELD EXIT 180-5190-28	33 Blw. Upr. P/F UPF LIGHT STANDUP 515-5966-04	41 Below P/F BULLY 3-BANK (TOP) 515-6027-08	49 Below P/F LEFT BUMPER 180-5015-03	57 Below P/F LEFT OUTLANE 500-6227-02	1: U206 GRY-BRN CN6-P2	DS-1 on Cabinet Side #1 LEFT FLIPPER BUTTON 180-5160-00
2: U400	2 Coin Door WHT-RED CN7-P8 4TH COIN SLOT 180-5204-00	10 Below P/F 5-BALL TROUGH #1 (LEFT) 180-5119-02	18 Below P/F DROPTARGET #2 (MID) 180-5158-00	26 Blw. Upr. P/F GARAGE RAMP ENTER 180-5190-28	34 Blw. Upr. P/F UPF LOCK STANDUP 515-5966-04	42 Below P/F BULLY 3-BANK (MID) 515-6027-08	50 Below P/F RIGHT BUMPER 180-5015-03	58 Below P/F LEFT RETURN LANE 500-6227-02	2: U206 GRY-RED CN6-P3	DS-2 Below Playfield #2 LEFT FLIPPER E.O.S (End-of-Stroke) 180-5149-00 on Flipper
3: U400	3 Coin Door WHT-ORG CN7-P7 6TH COIN SLOT Future Use	11 Below P/F 5-BALL TROUGH #2 180-5119-02	19 Below P/F DROPTARGET #3 (BOT) 180-5158-00	27 NOT USED	35 Blw. Upr. P/F UPF TOP STANDUP 515-5966-02	43 Below P/F BULLY 3-BANK (BOT) 515-6027-08	51 Below P/F BOTTOM BUMPER 180-5015-03	59 Below P/F LEFT SLINGSHOT 180-5054-00 (x2)	3: U206 GRY-ORG CN6-P4	DS-3 on Cabinet Side #3 RIGHT FLIPPER BUTTON 180-5164-00 Doubled
4: U400	4 Coin Door WHT-YEL CN7-P6 RIGHT COIN SLOT 180-5204-00	12 Below P/F 5-BALL TROUGH #3 180-5119-02	20 Below P/F ITCHY & SCRATCHY SAUCER 180-5116-01	28 NOT USED	36 Abv. Upr. P/F COUCH ENTER 180-5190-28	44 Above P/F UP RIGHT SAUCER BACKUP 180-5119-02	52 Below P/F POP SIDE STANDUP 515-6027-08	60 Below P/F RIGHT OUTLANE 500-6227-02	4: U206 GRY-YEL CN6-P6	DS-4 Below Playfield #4 RIGHT FLIPPER E.O.S. (End-of-Stroke) 180-5149-00 on Flipper
5: U401	5 Coin Door WHT-GRN CN7-P5 CENTER COIN SLOT / DBA 180-5204-00	13 Below P/F 5-BALL TROUGH #4 180-5119-02	21 Above P/F SPINNER 180-5010-04	29 Below P/F KWIK-E-MART LOOP 500-6227-02	37 Blw. Upr. P/F TV LOCKUP 500-6227-02	45 Above P/F RIGHT RAMP ENTER 180-5190-28	53 In Cabinet TOURNAMENT BUTTON 180-5174-00	61 Below P/F RIGHT RETURN LANE 500-6227-02	5: U206 GRY-GRN CN6-P7	DS-5 on Cabinet Side #5 UPPER RT. FLIPPER BUTTON 180-5164-00 Doubled
6: U401	6 Coin Door WHT-BLU CN7-P3 LEFT COIN SLOT 180-5204-00	14 Below P/F 5-BALL TROUGH VUK OPTO See Sw. 14 Note	22 Below P/F BART SKATEBOARD TOP 180-5190-48	30 Below P/F KWIK-E-MART STANDUP 515-6027-08	38 Abv. Upr. P/F COUCH LOCK (BOT) 180-5119-02	46 Above P/F RIGHT RAMP MADE 180-5190-28	54 In Cabinet START BUTTON 180-5174-00	62 Below P/F RIGHT SLINGSHOT 180-5054-00 (x2)	6: U206 GRY-BLU CN6-P8	DS-6 on Coin Door #6 VOLUME (RED BUTTON) (In Test: LEFT) 180-5192-02
7: U401	7 Coin Door WHT-VIO CN7-P2 5TH COIN SLOT Future Use	15 Below P/F 5-BALL STACKING OPTO See Sw. 15 Note	23 Below P/F BART SKATEBOARD 180-5190-48	31 Below P/F ADV. POPS STANDUP 515-5966-07	39 Abv. Upr. P/F COUCH LOCK (MID) 180-5119-02	47 Above P/F LEFT RAMP ENTER 180-5190-28	55 Below P/F UPPER LEFT VUK 180-5116-01	63 Below P/F LEFT ORBIT 500-6227-02	7: U206 GRY-VIO CN6-P9	DS-7 on Coin Door #7 SERV. CRED. (GREEN BUTTON) (In Test: RIGHT) 180-5192-04
8: U401	8 Cabinet Side WHT-GRY CN7-P1 RIGHT BUTTON (UK ONLY) 180-5160-00	16 Below P/F SHOOTER LANE 180-5157-00	24 Below P/F UPPER RIGHT SAUCER 180-5186-00	32 Below P/F LIGHT OTTO STANDUP 515-5966-08	40 Abv. Upr. P/F COUCH LOCK (TOP) 180-5119-02	48 Below P/F GARAGE DOOR 500-6138-01R	56 In Cabinet PLUMB BOB TILT See Sw. 56 Note	64 Below P/F RIGHT ORBIT 500-6227-02	8: U206 GRY-BLK CN6-P10	DS-8 on Coin Door #8 BEGIN TEST (BLACK BUTTON) (In Test: ENTER) 180-5192-00



In LAMP MENU also select:

TEST ALL LAMPS, ROW & COLUMN LAMP TESTS

LAMP MATRIX GRID (for notes & locations, see Page DR. 5 or 23)

Column (18v)	1: U17	2: U16	3: U15	4: U14	5: U13	6: U12	7: U11	8: U10
Row (Ground)	YEL-BRN J13-P9	YEL-RED J13-P8	YEL-ORG J13-P7	YEL-BLK J13-P6	YEL-GRN J13-P5	YEL-BLU J13-P4	YEL-VIO J13-P3	YEL-GRY J13-P1
1: Q33	1 #555 Bulb RED-BRN J12-P1 LEFT OUT EXTRA BALL	2 #555 Bulb LEFT RETURN EXTRA BALL	3 #555 Bulb SHOOT AGAIN	4 #555 Bulb RIGHT RETURN EXTRA BALL	5 #555 Bulb SPECIAL	6 #555 Bulb SHOOTER LANE SKILL SHOT	7 #555 Bulb LIGHT OTTO	8 #555 Bulb ADV. POPS
2: Q34	9 #555 Bulb RED-BLK J12-P2 SPAY ANYTHING	10 #555 Bulb KITTY KITTY BANG BANG	11 #555 Bulb FIELD OF SCREAMS	12 #555 Bulb ESOPHAGUS NOW	13 #555 Bulb I&S ARROW	14 #555 Bulb START I&S MULTIBALL	15 #555 Bulb I&S 2X SCORING	16 #44 Bulb (x2) POPS 2X SCORING
3: Q35	17 #555 Bulb RED-ORG J12-P3 LEFT POP BUMPER	18 #555 Bulb RIGHT POP BUMPER	19 #555 Bulb BOTTOM POP BUMPER	20 #555 Bulb MORE TIME	21 #555 Bulb COLLECT NUCLEAR PLANT	22 #555 Bulb LEFT ORBIT ARROW	23 #555 Bulb CLETUS 2X SCORING	24 #555 Bulb LEFT ORBIT HURRY UP
4: Q36	25 #555 Bulb RED-YEL J12-P4 CBG SKILL SHOT	26 #555 Bulb CGB START HURRY UP	27 #555 Bulb DAREDEVIL RAMPS	28 #555 Bulb DAREDEVIL BUMPERS	29 #555 Bulb DAREDEVIL LOOPS	30 #555 Bulb DAREDEVIL TARGETS	31 #555 Bulb START BUTTON	TOURNAMENT BUTTON
5: Q37	33 #555 Bulb RED-GRN J12-P5 LEFT RAMP ARROW	34 #555 Bulb TREEHOUSE OF HORROR	35 #555 Bulb TREEHOUSE 2X SCORING	36 #555 Bulb LEFT RAMP HURRY UP	37 #555 Bulb RIGHT RAMP ARROW	38 #555 Bulb GET DUFFED!	39 #555 Bulb MOE'S 2X SCORING	40 #555 Bulb RIGHT RAMP HURRY UP
6: Q38	41 #555 Bulb RED-BLU J12-P6 MINI LOOP ARROW	42 #555 Bulb 2X SCORING KWIK-E-MART	43 #555 Bulb KWIK-E-MART HURRY UP	44 #555 Bulb GARAGE ARROW	45 #555 Bulb CLEAN THE GARAGE	46 #555 Bulb GARAGE 2X SCORING	47 #555 Bulb GARAGE HURRY UP	48 #555 Bulb RIGHT ORBIT ARROW
7: Q39	49 #555 Bulb RED-VIO J12-P8 RIGHT LOOP ARROW	50 #555 Bulb OTTO'S BUS TOURS	51 #555 Bulb ELEMENTARY 2X SCORING	52 #555 Bulb BULLY 3-BANK (TOP)	53 #555 Bulb BULLY 3-BANK (MID)	54 #555 Bulb BULLY 3-BANK (BOT)	55 #555 Bulb KRUSTY 2X SCORING	56 #555 Bulb RIGHT ORBIT HURRY UP
8: Q40	57 #555 Bulb RED-GRY J12-P9 HOMER	58 #555 Bulb MARGE	59 #555 Bulb BART	60 #555 Bulb LISA	61 #555 Bulb MAGGIE	62 #555 Bulb GRANDPA	63 #44 Bulb LEFT HEADLIGHT	64 #44 Bulb RIGHT HEADLIGHT
9: Q41	65 #555 Bulb RED-WHT J12-P10 LIVING ROOM 2X SCORING	66 #555 Bulb (LIGHT) LOCK	67 #555 Bulb LIGHT (LOCK)	68 #555 Bulb LOCK (SQUARE)	69 #555 Bulb SUPER JACKPOT	70 #555 Bulb TV ARROW	NOT USED	NOT USED
10: Q42	73 Green LED RED J12-P11 (LED) DUFFMAN	74 Green LED (LED) HOMER'S DAY	75 Green LED (LED) WILLIE'S WOES	76 Green LED (LED) WIGGUM VS SNAKE	77 Green LED (LED) BART'S DAY	78 Green LED (LED) KRUSTY'S LAST STAND	79 Green LED (LED) STOP THE MONORAIL	80 Red LED (x2) (LED) ALIEN INVASION

▼ U.S. ▼
Customary
Inch Ruler

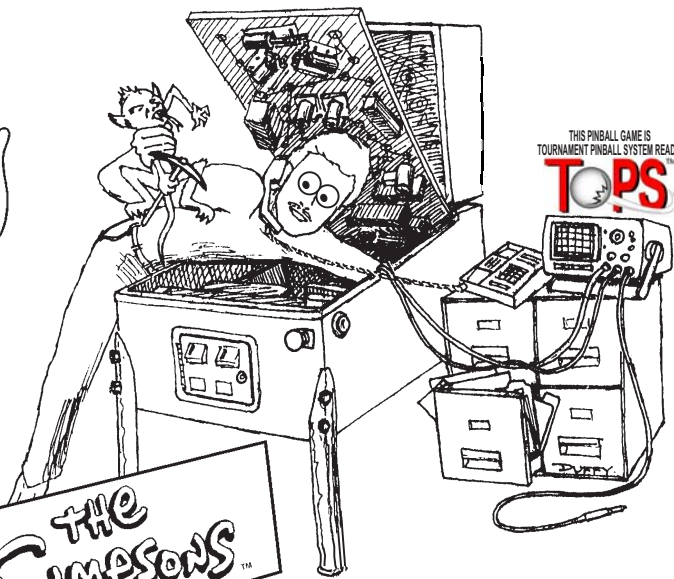

THE SIMPSONS™

PINBALL PARTY

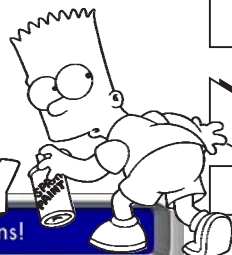

Metric Conversion

$1" = 2.54\text{cm} / 25.4\text{mm}$
 $1\text{cm} = .3937"$
 $1\text{mm} = .03937"$

- For metric, multiply inch value by metric value, e.g. 5" X 2.54cm = 12.7cm or 127mm.
- For US, multiply metric value by inch value, e.g. 13cm X .3937" = 5.1181"



<http://www.SternPinball.com>

Visit our website for Pinball game information, Technical Support & Part Sales (for Service Bulletins and a whole lot more!), Stern News, Pinball Links and Distributor Listings. **HELP US, HELP YOU!** If you have any suggestions, questions, need technical advice, find errors or have comments, contact us through our website or call!

This Game Service Manual and all other documents relating to this product, playfield components, features, rules, programming and operation are subject to change without notice (Service Bulletins, if applicable, available through our website).



2020 Janice Avenue, Melrose Park, IL 60160

7
7
3
5
2
4
5
4
0
0
8
7
1

Tel 708-345-7700 (Option 1) Fax 708-345-7889 eMail parts.service@SternPinball.com



7 8 0 - 5 0 7 7 - 0 1