



888-538-1000  
 TEL (561) 588-5200  
 FAX (561) 493-2999  
 PARTS FAX (561) 493-2990  
 PARTS: (561)253-3311 SERVICE: (561)253-3310

51 Hypoluxo Rd  
 Hypoluxo, FL 33462-4501  
[www.benchmarkgames.com](http://www.benchmarkgames.com)

POP IT & WIN



PLEASE READ FIRST BEFORE  
 PLUGGING IN MACHINE

ALL RIGHTS RESERVED. PAT. PENDING

140-MAN-001



## Contents

REVISION HISTORY .....	2
BASIC COMPONENTS .....	3
GAME PLAY/SEQUENCE BEHAVIOR .....	4
GAME SETUP .....	6
MAIN ELECTRONIC COMPONENTS .....	10
TECHNICAL OPERATION .....	18
PROGRAMMING OPTIONS .....	28
ALTERNATIVE COIN AND CARD-SWIPE SYSTEM CONFIGURATIONS .....	33
ERROR CODES AND TROUBLESHOOTING GUIDE .....	35
AIRPUMP ASSEMBLY DIAGRAMS .....	40

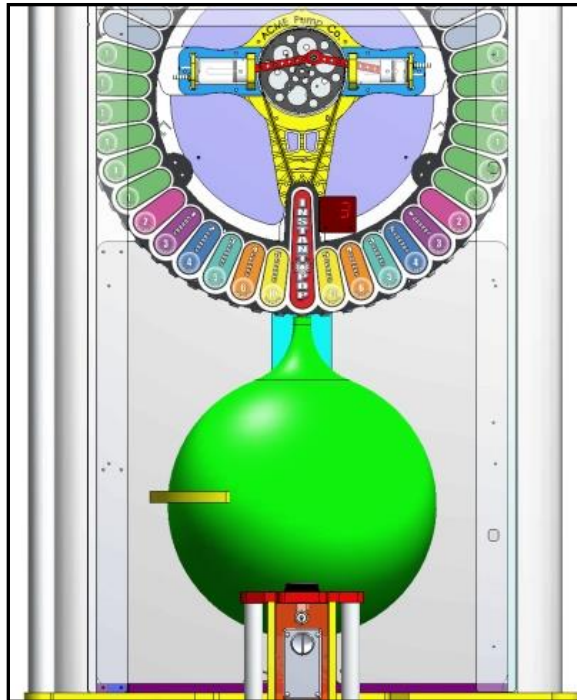

## REVISION HISTORY

-04/09/14: REV-A: Created.

-04/28/15: REV-B: Error Codes Corrected

-06/02/15: REV-C: Mini High Current Board information Added

-01/18/16: REV-D: Payout table default correction

-12/01/16: REV-E: Visual aid changes on pgs. 5, 7, 28, 29, 41. Fuse Information change on pg. 7. Added part numbers to pg. 31

Benchmark Games Inc. holds exclusive copyright in the Hardware and Software contained within this game machine. Benchmark also owns the copyright in the ARTWORK DESIGNS, MUSIC, and original SOUND EFFECTS that are incorporated in the game machine. No part of this artwork, music, sound effects, images, displays, software or firmware may be reproduced in any way without the express written permission of Benchmark Games Inc. Benchmark Games Inc. also retains other various intellectual property rights in the game machine including pending patent rights, trade press rights and trademarks.

PERSONS WISHING TO MAKE USE OF ANY OF THE INTELLECTUAL PROPERTY DESCRIBED ABOVE SHOULD CONTACT BENCHMARK GAMES INC. IN THE FIRST INSTANCE.

Every effort has been made to ensure that the information contained within this manual is accurate. Benchmark Games Inc. reserves the right to make alterations without prior notice.

## BASIC COMPONENTS



Pop-it & Win! is a game configuration in which players attempt to stop a running light pattern in certain target positions, in order to obtain air inflation time to pop a balloon. Additionally, with a large digital display located above the game, players are motivated to win the Jackpot, therefore increasing the potential revenue of the machine.

## GAME PLAY/SEQUENCE BEHAVIOR

### ***I-Power-up initialization Sequence (10 seconds):***

All devices demonstrate they are operational:

- Initialization sound comes up
- Column lights flash
- Air-pump and light-strips run for two seconds
- Saw motor and light-strips run for two seconds
- Playfield lights show a pattern
- Player Credit Display show pattern
- Marquee Jackpot Display shows pattern
- Marquee Lights show pattern
- The game will setup and inflate a new balloon if necessary
- The game will then go into Attraction-mode, or Play-mode, if there were any previous credits saved.

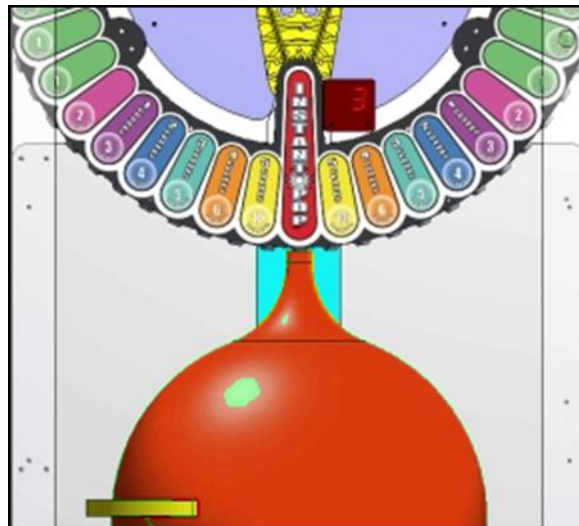

### ***II- Attraction Mode:***

- Various light patterns are shown while some background sound plays on.
- Note that, there is a low-activity rest period (which is programmable, see section) before this sequence is re-triggered, to avoid being too repetitive.

### ***III- Adding Money (Coin-Mech. / Card-swipe system):***

- "Coin-in" sound is heard on corresponding speaker.
- When enough money is added to buy credit(s), the current credits value will be shown on the two-digit display, and the game will enter Play-Mode.

#### **IV- Play Mode:**

- Play-mode start sound “Lightning Bolt” is heard.
- The Playfield Lights will start the clockwise spinning pattern fading in behind a quick ‘glow down’ pattern.

#### **V- Player Hits Button:**

- Light ‘puck’ stops immediately and flashes in its current position.
- Credit will be decreased.
- Air pump runs to inflate balloon proportionally by a preset amount (operator programmable depending on the target hit within the playfield).
- If player has more credits, the light spinning will restart for a new try, otherwise the game will exit and go back into Attract-Mode.

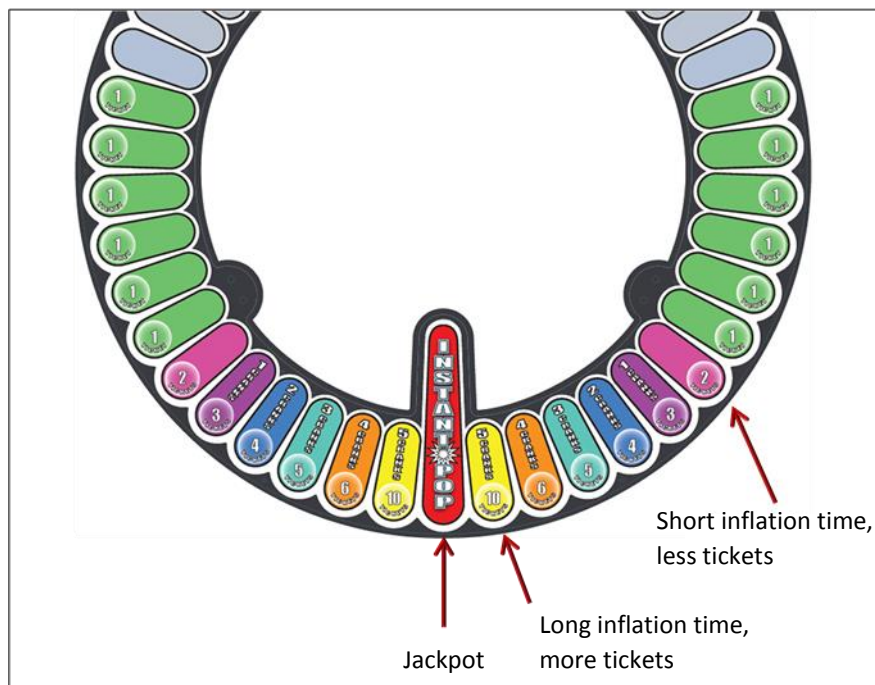

#### **VI- Game Win, normal (Balloon pops against saw blade after progressive inflation)**

- Playfield and lights will flash and sound effects will begin, lasting about 10 seconds.
- The Jackpot value display will show a quick ‘countdown’ pattern to simulate an award value ‘download’. It then resets to the initial minimum-jackpot value.
- The Jackpot value tickets won start being paid on the ticket dispensers, and the corresponding player’s credit display will show a slow countdown as the tickets come out.
- Simultaneously, the balloon load mechanism will initiate a sequence to put a new balloon in place for the next game.  
Note: The mechanism assumes balloons are used sequentially, and will try up to three positions to find a spot with an actual balloon.

- If player has more credits, the machine will continue on play mode, otherwise the game will go back into Attract-Mode.

## VII- Game Win, Jackpot Hit

- Light 'puck' stops immediately and flashes in its current position. All other lights turn off for 2 seconds.
- All lights commence flashing and sound effects will begin, lasting at least 20 seconds.
- Air pump will start inflating the balloon all the way until it pops against the rotating saw blade. Tickets will then be awarded as in section VI above.
- Simultaneously, the balloon load mechanism will initiate a sequence to put a new balloon in place for the next game.  
Note: the mechanism assumes balloons are used sequentially, and will try up to three positions to find a spot with an actual balloon.  
If the player has more credits, the machine will continue on play mode, otherwise the game will go back into Attract-Mode.

## GAME SETUP

### Unloading/Assembly

The game is pre-assembled in the factory; all you have to do is unpack it and check/locate the following:

- The cabinet keys are tie-wrapped to the lower chute door handle.
- Remove any shipping foam that might still be holding any parts.
- Pop-it & Win breaks down into two main components: the game and the marquee.
  - o Caution when unloading the Marquee from the game when first received.
  - o The bolts used to attach the Marquee to the game are Zip-tied to the back to the marquee for shipping purposes.
  - o The Marquee is attached by two Hex head-Cap screws ( $\frac{1}{4}$ -20 x 1.5"L) that are placed in the two spots shown in both ① and ②. Connect the harness from the marquee (126HNS018) to the game harness (129HNS004) to finish assembly.

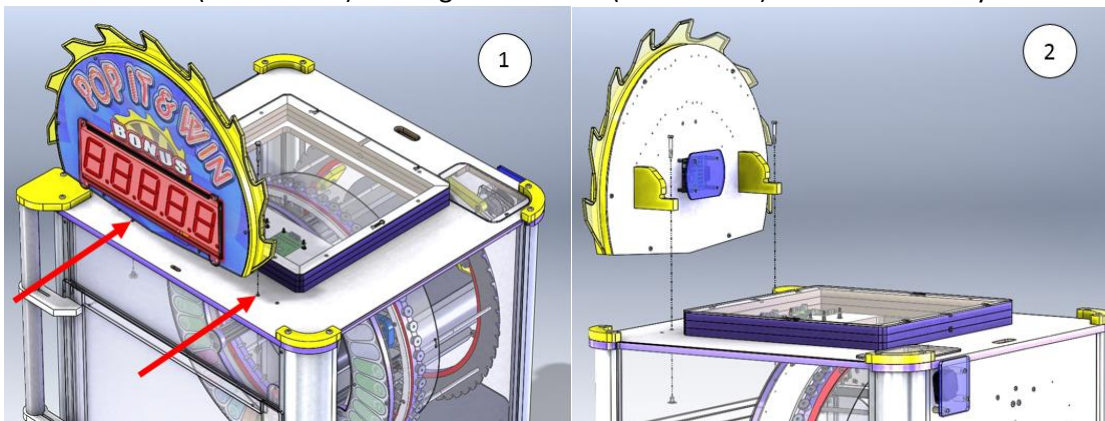

## Power up

- The power cord is stored inside the cash drawer, along with this manual and any spare parts included.

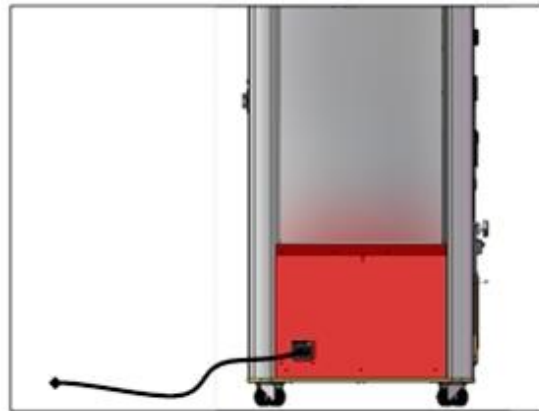

- Plug-in the machine and turn it on from the Switch located on the lower-left side of the cabinet.

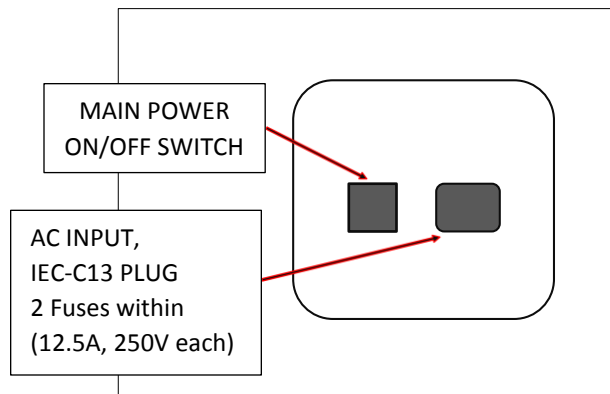

Note: There are two AC fuses within the power supply's IEC-320 receptacle (10Amp, 250V each).

## First-Time Setup

- Ensure that all motors/sensors work by observing the sequence described on section 2-I.
- Any major anomaly, if present, should be seen at this point.
- If a Balloon is not already in place, let the automatic indexer load the next one, or place one by hand.
- Run through the 'Programming Mode' options and define your desired settings, like credits settings, sound volumes, etc. (See Section 'Programming Options' for Benchmark's defaults).
- Confirm your settings to ensure they are what you wanted.

## ***Recommended Balloon Stock***

The type and quality of the balloons used in the game will correlate directly to reliability and revenue. Be sure to use the correct size and quality balloons.

We recommend our 16" latex colored balloons. Please contact our sales or parts department to order those.

## ***Recommended Payout Settings***

Note: Tweaking the payout of the machine to low levels will affect your net revenue negatively. Fair payout (28-35%) should maximize net income. The player recognizes an investment in the price they have paid for the balloon to inflate, and will be more apt to insert more money if the balloon shows generous progress on the way to an inevitable win.

-Section "Programming Options" of this manual describes the different Settings that can be used to configure the machine. From those settings, the following are the ones that will most likely affect the payout-percentage and the income of the machine:

- Coins-per-credit
- Plays-per-credit.
- Inflation proportion
- Jackpot Win Window Tolerance.
- Payout Table
- Jackpot Minimum
- Jackpot Increment

The currently selected payout table determines the amount of tickets awarded for the different targets hit by the players.

Note that the different payout-tables require corresponding artwork to be installed over the playfield lights. All payout-tables are shown in "Programming Options".

A few example setups to get started with are the following,

Note that other combinations are possible, depending on your particular audience:

### **Table A:**

-Plays per Credit:	1
-Jackpot Increment:	1
-Minimum Jackpot:	320
-Maximum Jackpot:	1000
-Jackpot Window:	4
-Air Inflation:	3
-Payout Table:	"A"

### **Table B:**

-Plays per Credit:	2
-Jackpot Increment:	3
-Minimum Jackpot:	600
-Maximum Jackpot:	1000

-Jackpot Window: 4  
-Air Inflation: 3  
-Payout Table: "B"

**Table C:**

-Plays per Credit: 3  
-Jackpot Increment: 1  
-Minimum Jackpot: 320  
-Maximum Jackpot: 1000  
-Jackpot Window: 4  
-Air Inflation: 3  
-Payout Table: "C"

**Table E:**

-Plays per Credit: 1  
-Jackpot Increment: 1  
-Minimum Jackpot: 100  
-Maximum Jackpot: 1000  
-Jackpot Window: 4  
-Air Inflation: 2  
-Payout Table: "E"

We recommend that you start with the default settings. If you want to increase or decrease the cost per credit, you should adjust the 'Payout Table', 'Jackpot Minimum' and the 'Jackpot Increment' options appropriately.

For example, if you start at \$0.50 per play and you want to go to \$1.00 per play, you should change the 'Payout Table' from B to C, the 'Jackpot Minimum' from 320 to 640, and the 'Jackpot Increment' from 1 to 2. If you want to further tweak the payout you can adjust the 'Inflation Proportion' setting to increase or decrease the amount of air per pump cycle. The 'Jackpot Win Window' to adjust the difficulty of hitting the Jackpot, the 'Jackpot Minimum' to increase or decrease the average jackpot value, and the 'Jackpot Increment' to increase or decrease the average Jackpot value.

**Other Considerations:** Any of the settings that are adjusted may have a dramatic effect on how much revenue the machine makes. Players like to see the balloon inflate and like the opportunity to win a substantial Jackpot. Reducing these will probably reduce play and revenue.

A payout estimator for this game is located under 'CUSTOMER SUPPORT' at the [benchmarkgames.com](http://benchmarkgames.com) website. This calculator allows you to plug in different configuration values and get an idea of the expected payout %.

# MAIN ELECTRONIC COMPONENTS

PCB BOARD LOCATIONS, MAIN CONTROL PANEL:

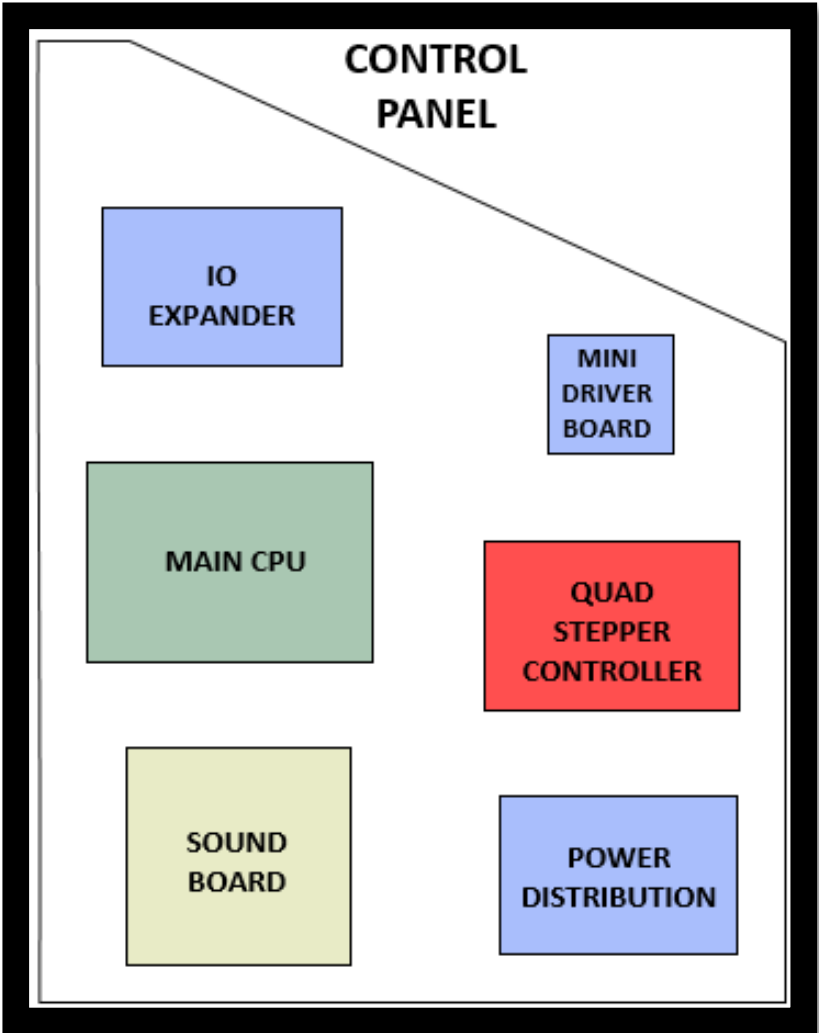

## Power Distribution Board

Part# PCB00032

Qty: 1

Location: Back Panel.

ID-Switch setting: None, board has no computer.

Distributes DC power from the power-supply to the different devices, through a Poly-Switch (thermal, resettable fuse) for each voltage circuit. Note that for convenience, the 'Programming Options' Buttons are also located on this board, even though they're not power-related.

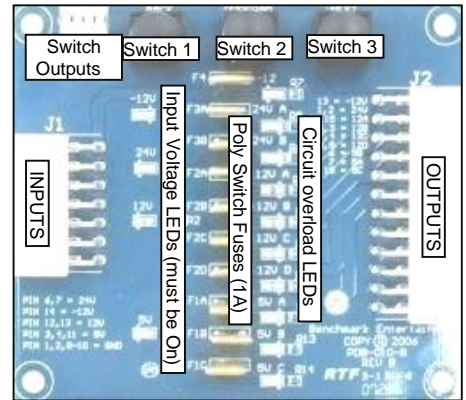

Power is distributed in the following manner (worst case estimations):

### BOARD/DEVICE

<b><u>POWER DISTRIBUTION BOARD</u></b>		
<b><u>CIRCUITS</u></b>		
INPUTS	Value MIN	Value MAX
5V	360mA	431mA
12V	1.1A	2.48A
24V	916mA	2.422A
OUTPUTS		
5V-A	388mA	402mA
5V-B	34mA	77mA
12V-A	105mA	111mA
12V-B	790mA	1.509A
12V-C	0A	0A
12V-D	201mA	2.4A
24V-A	400mA	1.519mA
24V-B	261mA	265mA
DEDICATED 'PIGTAIL' TERMINALS:		
Column Lights	12V pigtail	1.8A (7Amp Fuse)
Air-Pump Motor Driver	24V pigtail	2.8A (10 Amp Fuse)

Related Note: There are 2 AC fuses on the Power supply IEC-130 receptacle (10Amp, 250 V).

## **Main CPU Board (BMC-001-B)**

Part# 140PCB001

Qty: 1

Location: Control Panel.

ID-Switch setting: None Master board needs no ID.

This board is the main controller of the game. It decides all the game actions and commands the other boards to act according to the game scheme.

Communication to the other boards is performed via a 485 differential wire-pair (Gray and blue wires).

The 'Programming Mode' game-settings information is saved in an on-board FRAM chip.



### **Main ROM program Version Updates:**

(None)

## **IO-Expander Board**

This board can handle 16 inputs and outputs as commanded remotely by the Main CPU board through the 485 serial pair.

TYPES:

-Part# 500PCB022

Qty: 5

### **- CONTROL PANEL, 1 board**

Controls column light strips for the cabinet.

Receives the balloon sensors detection signal, and conveys it to the main-CPU board when prompted.

Receives the programming-button signals coming from the Power Dist.

Board

Firmware: **IO-exp Generic 2.3 or above**

ID-Switch setting: **0000 (off, off, off, off)**

### **- MARQUEE, 1 Board**

This controls the lights on the overhead marquee, respectively.

Firmware: **IO-exp Generic 2.3 or above**

ID-Switch settings: **1100 (on, on, off, off)**

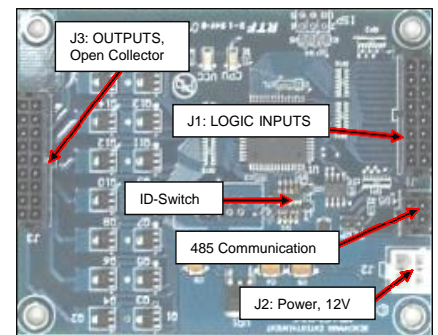

-Part# 129PCB005

Qty: 3

- CABINET TOP

These control the 42 game playfield lights, as illustrated below. Only the first board for each playfield has 485 communication with the Main CPU board. The second and third boards of each playfield have an ID that is only relevant within the playfield group (they are slaves to the first one in the group, controlled by a custom 5-wire communication bus)

Firmware: **Explosive-Playfield 1.1**  
ID-Switch settings: **1000 (on, off, off, off), 1100 (on, on, off, off), 0010 (off, off, on, off)**

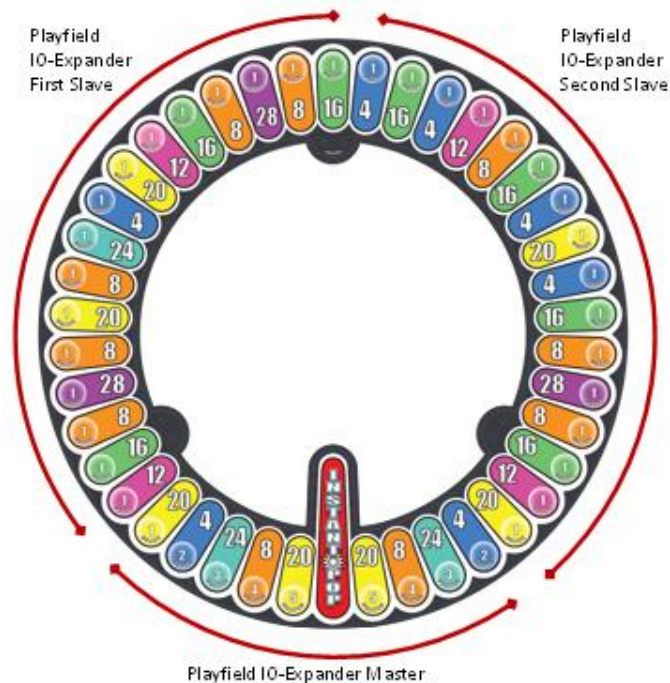
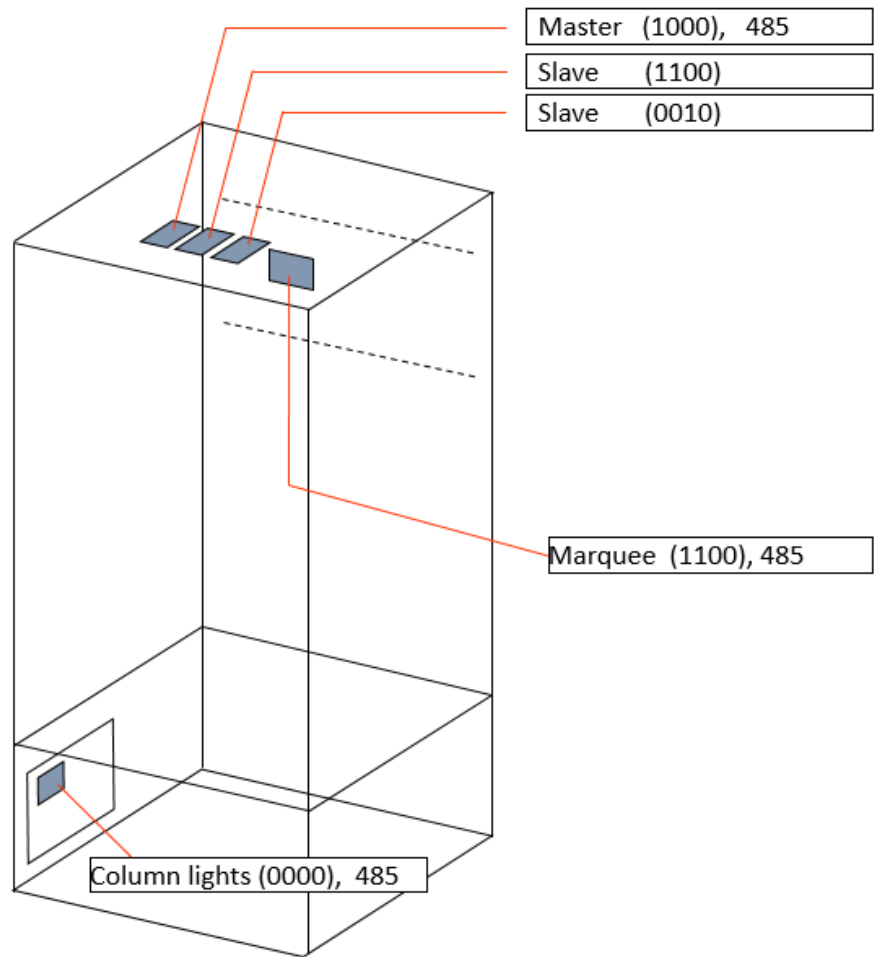

### Quad Stepper Board

Part# PCB00068

Qty: 1

Location: Control Panel

ID-Switch setting: **00 (off, off)**

This Stepper-motor controller board handles the movements of the 'saw-blades' and the balloon indexer wheels.

Motor control output goes in groups of 4 wires off the J1 connector:

Saw: Motor 1

Balloon Indexer: Motor 2

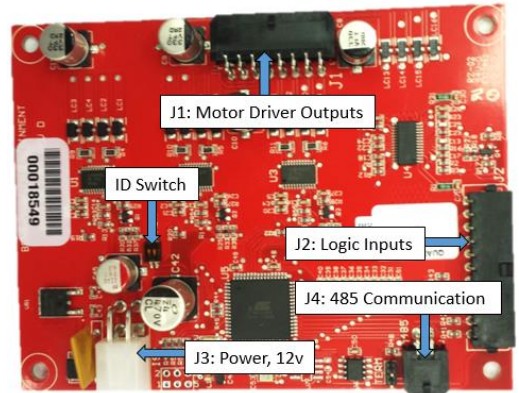

### Sound Board

Part# 129PCB003

Qty: 1

Location: Control Panel

ID-Switch setting: **0000 (off, off, off, off)**

Handles background and event sounds.

Sound files are stored on the plug-in SD-card memory board.

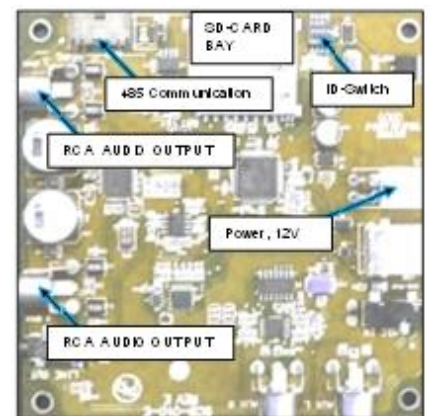

### Mini High Current Board (Mini Driver Board)

Part# PCB00017

Qty: 1

Location: Control Panel

ID-Switch settings: None, it has no 485 connection

It drives the solenoids for the blow up valve.

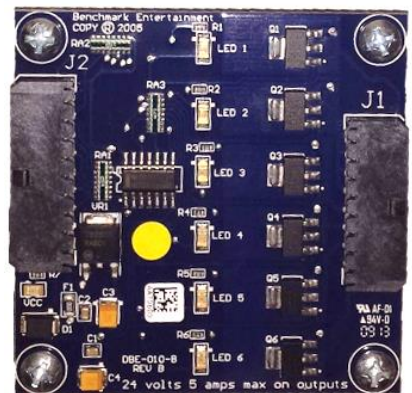

### Small 4-Digit Display (player credits)

Part# PCB00067 [485 capable, connector in front]

Qty: 1

Location: Front of Playfield

ID-Switch settings: **0000 (off, off, off, off)**



**Large 5-Digit Jackpot Display  
(Overhead Marquee)**

Part# PCB00015

Qty: 1

Location: Marquee

ID-Switch setting: **0100 (off, on, off, off)**



**DC Motor Driver Board (Air pump)**

Part# PCB00064

Qty: 1

Location: Behind Air-pump panel

ID-Switch setting: None, board has no computer

Handles Air-pump motor.

Receives digital PWM signal from main CPU board.

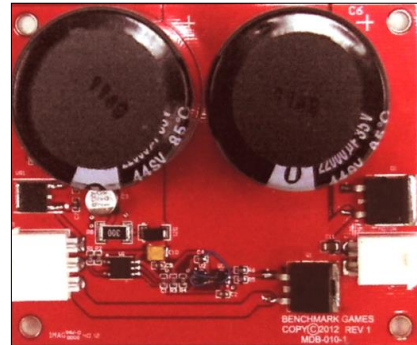

**24V DC Motor (Air- pump)**

Part# 500ASM119

Qty: 1

Location: Behind Air pump assembly



## 24V DC Stepper Motor

Part#:

- 500ASM103 (Balloon Indexer)
- 500ASM108(Saw Blade)

Qty: 2

Location: Upper/right of cabinet for balloon indexer, and behind saw blade.



## Balloon Indexer Switch

Part# ELM00165

Qty: 1

Location: Top Right of the cabinet, behind balloon indexer, within Indexer motor assembly.

Detects position of Balloon indexer cam.

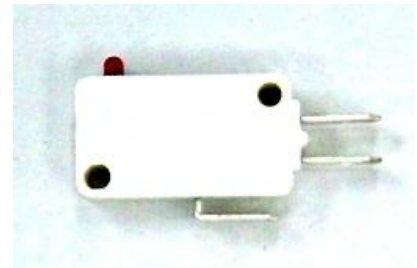

## Balloon Sensor

Part#ELM00188

Parallax PING Ultrasonic sensor

Qty: 1

Location: Behind Saw-Blade Extrusion

Detects balloon size by echo-time measurement.  
No calibration necessary.



## Air Valve Solenoid

Part# 500ASM124

Qty: 1

Location: Lower part of playfield, under air-pump assembly.



**Coin Mech. (factory default)**

Part# ELM00301  
MPU WJ-A17, 12V DC, 20-28.5mm coin  
Qty: 1  
Location: Front Door



**Hard-meter Pair (optional only)**

Part# 500ASM020 [2-in-1 Assembly, with common connector]  
Qty: x2 meters  
Location: Cash Drawer  
Non-resettable type  
#1 (left): Coin-in Count  
#2(Right): Ticket

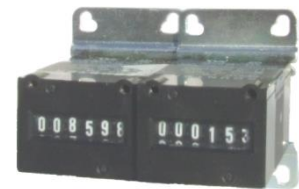

**Ticket Dispensers (Intelli-Triple Series)**

Part# 112ASM001  
Qty: 1  
Location: Ticket Drawers

On this game, the ticket dispensers use the standard 'Run' and 'Notch' signals common in the redemption industry.  
For more information, see Benchmark's Ticket Dispenser manual.

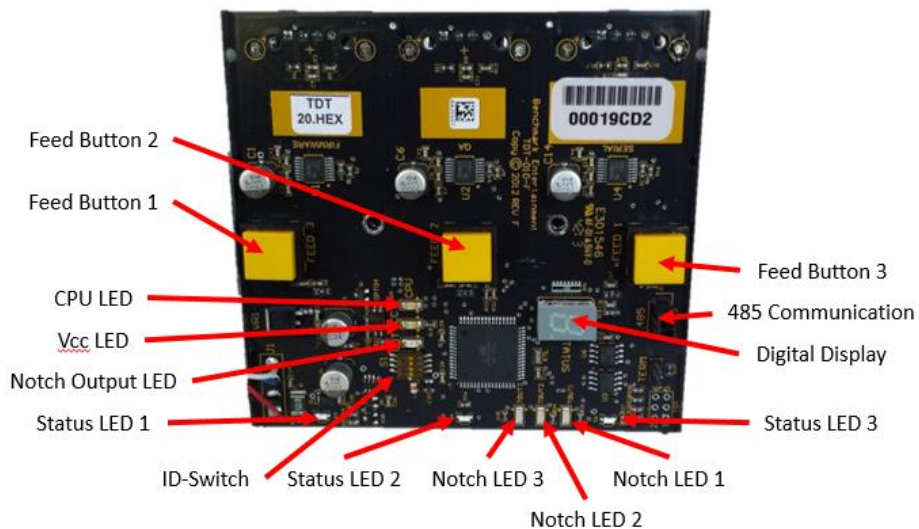

## TECHNICAL OPERATION

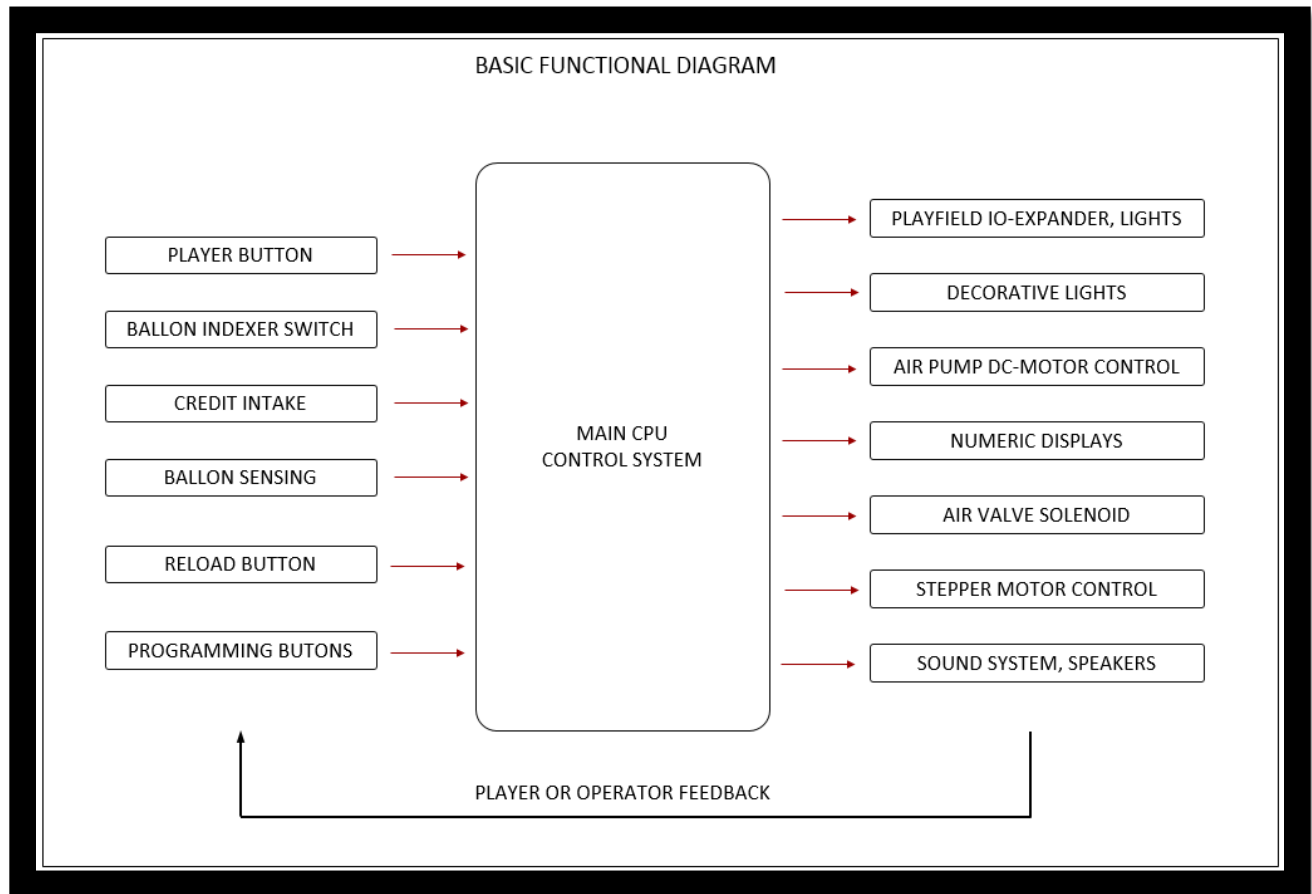

### ***Inter-Board Communication: 485 Serial pair***

The Circuit Boards communicate with each other using a 485 differential wire-pair network, using the SNAP software protocol layer.

- On this machine, this wire pair has colors Blue and Gray.
- The Main CPU Board acts as the master, initiating commands and receiving responses from the slave boards.
- Like-boards differentiate from each other by means of an ID-Switch setting.
- See the previous pages to find each board's ID-Switch location and setting.

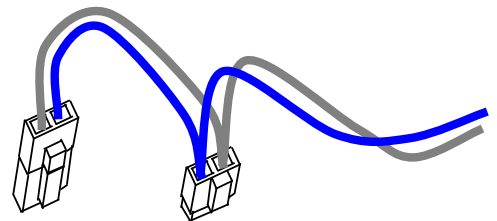

Note that we indicate the required on-off state of each micro switch in the previous pages with **1**'s and **0**'s, respectively.



- The following PCB boards are NOT connected to the 485 network:

- The Power distribution board
- The small Input Filter board
- The Air pump motor driver board
- The Playfield slave IO-expander boards
- The Ticket Dispensers



-Note that the 485 network wire-pair chain jumps from board to board:

- In some places the chaining is done by double-crimps at the connector (these are usually 2-pin connectors)
- In other places, PCB traces on the board itself carry the chain from a pair of connector pins to the next (usually a four-pin connector); thus, disconnecting such a board's 485 might actually disconnect the rest of the 485 chain. Keep this in mind when troubleshooting or replacing parts.

#### **485 Communication, network daisy chain:**

##### **Control Panel:**

Main CPU (BMC-001-B) (Daisy chain start)

- Sound Board
- IO-expander-1
- Quad Stepper
- Main-1 interface connector

##### **P1:**

- Player Credit display
- Playfield IO-Expander (up on game roof assembly)
- Marquee IO-Expander
- Back down to meet control-panel harness interface connector.

### ***Balloon Sensor Verification***

The balloon is detected by means of an ultrasound range sensor located directly under it, behind the saw-blade assembly. The ultrasound pulse travels to the balloon and gets reflected downwards. The sound's echo time is measured by the main CPU, which can then determine the balloon size.

The green LED on the sensor board should flash about twice per second, for each balloon measurement pulse.



To verify the operation of the sensor, go into Programming-Mode and select option 17, for balloon sensors. The LCD display will show you the current % of inflation for the balloon. You can even manually test this with your hand, by placing it up and down above the sensor. If everything is functional you should see the % number update about every 0.5 Sec, with values between 0% and 100%.

If the green LED on the sensor does not flash consistently, or is constantly ON, it is a sign of a malfunction on the sensor, the wiring, or the main CPU.

In case you see a problem, the recommended procedure is to first swap the two sensors across the two game cabinets. If the problem moves with the sensor, then it is the likely culprit. If the problem remains on the same cabinet side, then the problem may lay in the wiring or main CPU board.

See the troubleshooting section for more information.

Additionally, make sure the sensor is correctly placed, pointing upwards, with an angle of up to 5degrees, so it points a little towards the center of the balloon. This angle should not be excessive (10 degrees or more) as the sensor may get reflections from the spinning saw blade, throwing of the readout. Also make sure the debris guard above it is not blocking the receiver or transmitter cylinders.

### ***Balloon reload operation***

Pop It & Win uses a carrousel indexer to move the balloon locations in sequence, as they are consumed. The ratchet mechanism on the back is advanced by the stepper motor at the top-right of the cabinet. The main program knows one cycle turn has advanced thanks to the switch next to the stepper motor, when it sees this signal it stops right away to ensure the position of the assembly with respect to the solenoid air valve stays accurate.

Note that this ratchet mechanism allows for free manual motion only in the counter-clockwise direction, if you attempt to move it clockwise, you will encounter the resistance of the lever arm.

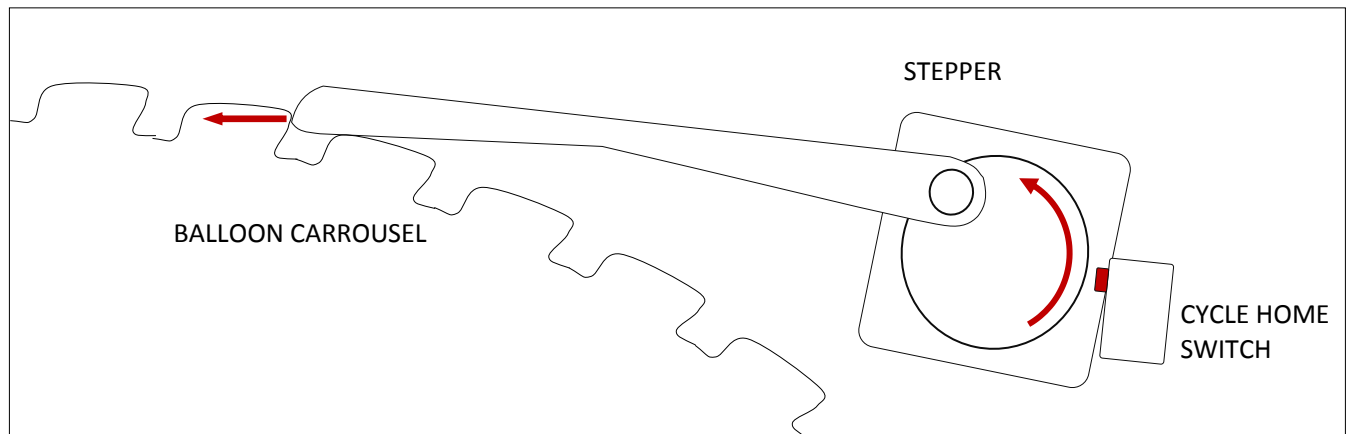

When the game detects the current balloon has disappeared (i.e. popped), it initiates the following sequence:

- Opens solenoid air-valve, this frees up the carousel and allows any incidentally present balloon to deflate.
- Double checks balloon is really gone (see balloon detect sensor section).
- Initiates an indexer position advance, as described in the first paragraph.
- Lever arm closes cycle home switch when done, motion is stopped by main program.
- Closes solenoid valve over new balloon stem position.
- Initiates balloon pre-inflation sequence, to bring air volume to the minimum level required for game-play.
- Once sufficient air volume is reached, the reload operation is complete. The game will go into play mode whenever credits are present.

#### ADDING NEW BALLOONS

The machine will automatically try up to three times to position and inflate a new balloon. If the third attempt fails, it is assumed the machine has ran out of balloons and an 'Out of Balloons' warning/fault is thrown. No further money or game-play will be accepted.

To add new balloons to the carousel wheel:

- Press the reload button to let the game know you'll be adding balloons. Any game or pump operation will stop so you can work freely.

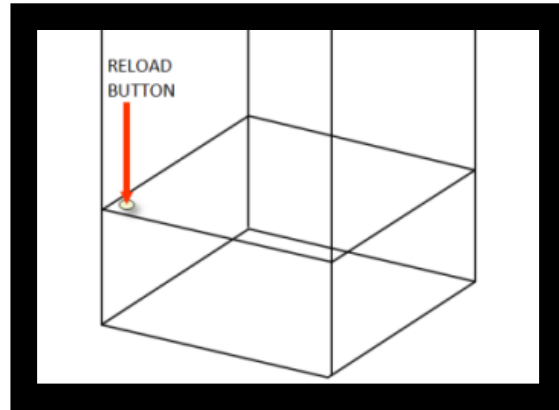

- Clear any leftover pieces from the carousel wheel.
- To be able to move the wheel around and place all the balloons, move the air valve cam slide to the side, to lock the air valve open, this frees up the balloon carousel wheel. Remember to move the wheel only in the counter-clockwise direction, since it has a ratchet action above.

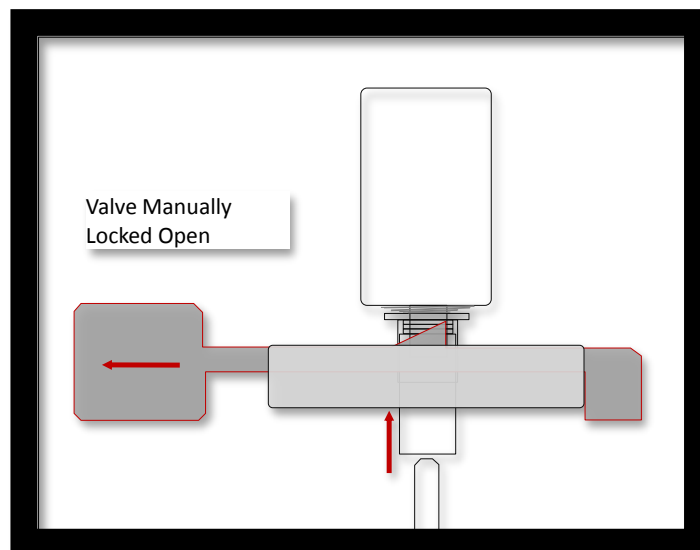

- When you're done replacing balloons, move the cam back to the right, to let the solenoid have its normal up-down movement. Make sure the valve comes back down in alignment to one of the wheel air stems (but it does re-align itself on its own if you don't do it).
- Finally, press the reload button again, to let the game know it can restart operation. You'll hear a confirmation sound, and the first balloon available will get inflated.

***Solenoid valve operation, assembly, adjustment***

The Solenoid valve assembly controls the flow of air from the air-pump to the balloon.

When the solenoid is off, the valve is closed, allowing air to go to the balloon. It also holds the carrousel in the current position. When the solenoid is energized (On), the valve is open, allowing air to escape the balloon and deflate. It also allows free movement of the carrousel, so that a different balloon location can be set.

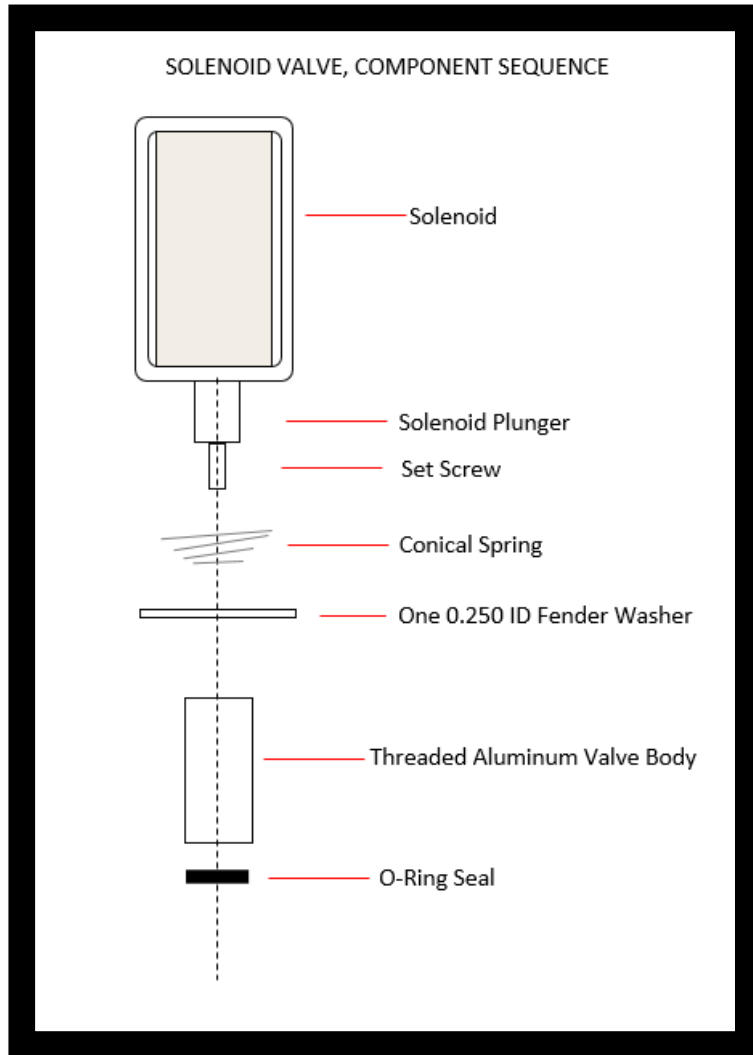

The solenoid assembly has a specific order of assembly, as shown in the image above. The larger washer limits the downward and upward motion.

The lower screws holding the assembly's plastic bracket can be loosened to adjust the height of the solenoid, in order to obtain the correct distance to the balloon carrousel.

For the Height adjustment, proceed as follows:

- 1- Make sure the solenoid is secure to the acrylic bracket.

- 2- Separately, assemble the rest of the parts, the solenoid plunger, springs, and washers. Screw-in the aluminum valve body tightly to the plunger.
- 3- Insert the assembly into the through-hole on the black plastic base support, fastening the bracket with the bottom screws, but leaving it loose enough to perform the height-adjustment.
- 4- For the height adjustment, the objective is to obtain a  $1/16''$  to  $3/32''$  gap between the valve and the stems on the balloon carousel. Verify the air gap by holding the solenoid assembly fully compressed (fully Open position) by hand, or by simply sliding the solenoid-lock lever (not shown in picture here, see balloon reload section). You may want to use some plastic stock to gauge the air gap. Tighten the bracket screws to secure the solenoid at the right height.
- 5- The hole on the plastic base is slotted so you can also adjust the front-to back position of the assembly, to make sure the valve lines-up with the stems. Tighten up the screws/nuts to secure the assembly when done.
- 6- Double check the carousel can rotate around freely, while compressing the solenoid/valve assembly, making sure the gap stays consistent. Also ensure the valve seals properly over the stem when in the down position.
- 7- Note that placement of the nylon air fitting and air hose on the side of the valve, if necessary, is done only afterwards.

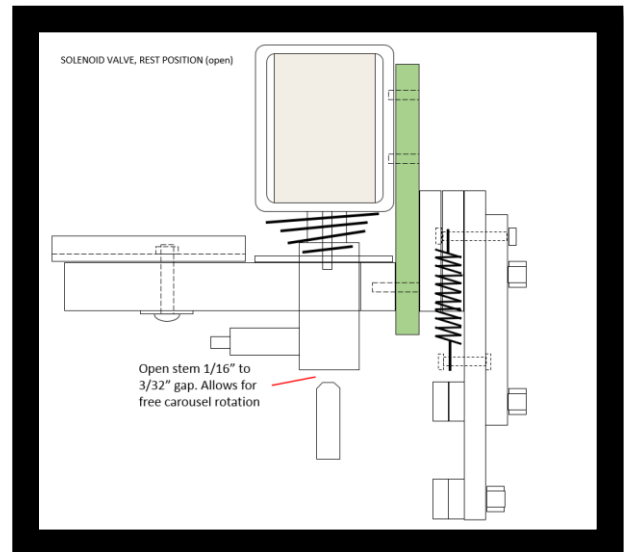
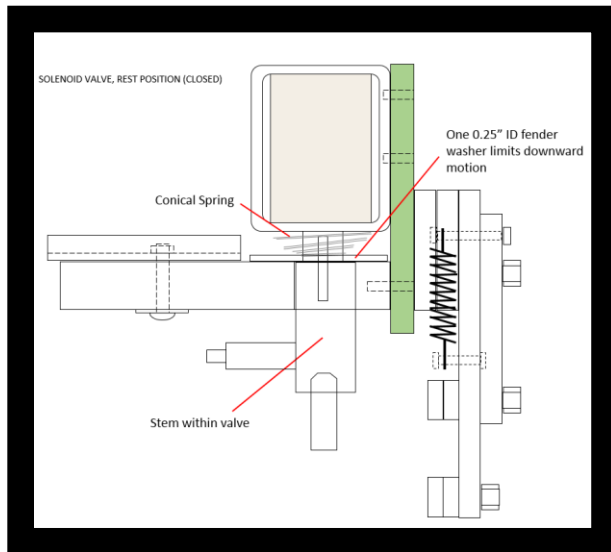

### ***Balloon Indexer, Travel adjustment***

The balloon indexer travel must be adjusted in such a way that the full stroke of the actuation arm positions the Indexer stems exactly under the solenoid valve for each turn of the indexer motor. This is done by moving the stepper motor bracket along the adjustment slots.

Proceed as follows:

- 1- Position the solenoid valve over one of the wheel stems and center it properly. If necessary, lift the actuator arm on the back so the wheel can move more freely.
- 2- Loosen the three screws on the stepper motor bracket. Rotate the motor so that the actuator arm reaches its furthest position to the left. Slide the motor bracket so that the tip of the actuator arm is just against the corresponding tooth on the wheel. Make sure the air valve stays well centered over the stem while you do this.
- 3- Tighten the bracket screws to affix this setting.

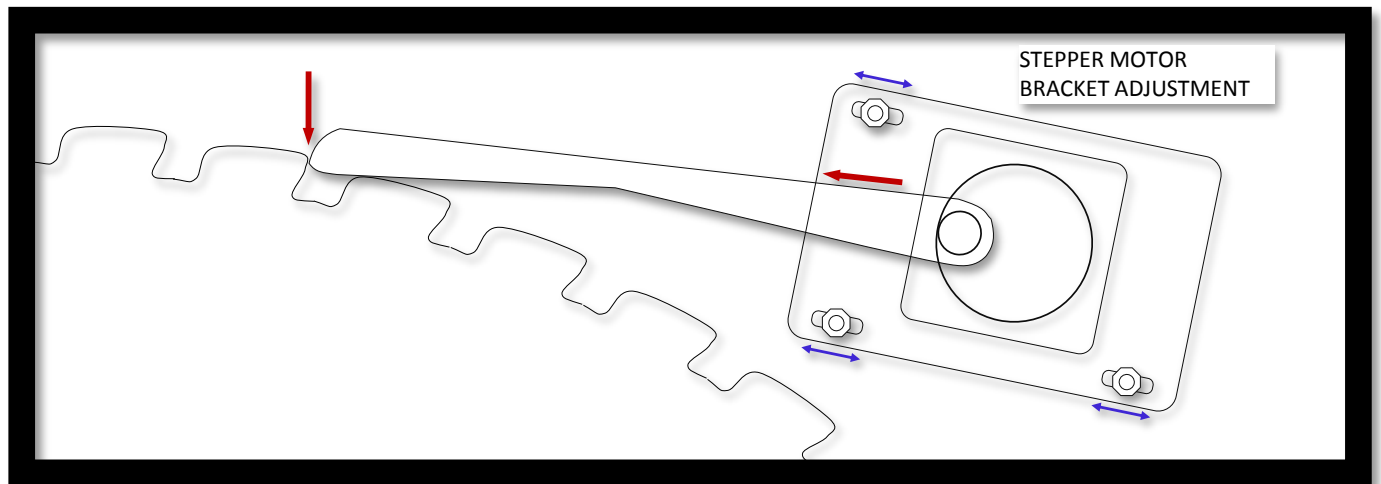

# Valve Assembly Adjustment

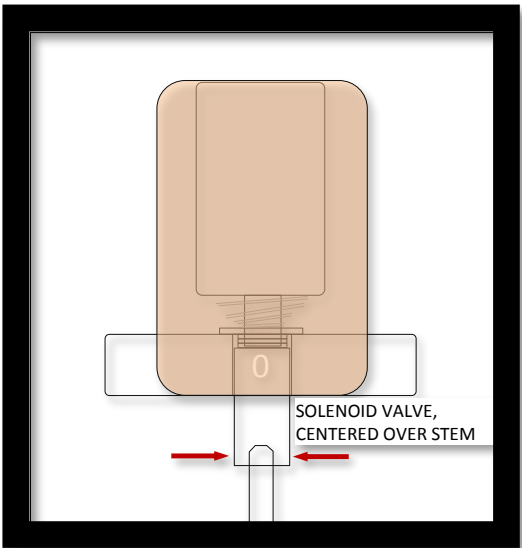
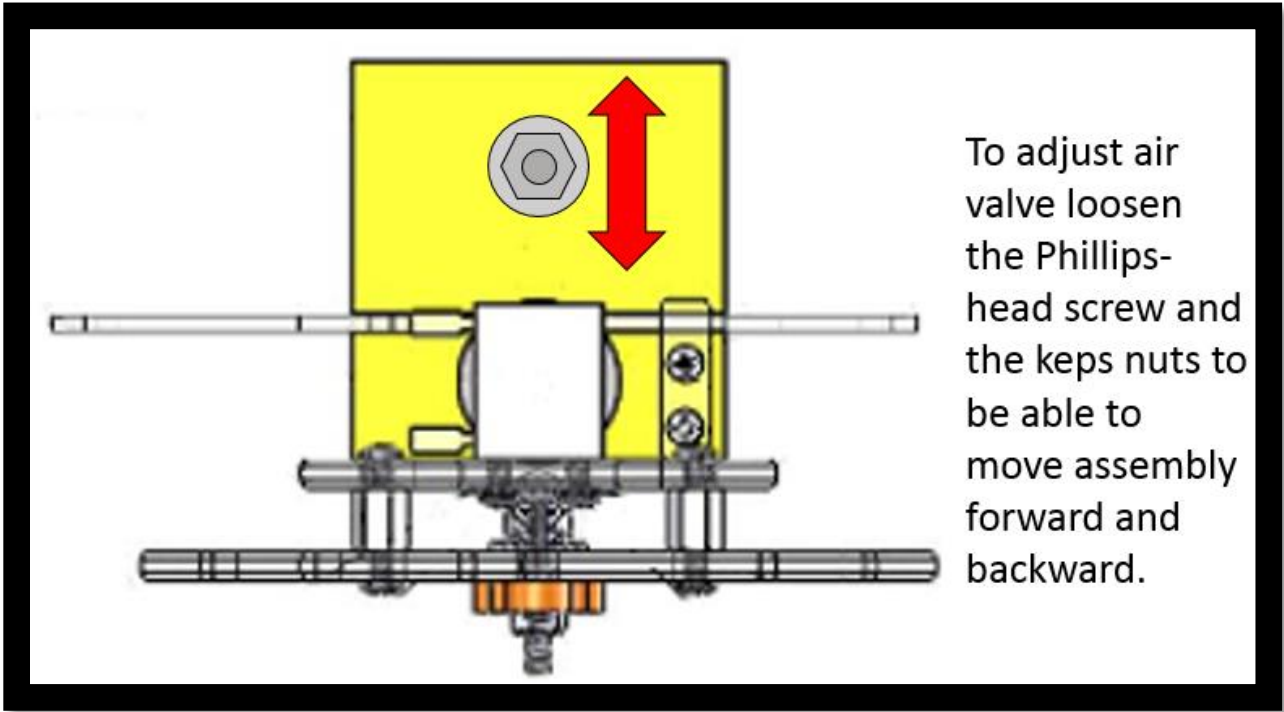

## Air-pump operation, maintenance, adjustment

### Pump Operation

- The air pump is a piston type with passive valves. It uses a check valve just after the pump to retain balloon pressure. A DC motor is used to drive the pump via a timing belt.

### Lubricating the cylinders

**Caution: This lubrication maintenance should be down with the machine powered off.**

- The life of the piston rings can be increased by keeping the cylinders lubricated. Rub the lubricant supplied with the machine (also used to lubricate the Benchmark Games ticket dispenser gears) on the inside of the cylinder walls. Rotate the center pulley so that the piston is toward the end of the travel to allow access to most of the cylinder. Lubricating no less than monthly will maximize ring life.

### Belt Adjustment

- The timing belt tension is adjustable by loosening the (3) pump bracket attach screws, pivoting the pump bracket to adjust, and retightening the pump bracket attach screws.
  - i. Do not over tighten the belt. The belt should be adjusted to just take up the slack in the belt so that the belt does not skip teeth while operating.

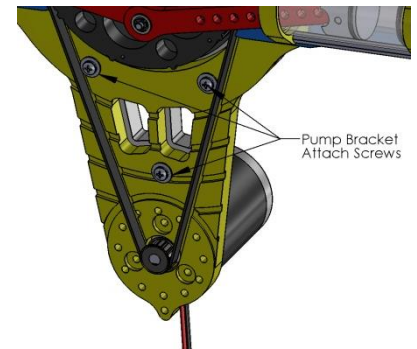

### Replacing Cylinder Rings

1. Remove E-clip retaining ring from the crank journal where the connecting rods attach to the timing belt pulley.
2. Carefully lift the connecting rod off of the crank journal.
3. Slide the piston assembly out of the cylinder by pulling the connecting rod.
4. With a narrow object such as a razor blade, carefully pry the piston ring out of the groove in the piston.
5. Replace ring by stretching over the end of the piston and into the ring groove.

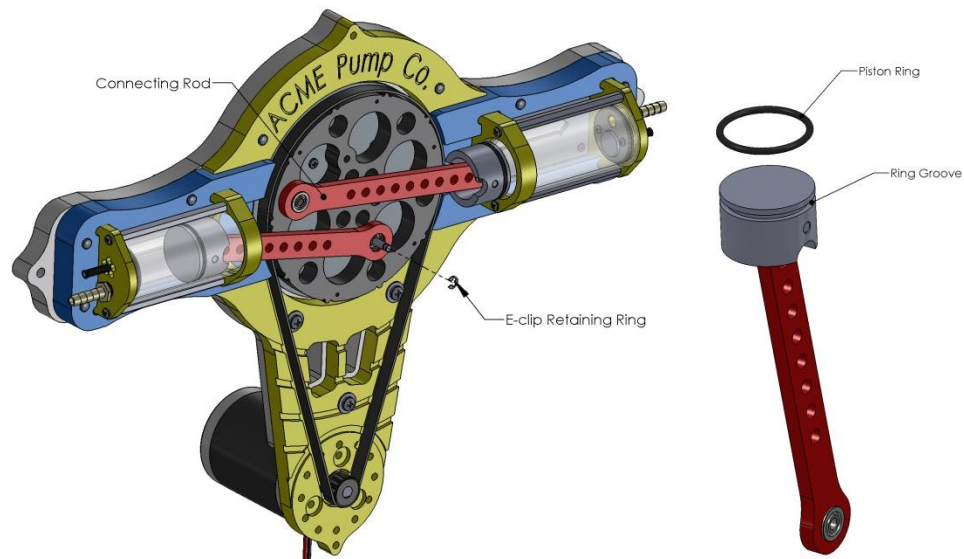

## PROGRAMMING OPTIONS

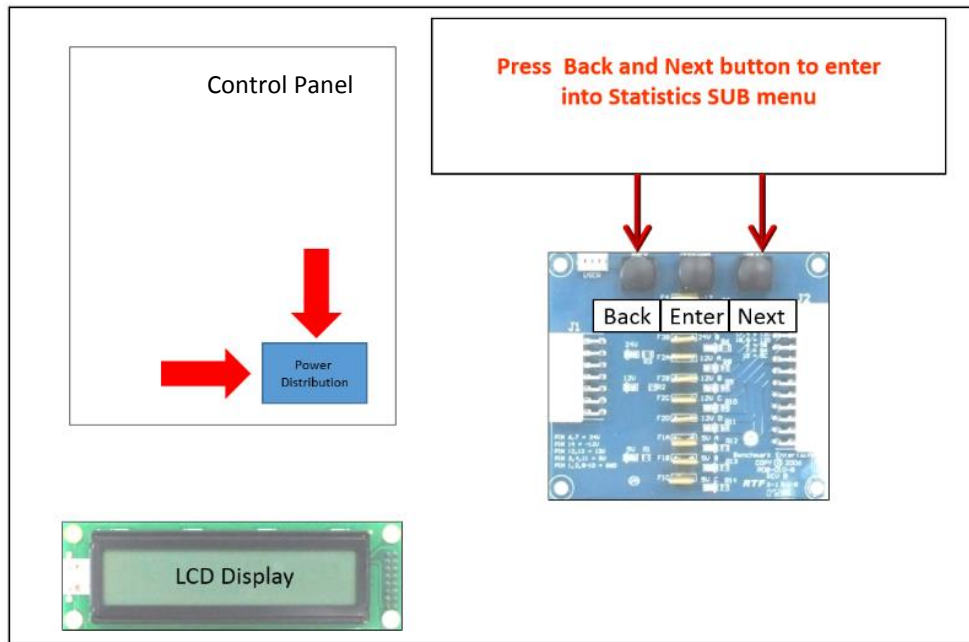

To enter Programming mode, press the Enter button on the Power Distribution Board, by reaching down to the board in the Control Panel, on the right, as shown in figure.

The LCD Display will ask you to confirm attempt to enter Programming mode. Press the enter button again to say “yes”, press the left or right button to say “no”

The LCD Display will then ask for your password. If you have not yet set a password different from the default settings the password is 0000.

The menu is followed in a sequential order, by using the side buttons to scroll and the center button to enter into the options displayed.

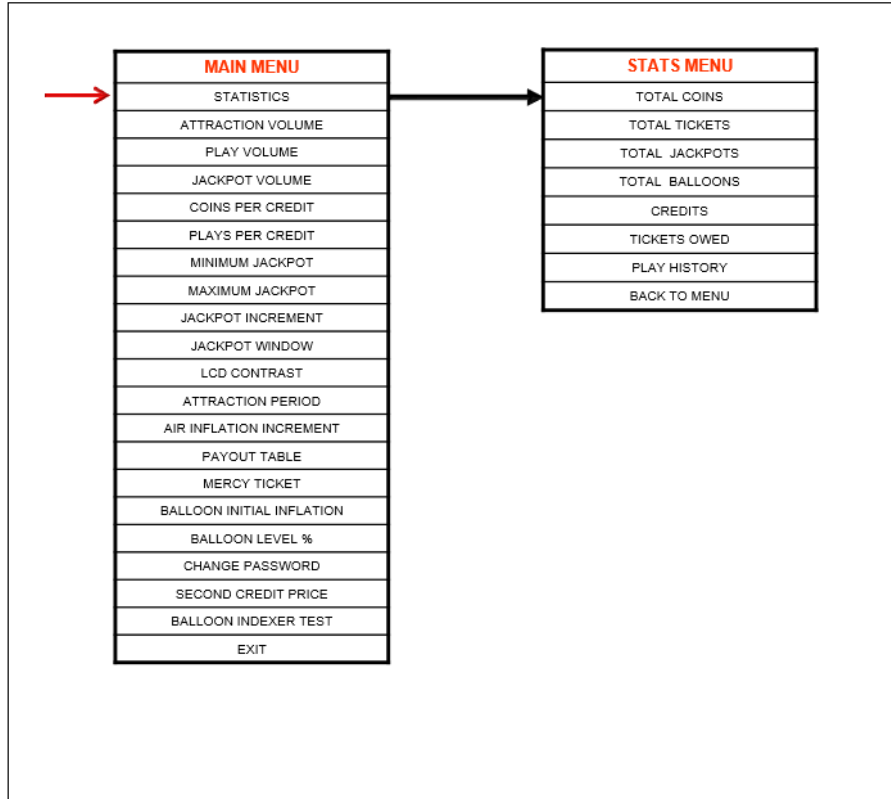

## **PROGRAMMING MAIN MENU**

### **1- STATISTICS**

*Enters the sub-menu that shows statistics values.*

### **2- ATTRACTION VOLUME**

Background music volume, when outside of play mode

Value Range: 0-100 Default: 25

### **3- PLAY VOLUME**

Background music and event volume, when Player has credits.

Value Range: 0-100 Default: 40

### **4- JACKPOT VOLUME**

Background music and event volume when a Player pops a balloon, regardless of it being through the Jackpot or not.

Value Range: 0-100 Default: 80

### **5- COINS PER CREDIT**

The amount of Coin-Mech. pulses required to add +1 credit.

Value Range: 0 –10 Default: 2 note: '0' is meant as a demo-mode, when showcasing the game.

### **6- PLAYS PER CREDIT**

The amount of play-tries are allowed per each purchased credit.

This allows to set for example: 3 tries for \$1, etc.

Value Range: 1 – 10 Default: 1

**7- JACKPOT MINIMUM**

Initial-value for the common Jackpot. (Note: each unit represents one ticket)

This value is set after the last Jackpot is awarded.

Value Range: 100 – 1000                      Default: 320

**8- JACKPOT MAXIMUM**

Limit-value for the common Jackpot. (Note: each unit represents one ticket)

Credits after this value is reached won't increment it further.

Value Range: 500 – 1000                      Default: 1000

**9- JACKPOT INCREMENT**

Amount by which the common Jackpot increases with each coin added.

Value Range: 1 – 20                      Default: 1

**10- JACKPOT WINDOW**

The width of the win-window. Higher values make it easier to win the jackpot.

Value Range: 1 – 20                      Default: 4

**11- LCD CONTRAST**

Adjusts the operator LCD display by the control panel.

Value Range: 1 – 20                      Default: 5

**12- ATTRACTION PERIOD**

Time period before the lively attraction sequence is played, to attract customers.

Value Range: 5 – 60    x1minutes    Default: 5

**13- AIR INFLATION INCREMENT**

Proportion by which air inflation is added to the balloon when targets are hit. All target x1, x2, x3, etc. 'crank' air times are proportional to this setting.

Value Range: 0-10                      Default: 3

**14- PAYOUT TABLE (ARTWORK VALUES SHOULD MATCH TABLE)**

There are five payout tables to choose from, according to your play price:



Note: For low cost setups that run \$0.25 play, the other jackpot and air inflation settings are run at lower values, to keep payout proportionate to play.

Value Range: A-D            Default: A

#### **15- MERCY TICKET**

In some jurisdictions, a minimum return of tickets is required. This allows you to set that amount.

Value Range: 0-10            Default: 0

#### **16- BALLOON INITIAL INFLATION**

Initial level of inflation for new balloons.

Value Range: 1-20            Default: 10

#### **17- BALLOON SENSOR LEVEL%**

This entry shows you the current % inflation of the balloon, as detected by the balloon sensor in real-time. It comes in handy to verify proper operation.

Value Range: 0-100%        if sensor is disconnected or faulty, this will read as "Sensor Disconnected".

#### **18- CHANGE PASSWORD**

Allows you to change the programming mode entry-password. You will be asked for a confirmation.

If you lose your password, you can call customer service for assistance.

#### **19- BALLOON INDEXER TEST SEQUENCE**

This is a sequence that tests all 60 balloon indexer positions for proper seal. The Pop-it & Win will attempt to inflate a balloon on each position until it is seen by the balloon-sensor at the bottom. If the position fails to inflate the balloon, the test will stop to show the tech which position failed. The tech will then have to restart the test to ensure that all 60 positions are acceptable. The test will proceed until a seal fails. If there is no fails Pop-it & Win will continue to test until manual override. To exit after the test-end and go back to the menu, press the 'Enter' programming button.

- Note that you may also end the test early by pressing the 'Enter' button. The machine will finish testing the current position and then it will end the test sequence.
- If the machine experiences an error when attempting to turn the wheel, it will end the test and exit programming mode.

The issue with the wheel must be solved first, before testing the balloon positions.

#### **20- SECOND CREDIT PRICE (SELECTED JURISDICTIONS ONLY)**

In some jurisdictions, the second credit purchased must be discounted, to a programmed value.

This option is not visible in regular versions of the firmware.

Value Range: 0-10            Default: 0

#### **- EXIT**

Back to normal game operation, balloon-reloading or game-play will resume.

### **STATISTICS SUB MENU**

### ***TOTAL COINS***

Total including both games.

Hit 'Enter' to take this back to zero (you will be prompted for confirmation).

### ***TOTAL TICKETS***

Total for Player 1. Separate Ticket total allows estimation of Ticket Dispenser service schedule.

Hit 'Enter' to take this back to zero (you will be prompted for confirmation)

### ***TOTAL JACKPOTS***

Total including both games.

Hit 'Enter' to take this back to zero (you will be prompted for confirmation).

### ***TOTAL BALLOONS***

Total for game.

Hit 'Enter' to take this back to zero (you will be prompted for confirmation).

### ***CREDITS***

How many credits are present on the game.

Hit 'Enter' to take this back to zero.

### ***TICKETS OWED***

How many tickets are still due by the corresponding Ticket Dispenser device.

Hit 'Enter' to take this back to zero; Ticket Dispenser will stop.

### ***PLAY HISTORY***

You can see the last five game results for the corresponding player (the left-most is the oldest one). These uses the following result symbols

" \_ " = blank entry (usually when machine first used or settings have been reset).

Number = Ticket-award determined by payout table.

JK! = Jackpot

### ***BACK TO MAIN MENU***

Goes back to the initial options list.

## **ALTERNATIVE COIN AND CARD-SWIPE SYSTEM CONFIGURATIONS**

There are a several alternative Card Swipe systems configuration possibilities, depending on your location. These are described in a general fashion as follows.

Note that the system expects the following timing ranges for any pulses:

Low time: 40-80ms

Up time: 100-150ms

## **CARD SWIPE SYSTEM**

The Coin-Mech. can be replaced to set up a swipe-for-credits, or e-tickets scheme.

This is the recommended set up:

- Remove the Coin-Mech. and install your card swipe systems in the lower front door.  
[Contact customer service if custom plastic plates for this purpose are required].
- Some of the necessary signal lines are available on the connector at the door hinge:
  - Enable signal, output.
  - Coin-in line, input

For the 'Run' and 'Notch' signals, you can tap directly from the lines on the Ticket Dispenser drawer, or from the following pins at the main to control harness connection (24pin minifit)

Ticket Notch: Blue wire on pin 23 (make sure not to grab the blue 485 wire or the stepper controller wire)

Ticket Run: white wire on pin 11

- Have your card swipe system tap into the Coin signal line.
- Configure your card swipe system for a 1-pulse-per-swipe response.
- If tapping the coin signal line (Gray/yellow), 1 pulse (swipe) will count as 1 coin internally.
- Configure the game to provide the necessary credits for the 'coin' count indicated above and the actual money you will charge per-swipe.
- If possible (strongly recommended), hook up your system to the enable line (Blue/green), so that the game can stop money intake in case of any machine error or fault.

## **COIN MECHS**

It is possible to use other coin mechanisms on this machine. The wiring harness terminates on both Spade-type connectors and an IDC connector for this purpose, the signal lines are:

# Wire Color	Signal
1 Yellow	12V
2 Gray-Red	Coin Signal
3 Blue-Green	Enable (low=enable, high=disable) (this should be hooked to Coin-Mech. ground)
4 Black	GND, actual DC Ground

#### Notes:

The 'Device Ground/Enable' line comes from the IO-Expander 3 Board, as commanded by the main CPU to enable or disable money intake. It is necessary that your Coin-Mech. device has a coin-lock 'reject' solenoid so that this feature is available.

Normally, for an Imonex, if it has a coin reject solenoid, you hook the solenoid's 'ground' to the enable line, so that the game can control it.

For an electronic Coin-Mech., like the MPU, you hook up the Coin-Mech.'s 'ground' to the enable line.

## ERROR CODES AND TROUBLESHOOTING GUIDE

### *ERROR CODES, QUICK SUMMARY*

Shown on the LCD and corresponding 4-digit credit display, or jackpot display.

- E1: IO-Expander Columns, Communication Error.
- E2: IO-Expander Playfield, Communication Error.
- E3: Out of Tickets
- E4: IO-Expander Marquee, Communication Error.
- E6: Sound Board, Communication Error.
- E7: Credits Display, Communication Error.
- E8: Jackpot Display, Communication Error.
- E9: Quad-Stepper, Communication Error.
- E10: Out of Balloons.
- E11: Balloon Load Error.

### **TROUBLESHOOTING GUIDE**

Following a methodical approach will make it easier for you to resolve issues with any type of equipment. In most cases, machinery consists only of a set of input signals, a process for those signals, and some resulting outputs. Separating the system into these three areas lets you have a clear map when looking for solutions.

In general terms, to isolate a fault, you usually follow these steps (not necessarily in this order):

1. INPUT (from button switch, etc.)
  - Determine if the related input signals (i.e. button, etc.) are reaching the processing stage, usually a PCB board.
  - Determine if its related input signal reaches the control system (i.e. board), by measuring continuity in the wires.

- If there is still some doubt on the consistency of the connection, you can ground the input on the board directly, by removing the connector in question and using a small wire to bypass the harness and bring ground (or the appropriate signal) to it.
2. PROCESS (usually a PCB board)
- Check power is reaching the device. If it's a PCB board, it usually has a static LED light showing it's powered.
  - Check board is running, usually showing a separate flashing LED light.
  - Check the board has the right program, by checking the firmware name sticker on the board surface.
  - Swapping the board for a known-good replacement is a very common way to determine right away if it the problem lays with the board. Be mindful though, that there might be an external issue that damages the board in the first place. That's why it's important to first check the power voltage has the proper level, etc.
  - If there are more that on like-boards on the machine, swapping them around will let you know if the problem follows the board or if stays with the assembly section.
3. OUTPUTS (to light, solenoid, motor, or another pcb board)
- Determine if the process output signals are reaching the end-device
  - Measure continuity on the wires from the output of the PCB board to the end device.
  - If there is still some doubt regarding the connection, try activating the device directly by disconnecting the outputs connector from the board, and using a spare piece of wire to feed it the proper signal.
- For example, disconnecting the hi-current output board and feeding ground to one of the output pins on the harness side, to activate a solenoid directly for a brief moment.
- Like in the other examples, swapping the device for a known good unit also helps in narrowing things down.

SYMPTOM	POSSIBLE CAUSES / ACTIONS
It doesn't work	Multiple. Plug the game to a wall receptacle and determine more exactly what features don't work.
E1 Error Code: IO-Expander 1 Communication Error	<p>Most likely Column light-strips will behave erratically or will show nothing at all.</p> <ul style="list-style-type: none"> <li>➤ Check board has power, Vcc-LED should be lit.</li> <li>➤ Check board program is running, heartbeat LED should be flashing slowly, fast when receiving 485 serial comm. commands.</li> <li>➤ Check board firmware label for "IO-EXP GENERIC" code.</li> <li>➤ Check on-board ID-switch setting, as per PCB board section</li> </ul> <p>Note that relevant 485 traffic makes the green LED flash quickly as messages are received, check for this as well.</p> <ul style="list-style-type: none"> <li>➤ Check 485 communication connector for proper crimping and polarity (try flipping 485 connector or its pins.</li> <li>➤ Check that all boards are connected to the 485 network, remember that in some of them, a disconnection will break the rest of the 485 chain.</li> <li>➤ Check 485 communication connector on Main CPU Board</li> <li>➤ Check continuity for the blue and gray wires all the way from the main CPU board</li> <li>➤ Try grounding the lights directly by disconnecting the outputs J3 connector from the board and using a small wire to give ground to each line on the connector.</li> <li>➤ Swap for known good unit to see if problem follows board.</li> </ul>

<p>E2 Error Code: IO-Expander Playfield Communication Error</p>	<p>The three boards on top of the cabinet control the playfield lights, but only the one on the left talks to the 'main CPU'.</p> <p>With 485 comm. failure, most likely the Playfield lights will show nothing at all.</p> <ul style="list-style-type: none"> <li>➤ Check board has power, Vcc-LED should be lit.</li> <li>➤ Check board program is running, heartbeat LED should be flashing slowly, fast when receiving 485 serial comm. Commands.</li> <li>➤ Check board firmware label for "EXPLOSIVE PLAYFIELD" code.</li> <li>➤ Check on-board ID-switch setting, as per PCB board section</li> <li>➤ Note that relevant 485 traffic makes the green LED flash quickly as messages are received, check for this as well.</li> <li>➤ Check 485 communication connector for proper crimping and polarity (try flipping 485 connector or its pins)</li> <li>➤ Check that all boards are connected to the 485 network, remember that in some of them, a disconnection will break the rest of the 485 chain.</li> <li>➤ Check 485 communication connector on Main CPU Board</li> <li>➤ Swap for known good unit to see if problem follows board.</li> </ul>
<p>E3 Error code: Out of Tickets</p>	<ul style="list-style-type: none"> <li>➤ Reload tickets for the Ticket dispenser. Press reload button underneath Ticket Dispenser device to restart it.</li> <li>➤ Check power on the TD, board LEDs should be lit</li> <li>➤ If there is no power to the ticket dispenser. Measure the voltage coming in, and all the the way back to the power distribution board if needed.</li> <li>➤ Also check continuity for the Run and Notch lines coming from the Main CPU Outputs/Inputs. Remember to power down first before any continuity test.</li> </ul>
<p>E4 Error Code: IO-Expander Marquee Communication Error</p>	<p>These boards control the Left and Right sides of the overhead marquee lights.</p> <ul style="list-style-type: none"> <li>➤ Check board has power, Vcc-LED should be lit.</li> <li>➤ Check board program is running, heartbeat LED should be flashing slowly, fast when receiving 485 serial comm. Commands.</li> <li>➤ Check board firmware label for "IO-EXP GENERIC" code.</li> <li>➤ Check on-board ID-switch setting, as per PCB board section</li> <li>➤ Note that relevant 485 traffic makes the green LED flash quickly as messages are received, check for this as well.</li> <li>➤ Check 485 communication connector for proper crimping and polarity (try flipping 485 connector or its pins)</li> <li>➤ Check that all boards are connected to the 485 network, remember that in some of them, a disconnection will break the rest of the 485 chain.</li> <li>➤ Check 485 communication connector on Main CPU Board</li> <li>➤ Swap for known good unit to see if problem follows board.</li> </ul>
<p>E6 Error Code: Sound Board Communication Error</p>	<p>The sound board controls playback and amplification for both players 1 and 2</p> <ul style="list-style-type: none"> <li>➤ Check for board power (Vcc LED On)</li> <li>➤ Check board program is running, (green LED flashes slowly)</li> <li>➤ Check board firmware label for "Soundcard" code.</li> <li>➤ Check board communication-485, including on-board ID-switch setting.</li> <li>➤ Note that relevant 485 traffic makes the green LED flash quickly as messages are received, check for this as well.</li> <li>➤ Check that all boards are connected to the 485 network, remember that in some of them, a disconnection will break the rest of the 485 chain.</li> <li>➤ Check 485 communication connector on Main CPU Board</li> <li>➤ Swap for known good unit to see if problem follows board.</li> </ul>
<p>E7 Error Code: Small Credits Display 1 Communication Error</p>	<p>This is the small display by the playfield target lights</p> <ul style="list-style-type: none"> <li>➤ Check for board power (Vcc LED On)</li> <li>➤ Check board firmware label for "4dd" code.</li> <li>➤ Check board communication-485, including on-board ID-switch setting.</li> <li>➤ Note that relevant 485 traffic makes the green LED flash quickly as messages are received, check for this as well.</li> <li>➤ Check that all boards are connected to the 485 network, remember that in some of them, a disconnection will break the rest of the 485 chain.</li> <li>➤ Check 485 communication connector on Main CPU Board</li> <li>➤ Swap for known good unit to see if problem follows board.</li> </ul>
<p>E8 Error Code: Jackpot Display Communication Error</p>	<p>This is the large display above in the marquee</p> <ul style="list-style-type: none"> <li>➤ Check for board power (Vcc LED On)</li> <li>➤ Check board firmware label for "4dd" code.</li> <li>➤ Check board communication-485, including on-board ID-switch setting.</li> <li>➤ Note that relevant 485 traffic makes the green LED flash quickly as messages are received, check for this as well.</li> <li>➤ Check that all boards are connected to the 485 network, remember that in some of them, a disconnection will break the rest of the 485 chain.</li> <li>➤ Check 485 communication connector on Main CPU Board</li> <li>➤ Swap for known good unit to see if problem follows board.</li> </ul>

<p>E9 Error Code: Quad Stepper Board Communication Error</p>	<p>This board controls the balloon-indexer and saw-blade motors</p> <ul style="list-style-type: none"> <li>➤ Check for board power (Vcc LED On)</li> <li>➤ Check board program is running, (green LED flashes slowly)</li> <li>➤ Check board firmware label for “Quad Stepper Generic” code.</li> <li>➤ Check on-board ID-switch setting, as per PCB board section</li> <li>➤ Note that relevant 485 traffic makes the green LED flash quickly as messages are received, check for this as well.</li> <li>➤ Check that all boards are connected to the 485 network, remember that in some of them, a disconnection will break the rest of the 485 chain.</li> <li>➤ Check 485 communication connector on Main CPU Board</li> <li>➤ Swap for known good unit to see if problem follows board.</li> </ul>
<p>E10 Error Code: Out of Balloons Condition</p>	<p>The machine has tried three times to load a new balloon but has not found one.</p> <ul style="list-style-type: none"> <li>➤ if the balloons are really gone, place new balloons around as per section 4 -&gt; Balloon Reload</li> <li>➤ A fake condition may be present if you have been working on the machine and have physically prevented it from reloading a balloon. Press the balloon reload button inside the cabinet two times, waiting a couple seconds in between, to let the machine now it can resume reloading a balloon again.</li> <li>➤ Another fake ‘no-balloon’ condition may be present if the Ultrasonic balloon sensor fails, see the recommendations below.</li> </ul>
<p>E11 Error Code: Balloon indexer problem</p>	<p>As per section 4-&gt; Balloon reload the balloon carousel system has a switch by the motor to let it know it the valve is aligned to the balloon stems.</p> <p>If for any reason, the main CPU is unable to see the signal from this switch as the motor rotates the carouse. This Error will show up.</p> <ul style="list-style-type: none"> <li>➤ If the solenoid air-valve fails to activate when attempting to cycle to a new balloon, the machine won’t be able to rotate the wheel and the switch won’t be seen. Confirm proper activation and alignment of solenoid assembly mechanism.</li> <li>➤ Check continuity between the switch and the main CPU board input (J3-2 and J3-11 for players 1 and 2 respectively). This is easily accomplished by manually rotating the motor (with the game off) until it keeps the switch depressed, and then checking continuity between the corresponding board input and dc ground. If you have a helper, he can press the switch intermittently to better confirm the connection.</li> <li>➤ If the connection is OK, try ruling out the main pcb board (an input may have gone bad), by swapping it with known-good unit.</li> <li>➤ When in this condition, the game usually re-attempts every 5 minutes, but it is easier to reboot the machine to check your solution right away.</li> </ul>
<p>Balloon Sensor malfunction</p>	<p>The balloon sensor consists of an ultrasonic transmit-receive pair that measures the echo time of a sound-pulse traveling to the balloon and back.</p> <p>This echo-time is measured to determine the current size of the balloon.</p> <p>A failure of this sensor will be reflected as an ‘out of balloons’ error.</p> <ul style="list-style-type: none"> <li>➤ Check the balloon sensor board LED light is flashing periodically, at about two flashes per second. This means it its properly communicating with the main CPU board and that it is scanning correctly. If the light is stuck ON or OFF the sensor or the connection may be faulty.</li> <li>➤ Go to the Programming-Mode options and into the “Balloon % level” option for the corresponding side.</li> <li>➤ The LCD will show you one of the following: <ul style="list-style-type: none"> <li>▪ % amount: Connection and sensor Ok</li> <li>▪ “Sensor disconnected”: connection is lost, check wire continuity.</li> <li>▪ “No sensor response”: sensor may be connected, but response is inadequate. Swap the sensor for a known-good unit (from the other game) to confirm this.</li> </ul> </li> </ul>
<p>Playfield Lights Malfunction</p>	<p>The playfield lights are controlled by the three ‘IO-expander’ boards on top of each cabinet. The one to the left is the master light board and it talks to the ‘main CPU’ board back at the bottom of the game.</p> <p>The other two boards follow the ‘master’ lead as to which lights to illuminate. This is accomplished via a custom 5-line data bus between the boards.</p> <p>Here are some possible things to look for:</p> <ul style="list-style-type: none"> <li>➤ Make sure the ID-switches are set correctly on all three boards, as per PCB section of this manual.</li> <li>➤ Make sure all three boards are running (flashing LED)</li> <li>➤ Make sure all three boards have the correct program label , “Explosive Playfield”</li> <li>➤ Check the wires on the six pin 093 connector pair carry through with the same colors on both sides. This lines are the 5-line data bus described before. If something is wrong here, you will most likely see the bottom playfield lights be Ok, while the others present inconsistencies.</li> </ul>

Balloon leaks air	<p>Note: A small percentage of balloons will happen to leak air very slowly due to defective balloons from factory.</p> <p>If a consistent fast leakage occurs, please check the Air Valve adjustment section.</p>
-------------------	--

# AIRPUMP ASSEMBLY DIAGRAMS

