



© NHL



Air FX User Manual

Innovative Concepts In Entertainment

10123 Main street, Clarence, NY 14031

WWW.ICEGAME.COM

Table of Contents

Assembly	3-7
Maintenance	8
Playfield Warning	9
Main Board Layout	10
RGB Driver Board Layout	11 - 12
Programming	13 - 16
Deflector Layout	17
Score Display Settings	18
Parts	19 - 21
Warranty	22

Locate keys and Open

The keys are either located in the coin return of the coin door or screwed to the bottom of the cabinet. There should be two different types of keys. One set for the coin door and another to open the player's puck doors.

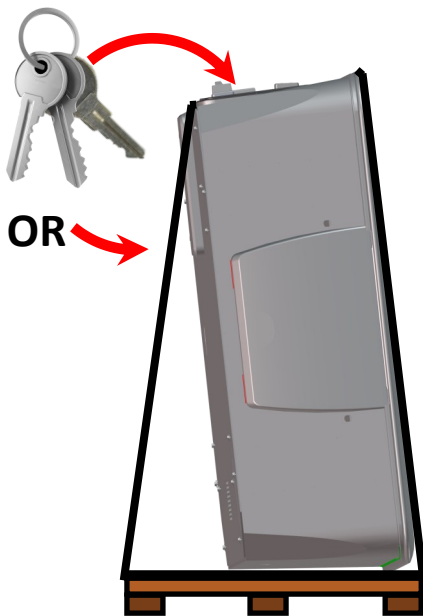

Locate the legs and feet.

The leg, feet, and hardware is located inside the right side door.

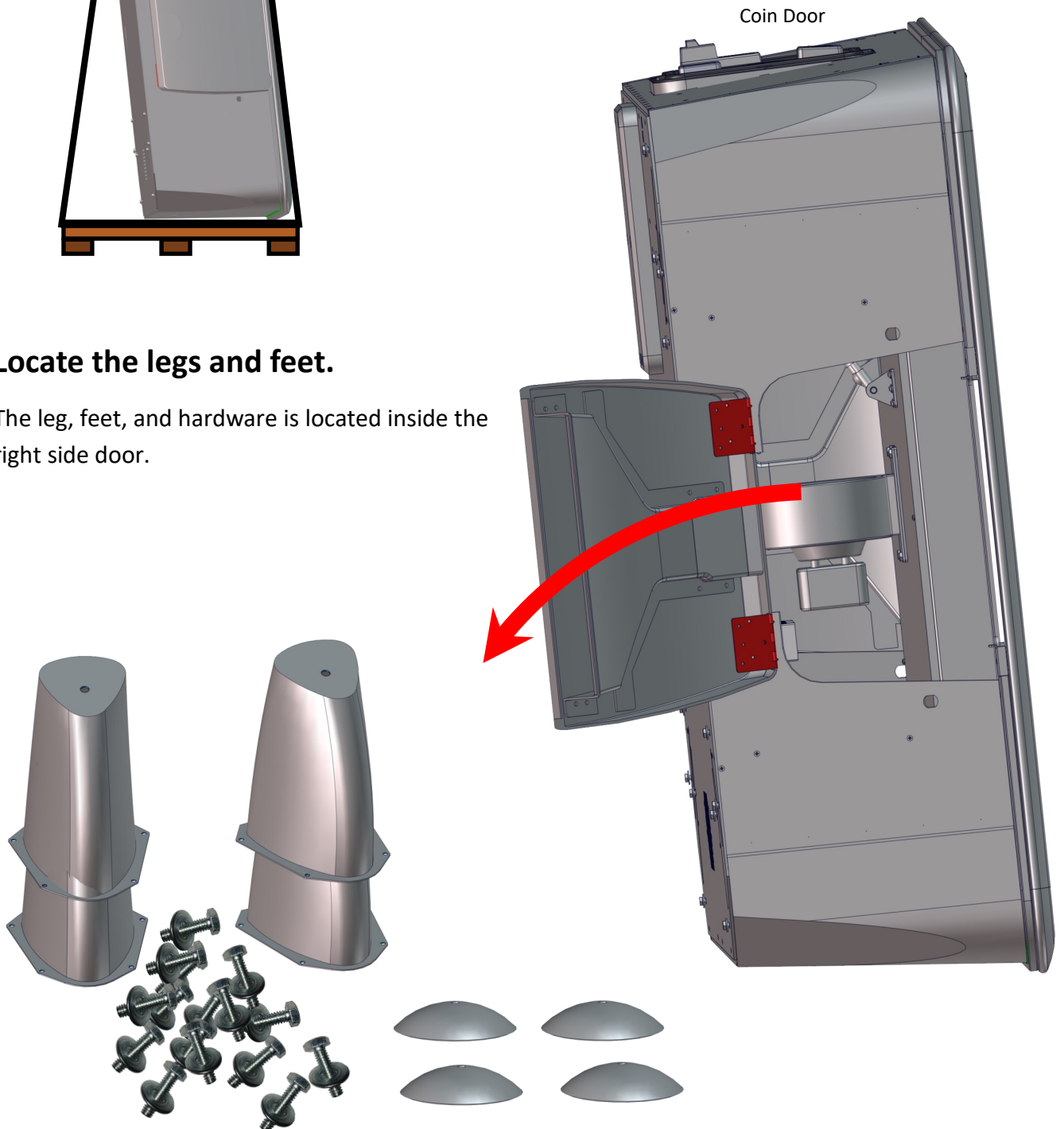

Leg Assembly:

After removing the legs from the cabinet, remove the bolt using a 6mm Allen wrench on each leg. You will have to also use a wrench to hold the adjustment rod from spinning out. Then place one feet per leg and reattach the 6mm bolt. The adjustment rods are installed from the factory and can be adjusted for uneven heights once installed to the cabinet.

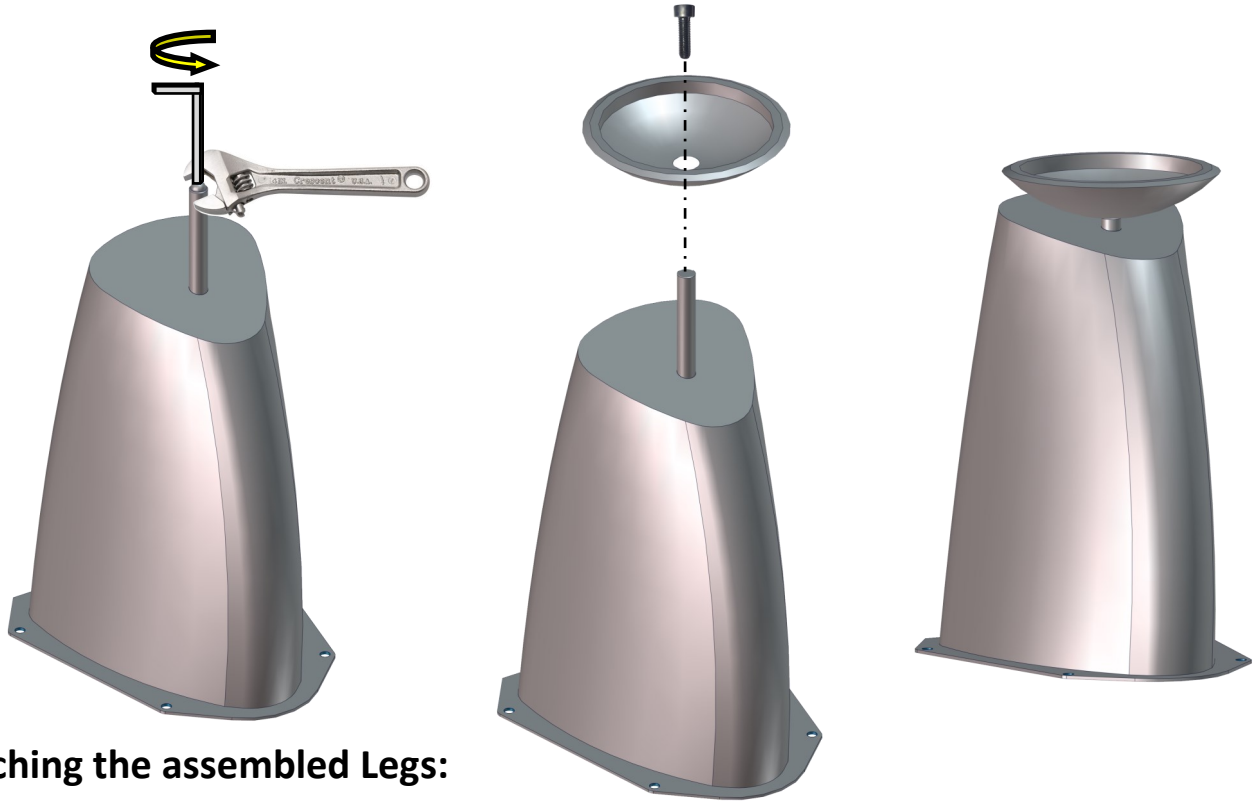

Attaching the assembled Legs:

Using four 7/16 bolts and washers attach each leg onto the bottom of the cabinet. Tighten all bolts.

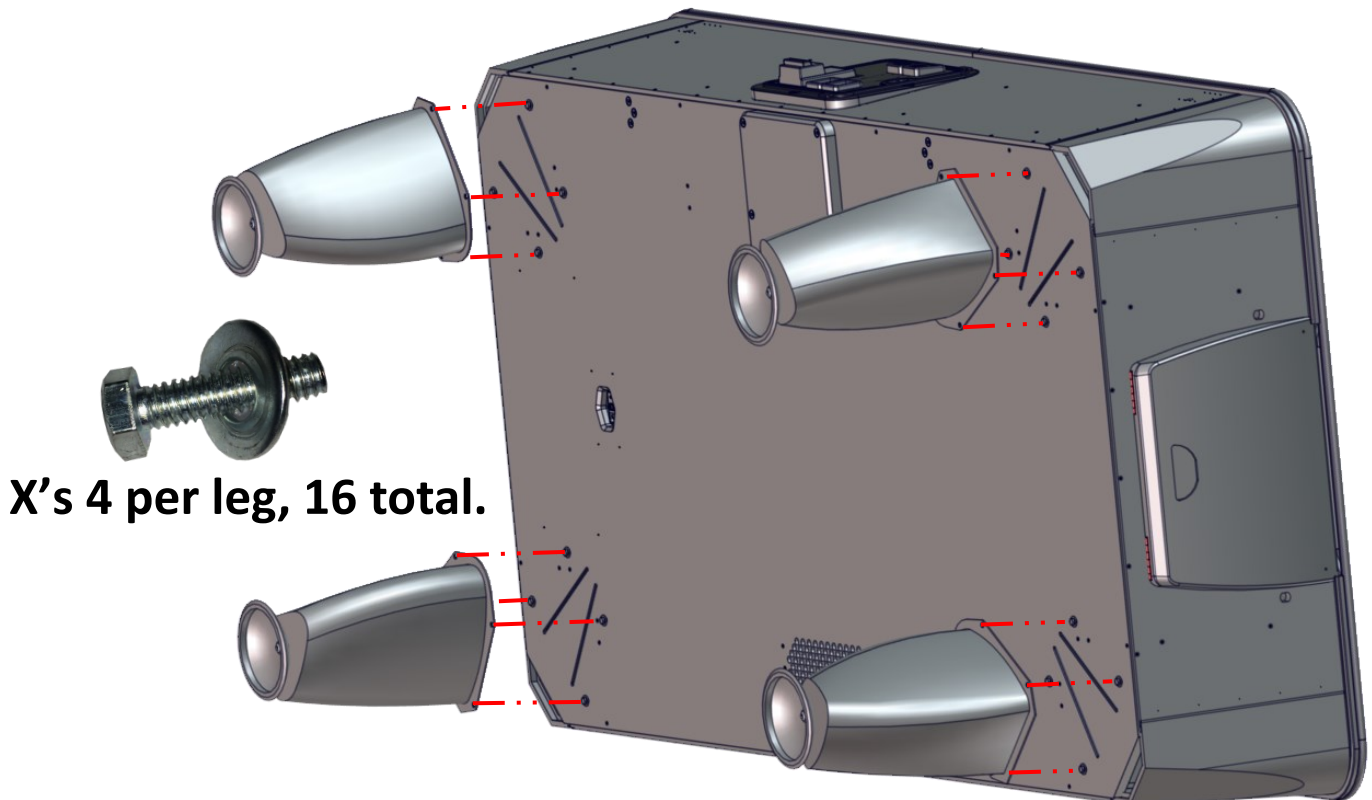

Positioning the Table

Flip the table onto its legs using at least four people on either side.

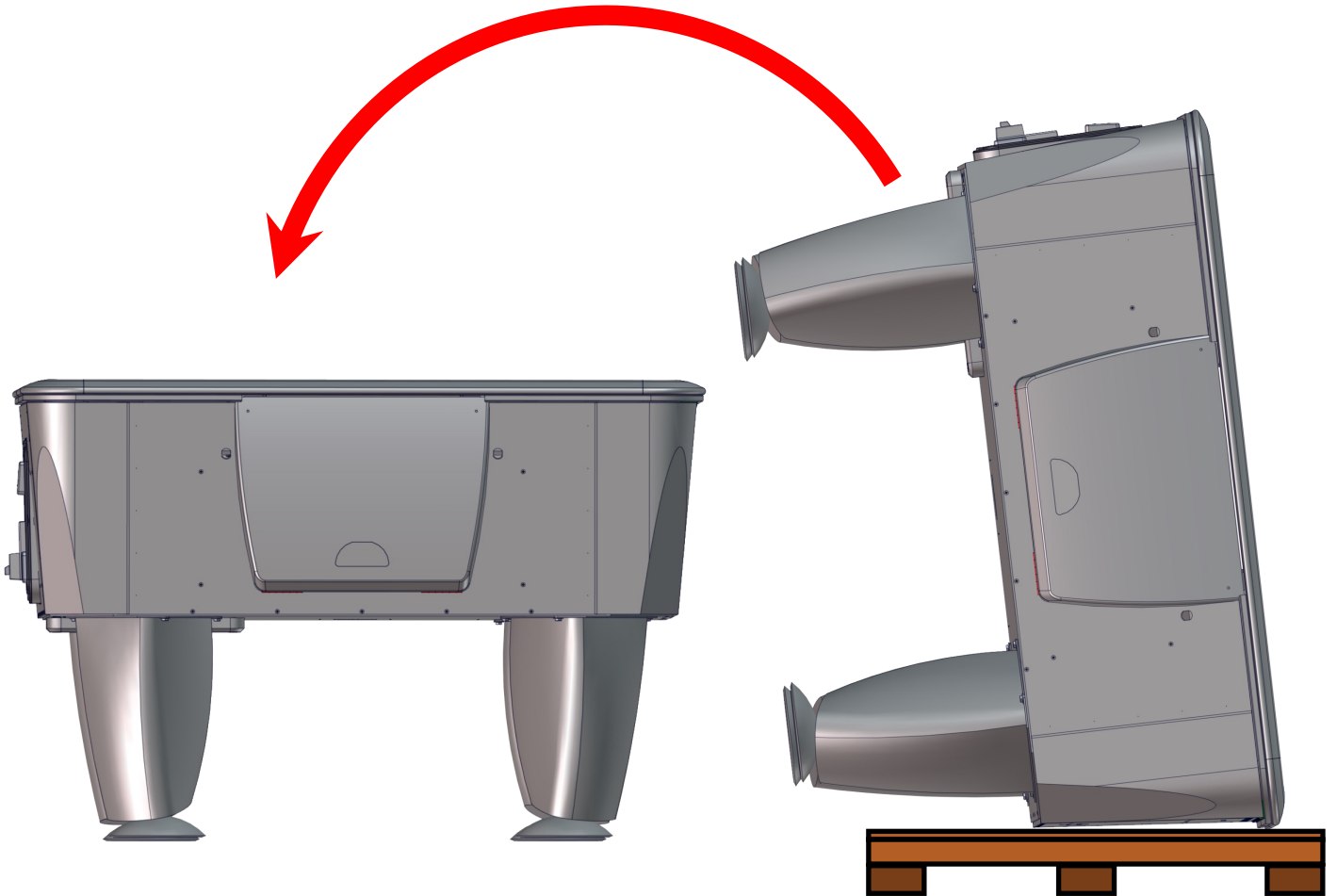

Opening The cabinet Top:

Located in the cash box is the Allen wrench key to open the cabinet top playfield. Insert the wrench as shown and turn counter-clock-wise to unlock the playfield.

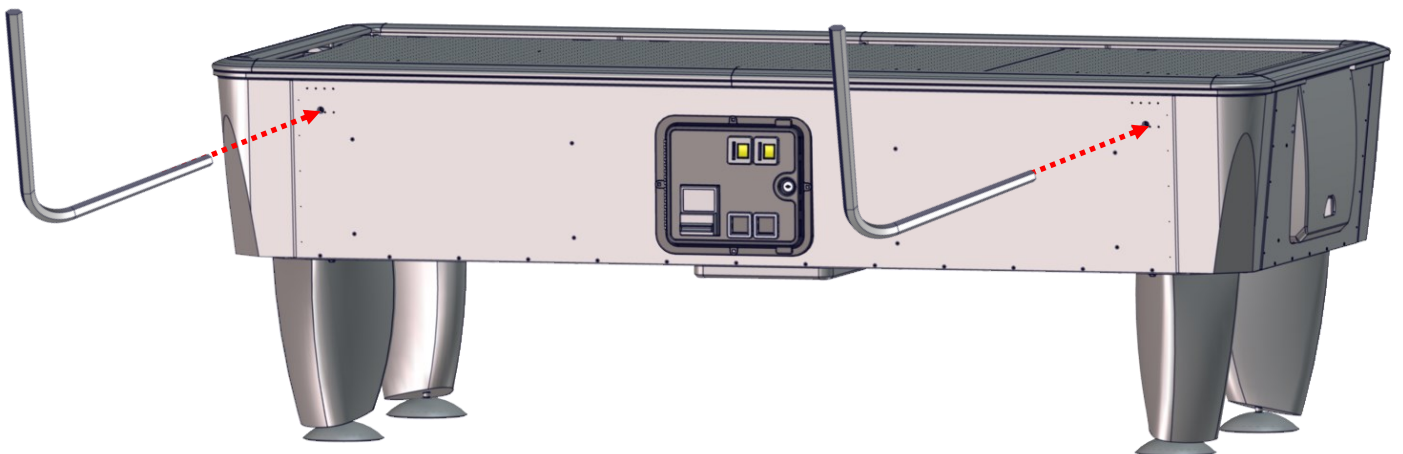

Locating the Score Head and sides:

The score head assembly is bolted to the bottom of the cabinet. The side rails and divider are attached with straps stapled to the bottom of the cabinet.

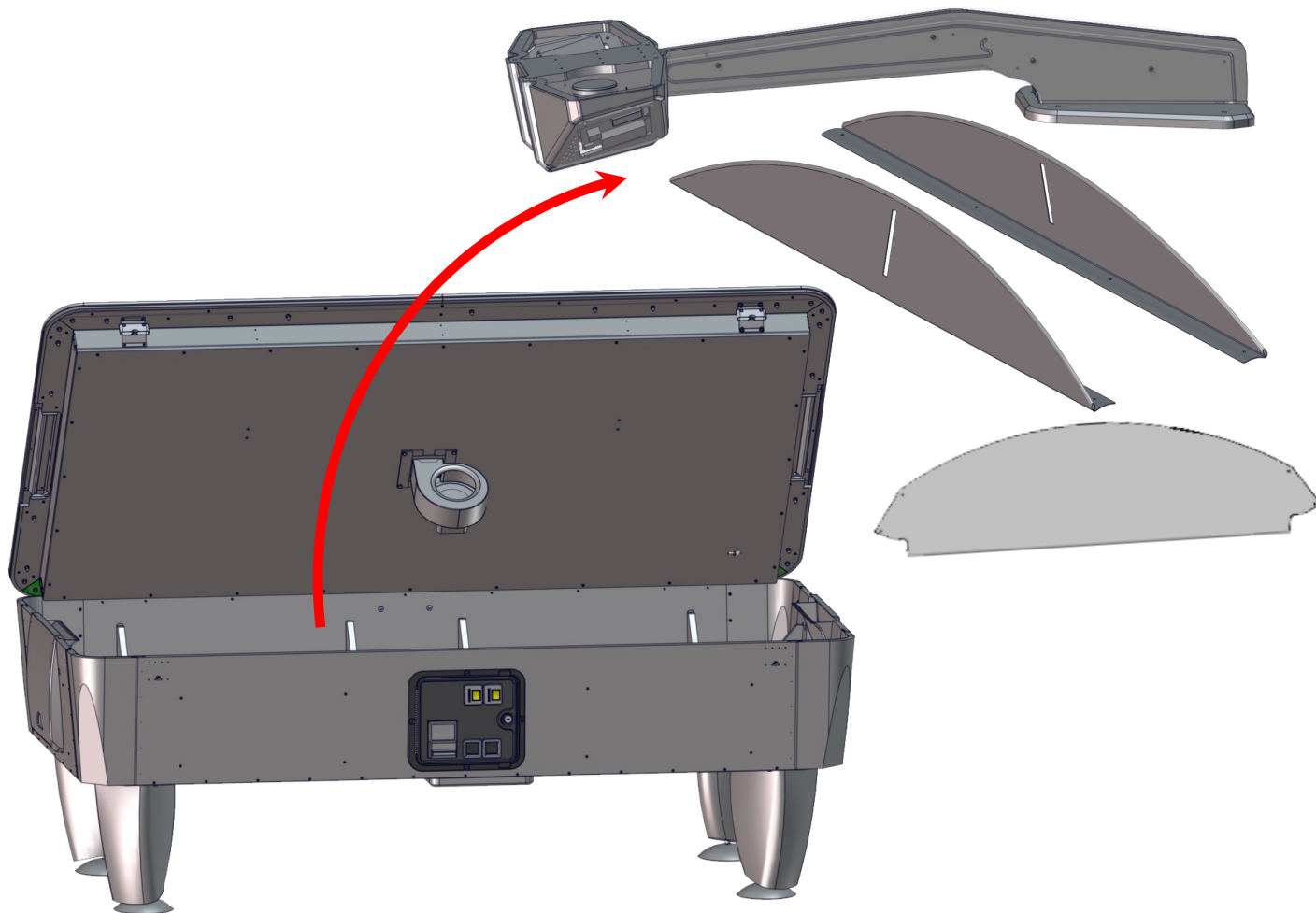

Installing Score Head:

The score head is mounted on the opposite side of the coin door. Insert the wire harness from the score header marquee into the cabinet. Then attach the Score Header Marquee using four AA6584 1/4 20 black bolts and washers. Open the playfield back up and connect the harness.

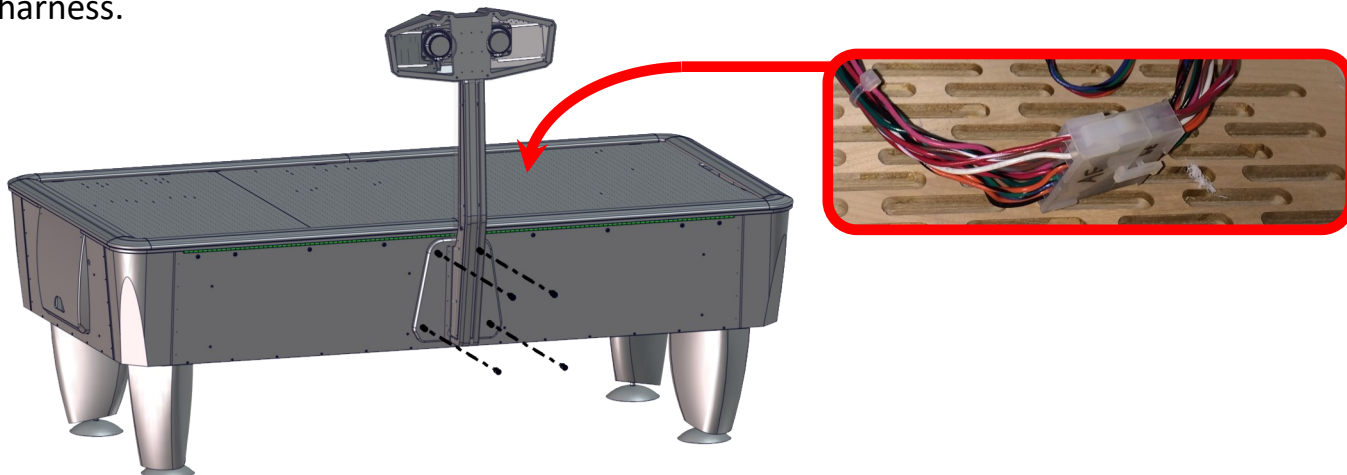

Attaching Side Guards:

Using four AA6032 8x1/2 Hex w/tek screws attach the side guards. Slide the playfield divider into the side guard slot.

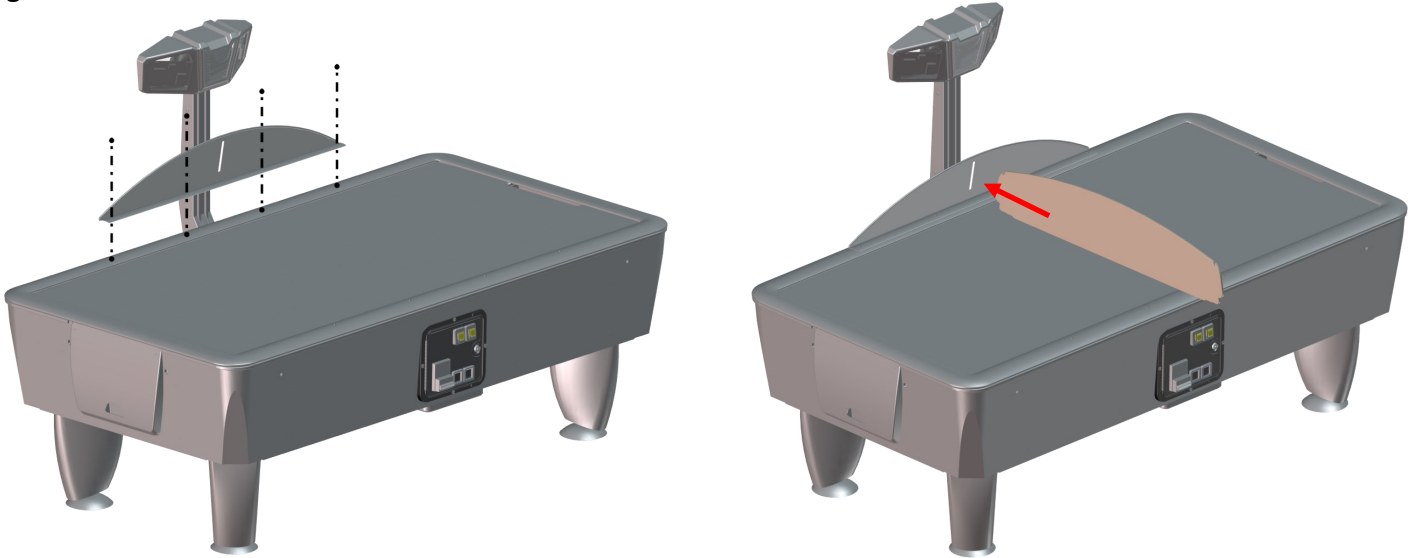

Slide the other side guard into the other end of the playfield divider and attach using AA6032 8x1/2 Hex w/tek screws

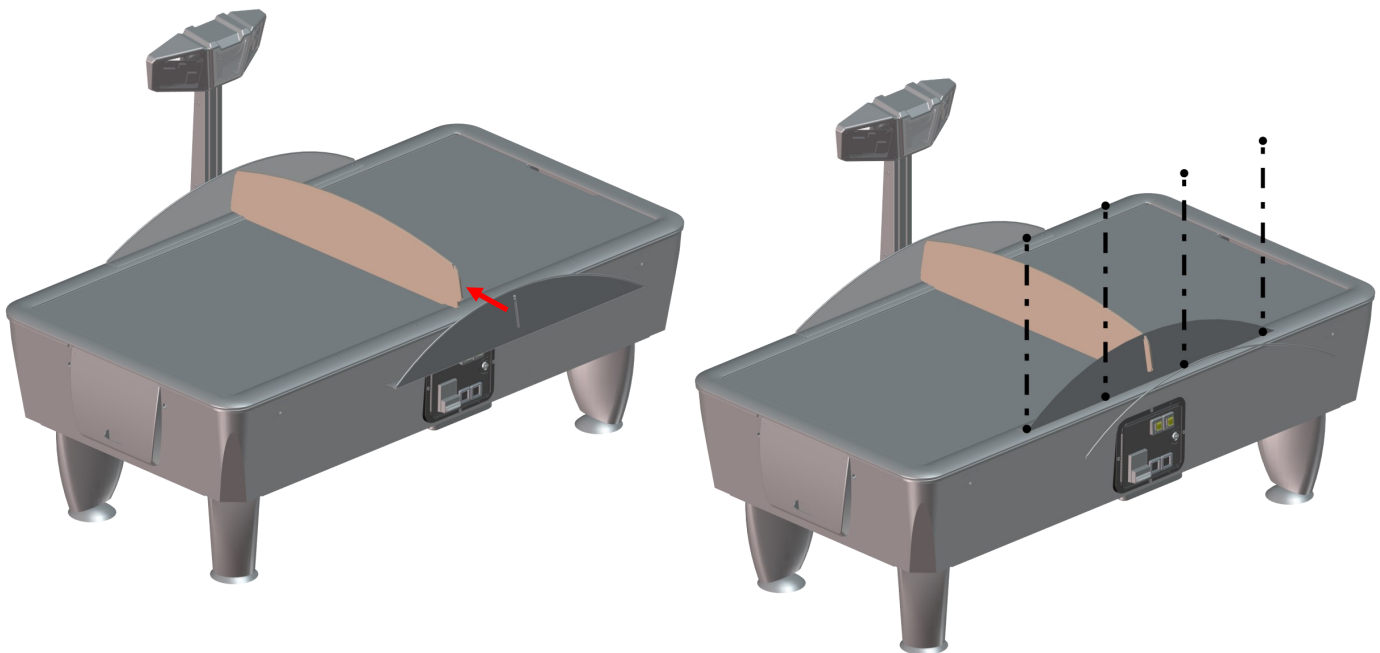

Maintenance Instructions

Only qualified personal should preform any maintenance or repairs on this equipment.

The playing surface should be cleaned once a day with the air motor running for optimum movement of the puck.

Cleaning should be preformed by using soap and water only. No alcohol or ammonia cleaners should be used. Do not use a water jet for cleaning.

This equipment complies with European Regulations EN 60335-1 and EN 60335-2-82

WARNING!

DO NOT use ALCOHOL or AMMONIA based Solvents to clean Acrylic Playfield, or the Surface will crack and break! Failure to follow these instructions will VOID the WARRANTY of the PLAYFIELD.

Included with your new Air FX Air Hockey game is a bottle of high quality Plastic Cleaner. Use this cleaner only to clean your Air Hockey Playfield Surface. Using a soft cotton towel, spray towel (do not spray playfield directly) and gently clean your game a minimum of once a week. It is recommended that you clean the playfield while running, in

Game Mode. The spray is safe and non-toxic. Keeping the playfield clean will ensure the best performance from your game for years to come!



Order Brillianize Cleaner part # AA0057

our website at:

<https://parts.icegame.com/>



Innovative Concepts in Entertainment, Inc

www.icegame.com

Rev B board layout

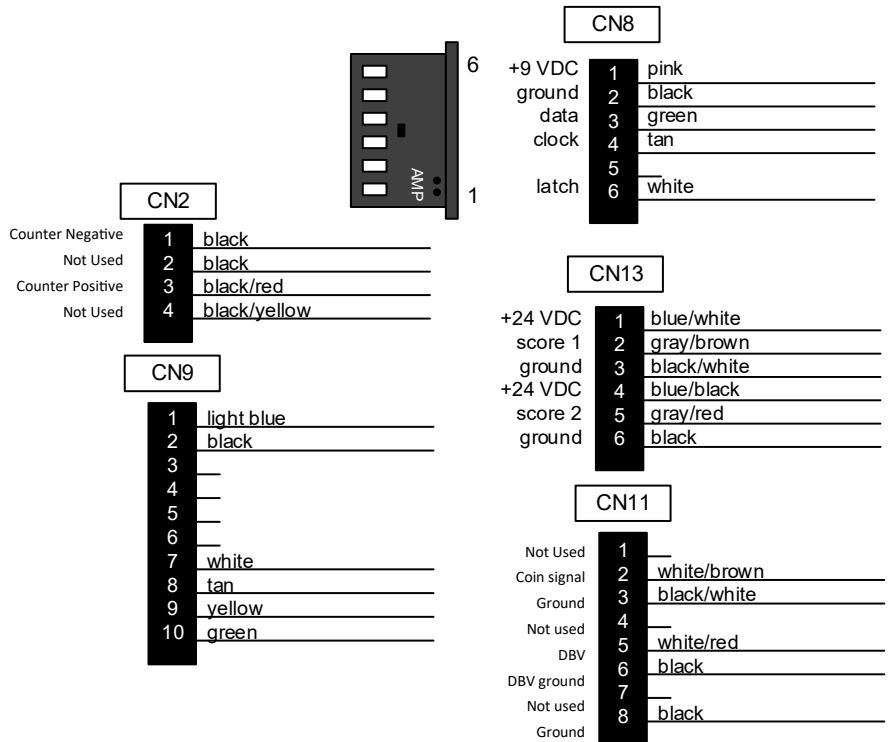
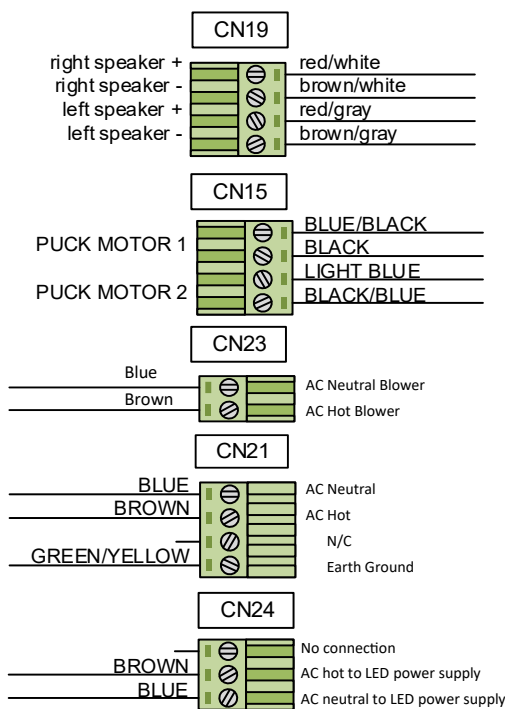
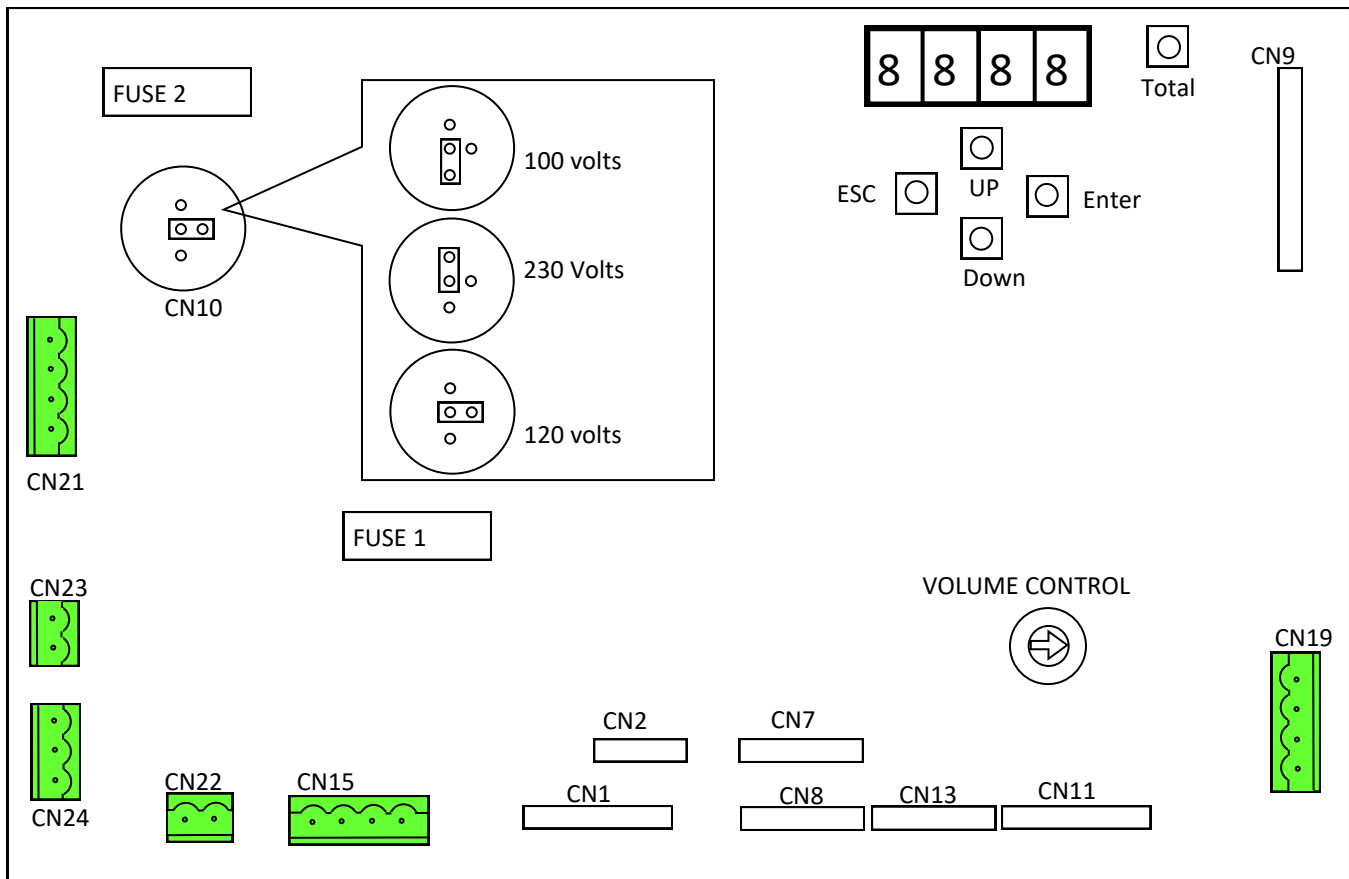

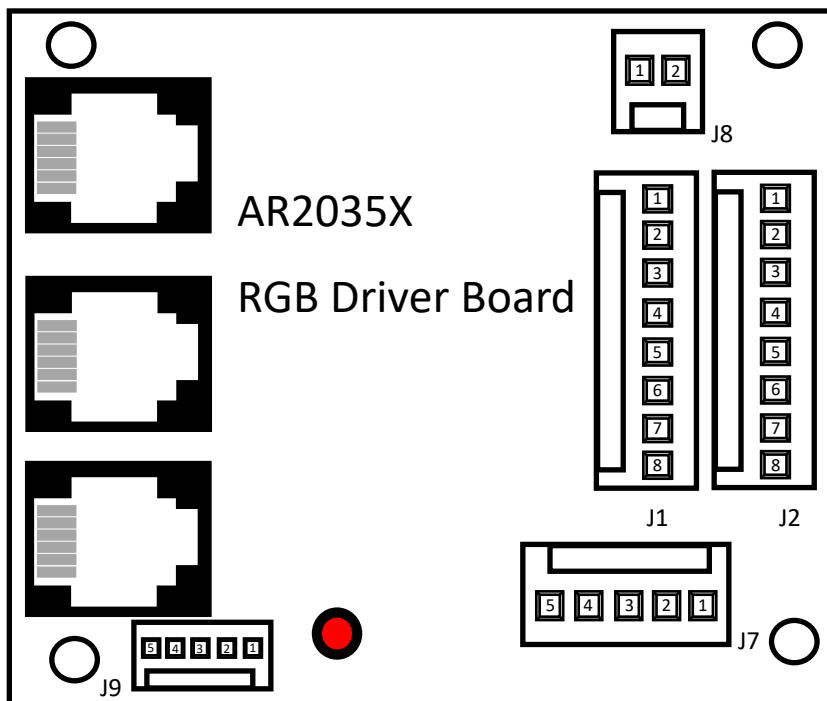

J1: Connector

Pin	Color wire	Description
1	Orange	+12 volts
2	Yellow/red	Red RGB LED
3	Yellow/green	Green RGB LED
4	Yellow/blue	Blue RGB LED
5	Orange/black	Marquee +12 volts
6	Red/Black	Marquee Red RGB LED
7	Green/Black	Marquee Green RGB LED
8	Blue/Black	Marquee Blue RGB LED

J2: Connector

Pin	Color wire	Description
1	Orange	+12 volts
2	Yellow/red	Red RGB LED
3	Yellow/green	Green RGB LED
4	Yellow/blue	Blue RGB LED
5	Orange/black	+12 volts
6	Brown/red	Red RGB LED
7	Brown/green	Green RGB LED
8	Brown/blue	Blue RGB LED

J7:

Pin	Color wire	Description
1	Black	Fused (7amps) +12 volts
2		
3		
4	Black/white	Ground
5	Black/white	Ground

J8:

Pin	Color wire	Description
1	Orange	Marquee +12
2	Black	Marquee ground

Ticket PCB

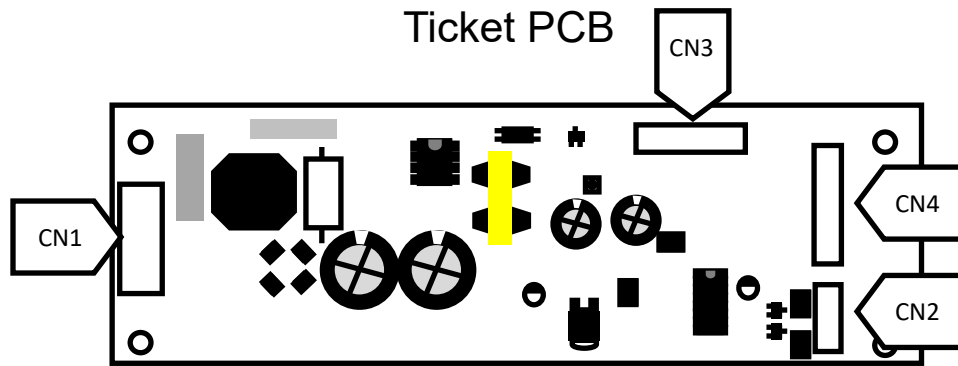

CN4: Connector ; Ticket dispensers

Pin	Color wire	Description
1	Orange	+12 VDC
2	Black	Ground
3	Violet/white	Ticket run line ; Goes High when tickets are owed.
4	Violet/blue	Notch Line ; Goes low when optic is not blocked.
5	Orange	+12 VDC
6	Black	Ground
7	Yellow/white	Ticket run line; Goes High when tickets are owed.
8	Yellow/blue	Notch line ; Goes low when optic is not blocked.

CN1: Connector ; Power

Pin	Color wire	Description
1	Green w/yellow	Earth ground
2	N/A	No connection
3	Blue	Neutral AC
4	Brown	Hot AC

CN3: Connector ; Data to main board

Pin	Color wire	Description
1	light Blue	+24 VDC
2	Black	Ground
3	white	data
4	tan	data
5	yellow	data
6	green	data

Score PCB

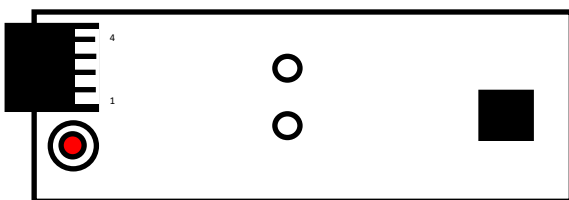

CN1:

Pin	Wire Color	Description
1	Black	Ground
2	Grey/red	Power
3	N/A	No connection
4	Blue/black	Sense

Programming:

To access configuration menu the machine should have no credits and be at attract mode.

To enter the Program Menu press and hold <ENTER> for a few seconds. The display will show "P1". This informs you that you are in program mode.

To navigate the menu:

Momentarily pressing the <ENTER> key will advance to the next parameter.

Momentarily pressing <ESC> key will go back a parameter.

Momentarily pressing <UP> key will INCREASE the value for that parameter.

Momentarily pressing <DOWN> key will DECREASE the value for that parameter.

Holding <ESC> will exit out of the configuration menu and SAVE CHANGES.

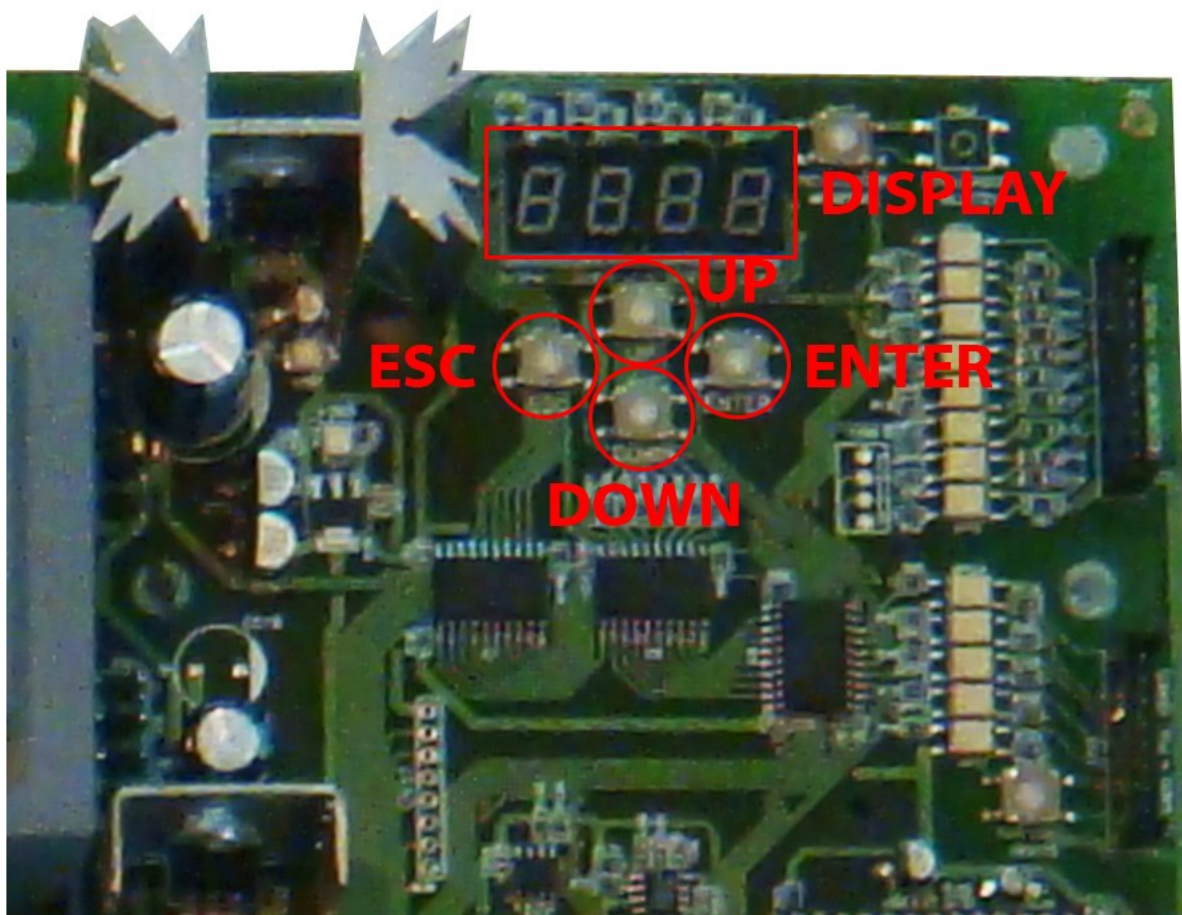

Version 1.09

P1 (goals): Maximum number of goals per game: [7]

Minimum value 2.- Maximum value 9.

P2 (time): Maximum length of the game (in minutes): [5]

Minimum value 2.- Maximum value 9.

P3 (free games): Length of the free games mode (in hours): [1]

Minimum value 1.- Maximum value 9.

P4 (small coin): Number of small coins per 1 pulse: [1]

example: 2 small coins for 1 pulse.

Minimum value 1.- Maximum value 99.

P5 (big coin): Number of big coins for 1 pulse: [1]

example: 2 big coins per 1 pulse.

Minimum value 1.- Maximum value 99.

P6 (small coin): Number of games per 1 pulse: [1]

example: 1 game per 1 pulse SO: 2 small coins coins= 1 game.

Minimum value 1.- Maximum value 9.

P7 (big coin): Number of games per 1 pulse: [1]

example: 3 games per 1 pulse SO: 2 big coins= 3 games.

Minimum value 1.- Maximum value 9.

P8 (small coin): Number of small coins per 1 small bonus: [0]

example: 4 small coins for 1 small bonus.

Minimum value 0.- Maximum value 99. Value 0 no small bonus.

Programming continued

P9 (big coin): Number of big coins per 1 big bonus: [0]

example: 2 big coins for 1 big bonus.

Minimum value 0.- Maximum value 99. Value 0 no big bonus.

P.0 (small coin): Number of games per 1 small bonus: [1]

example: 1 game per 1 small bonus.

Minimum value 1.- Maximum value 8.

P.1 (big coin): Number of games per 1 big bonus: [1]

example: 1 game per 1 big bonus.

Minimum value 1.- Maximum value 8.

P.2 (tune): Select tune during the game: [2]

Minimum value 1 (for BABY air hockey).

Maximum value 2 (other models: 2 random tunes).

P.3 (tune): Appeal tune activation: [1]

Minimum value 0 (not activated).- Maximum value 1 (activated).

Programming continued

T1 (ticket): Number of ticket dispensers connected:

Minimum value 0.- Maximum value 2. [0]

T2 (ticket): Number of tickets per scored goal: [1]

Minimum value 0.- Maximum value 9.

T3 (ticket): When tickets per goal are delivered: [1]

Minimum value 1 (when goal is scored).

Maximum value 2 (at the end of the game).

T4 (ticket): Number of tickets per won game: [0]

Minimum value 0.- Maximum value 9.

T5 (ticket): Display tickets counter in collection

sequence (only ifT1 =2): [0]

Minimum value 0.- Maximum value 2.

Modes:

Value 0: small coin- big coin- ticket1 - ticket2

Value 1: small coin- big coin- tickets

Value 2: small coin- big coin- ticket1 - ticket2- tickets

E1 (operating): Special function mode: [0]

DOOR MOTORS ALWAYS CLOSED:

GOAL OPEN JUST WHEN GOAL SCORED.

Minimum value 0 (normal function mode).

Maximum value 1 (special function mode)

Ball Deflector Mounting Positions

** NOTE ** Color has been changed to red to accent.

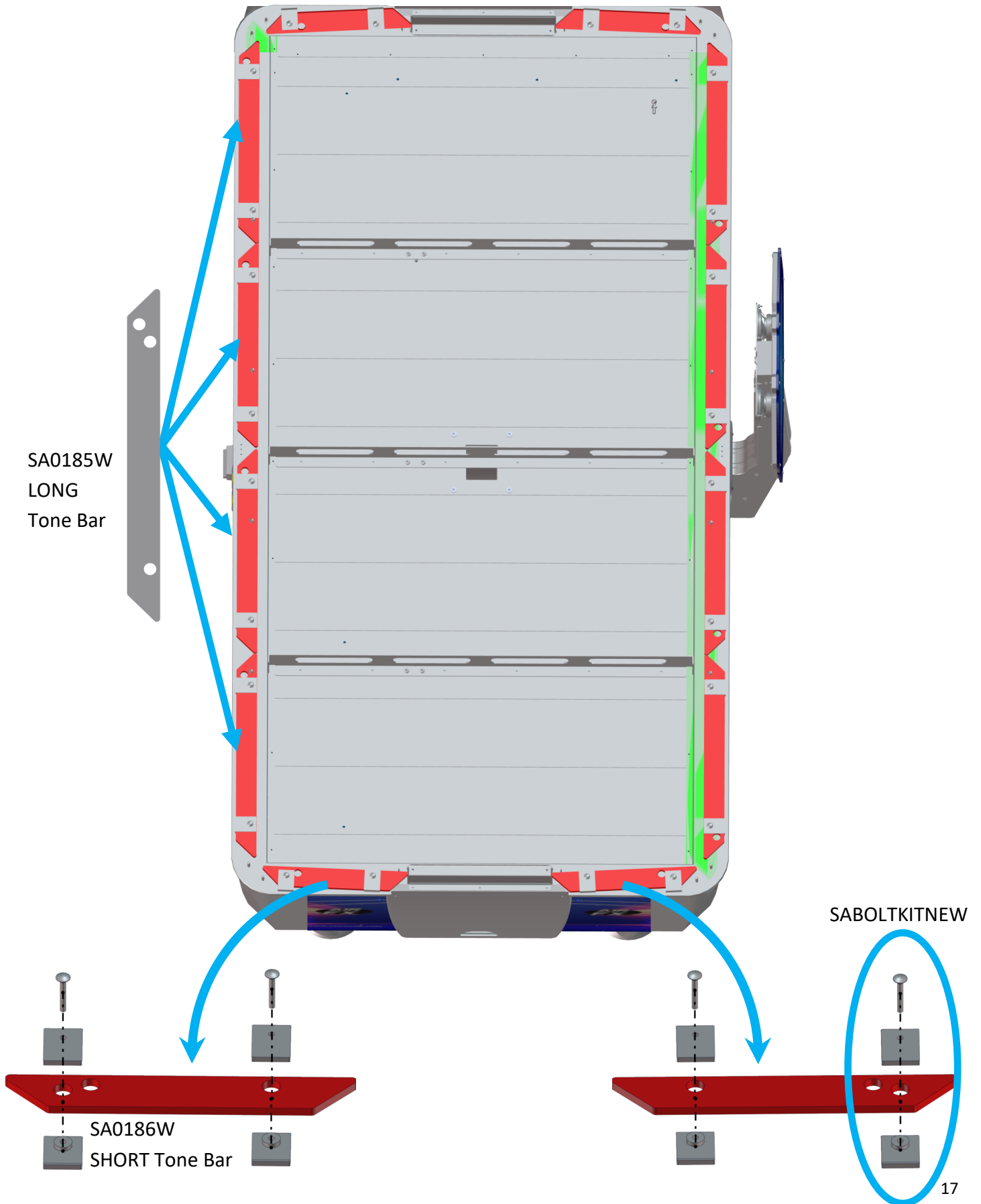

Accessing the SA1228 Boards

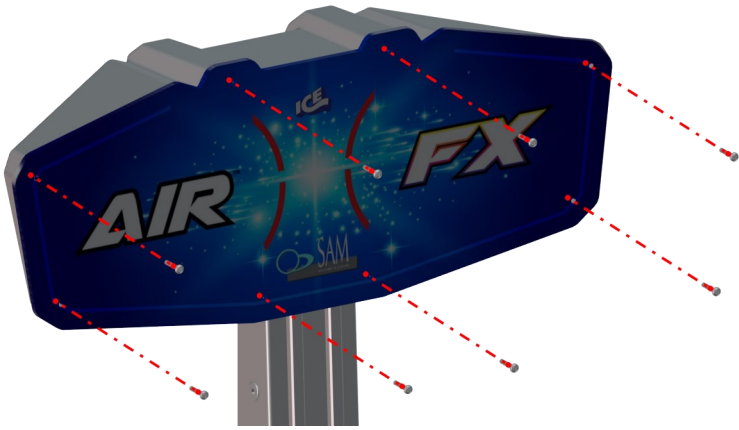

Step 1: Remove the back cover.

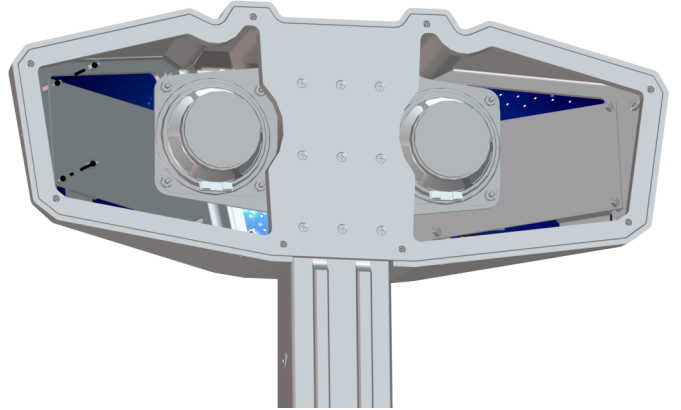

Step 2: Remove the standoffs that hold the boards .

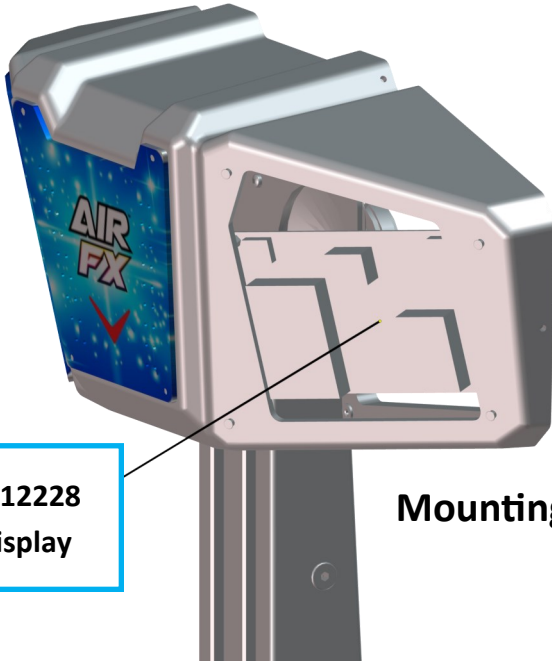

SA12228
Display

Mounting position determines dipswitch settings.

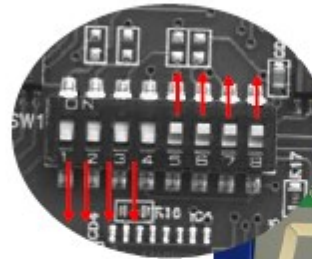

RIGHT DISPLAY
SA12230

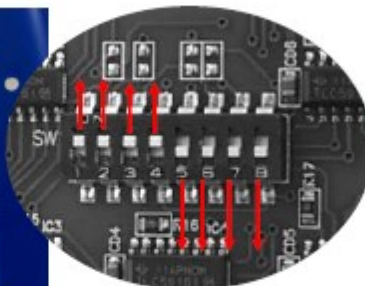
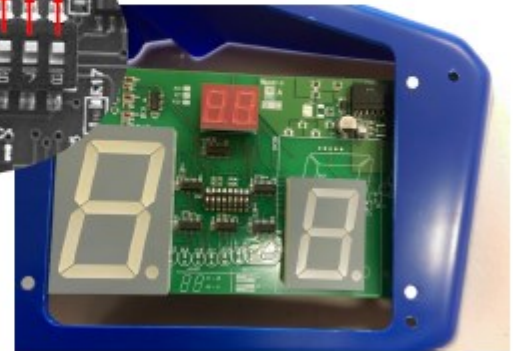

LEFT DISPLAY
SA12230

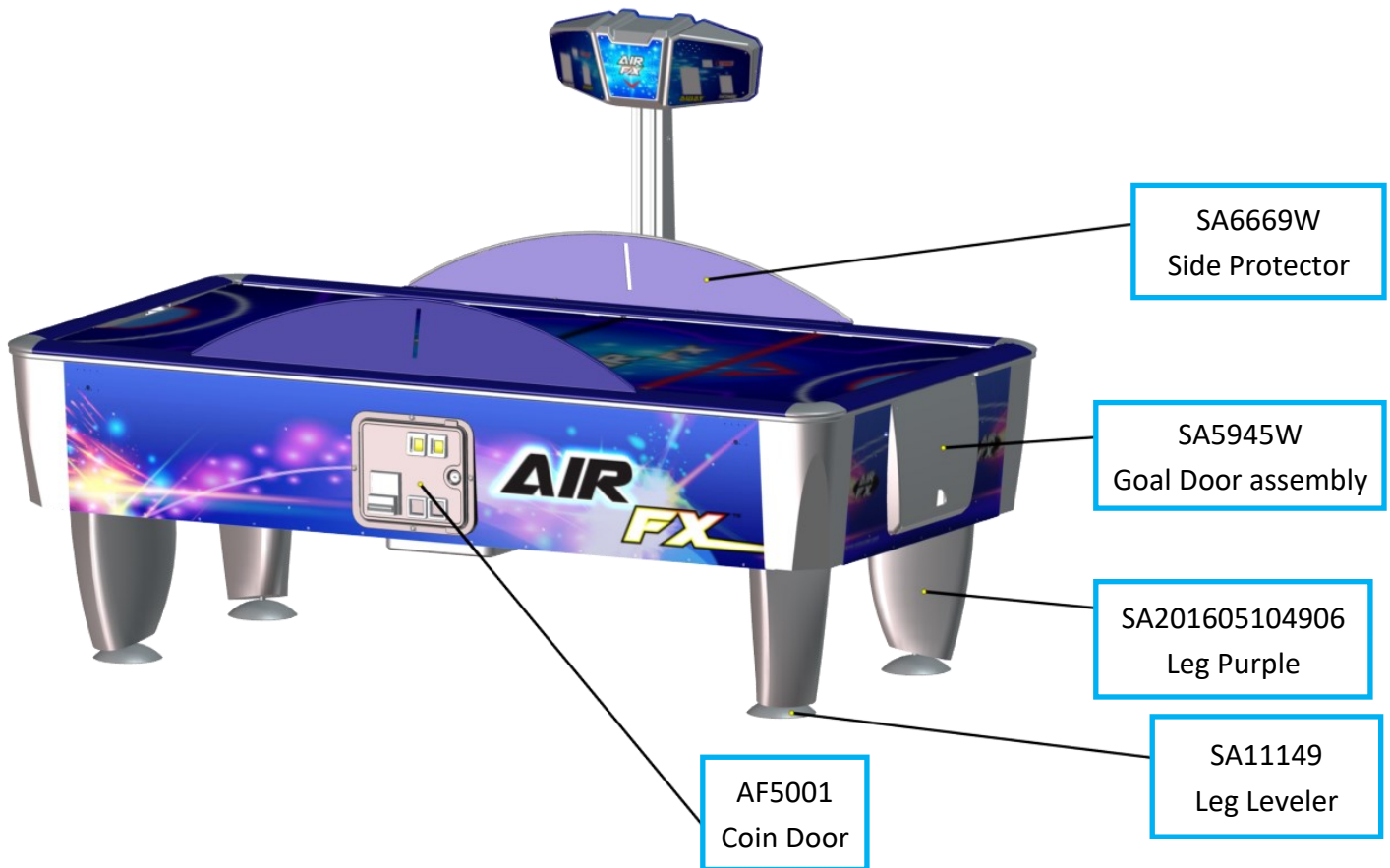
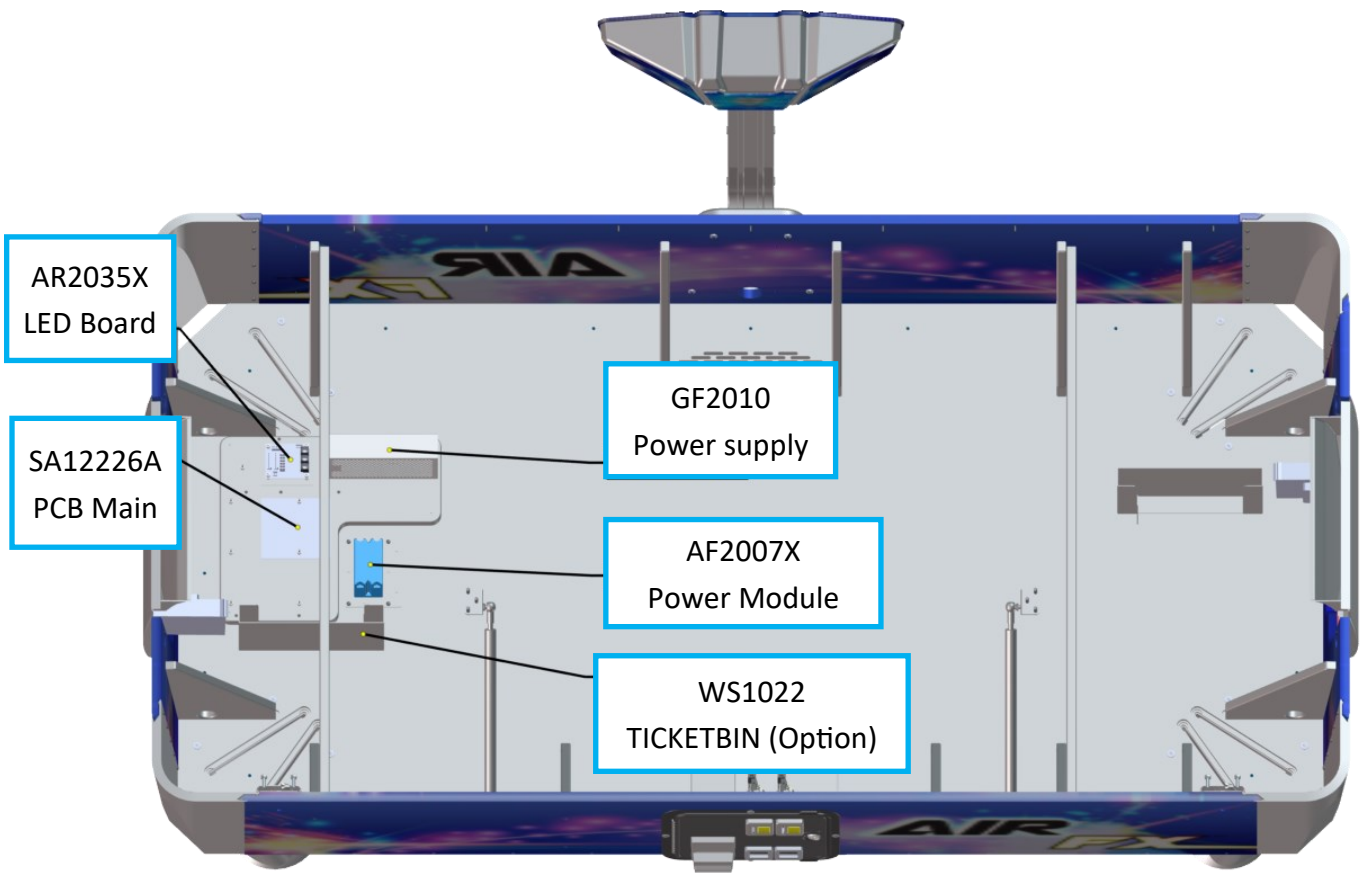

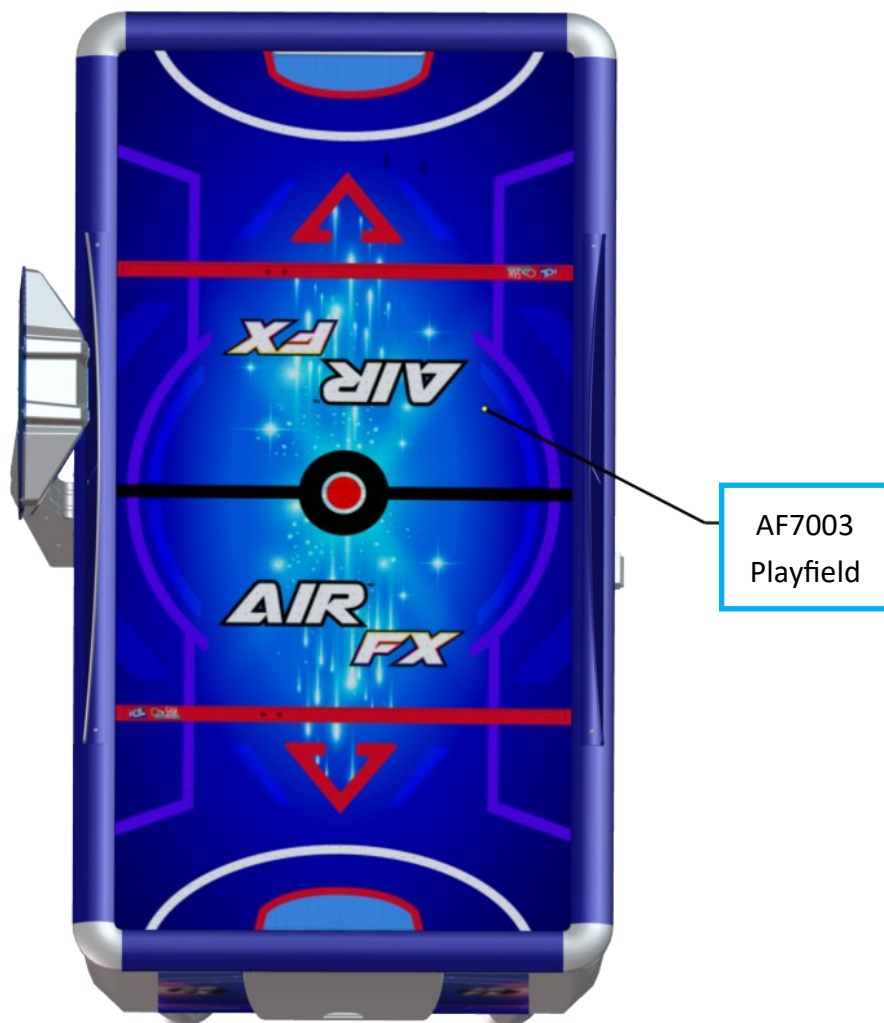
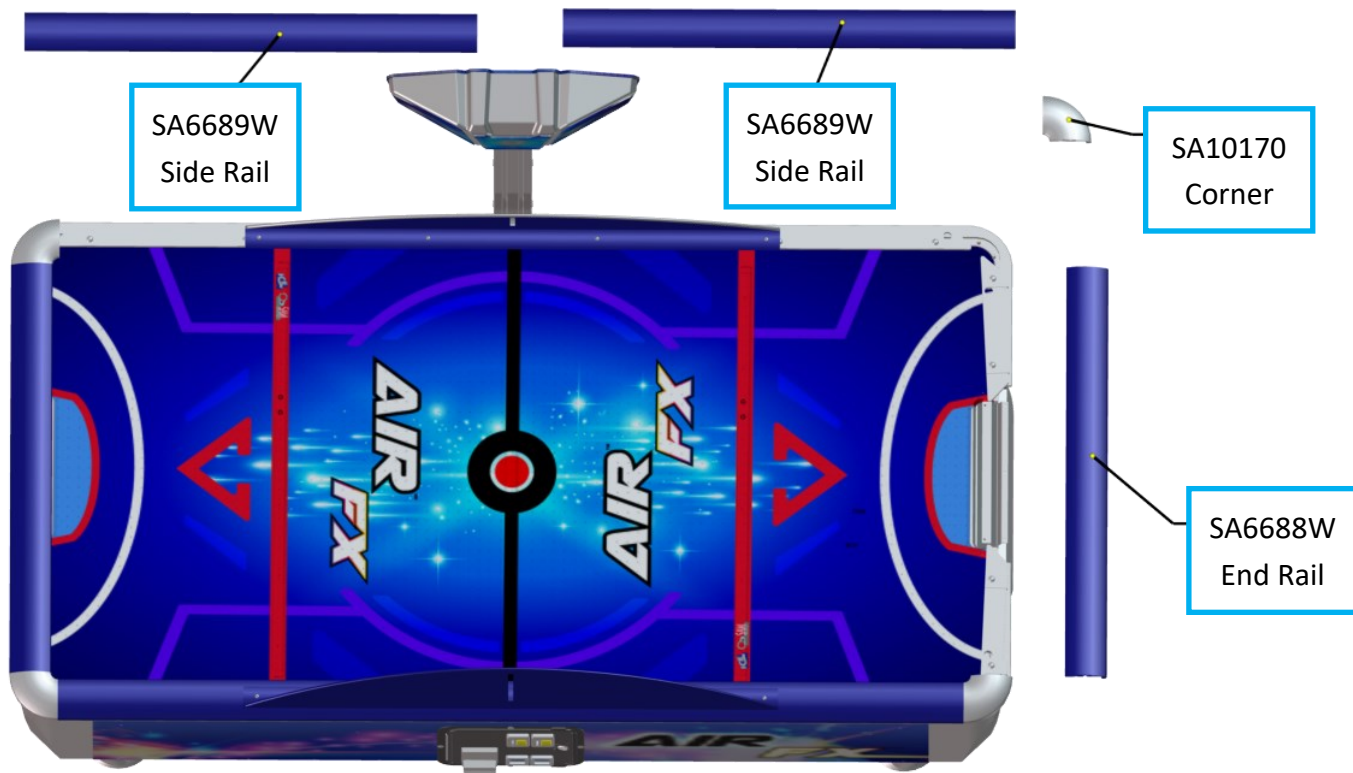

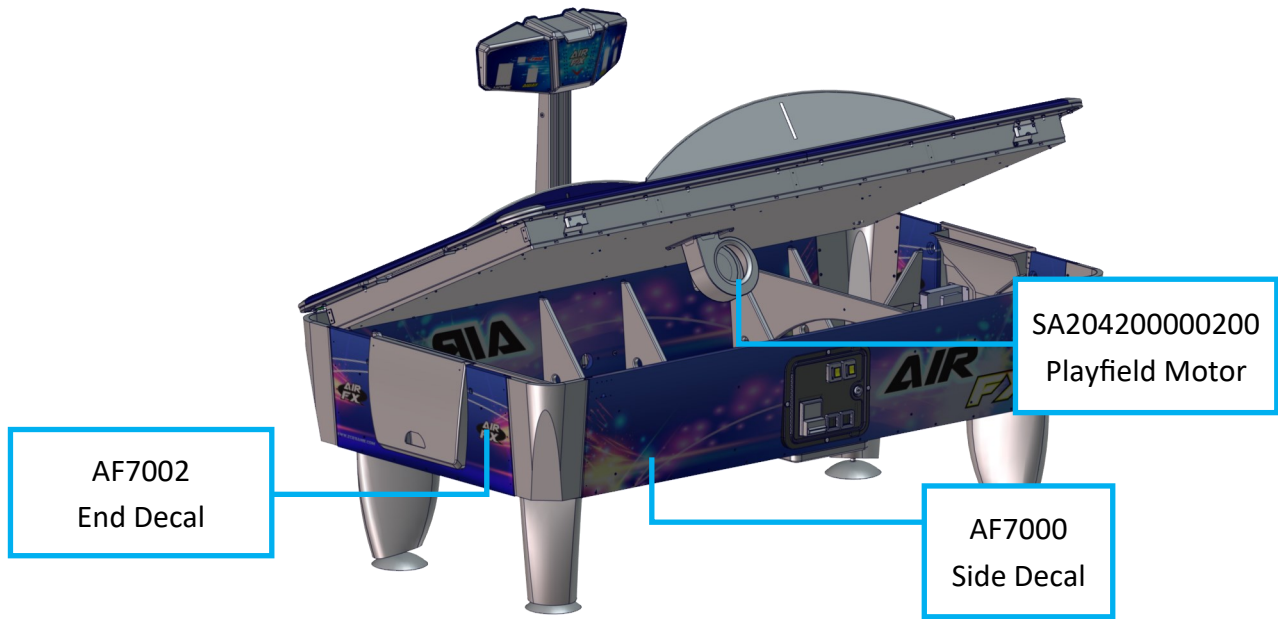

Spare Parts List

ICE part	Description
SA0259	Bright Yellow (hard/fast) puck
SA1006RF	Player handle red
SA1007BF	Player handle blue
E00724AFAX	LED strip RGB 59 cuts
E00724AFBX	LED strip dual 4 cuts
E00852AFX	LED strip large white 19 cuts
AA5014	7/8 cam lock
SA0258	Puck Blue
SA11766	Cash Box
SA12344	Puck Motor
SA12220	Goal Sensor



WARRANTY POLICY

ICE Inc. warrants that all of its products will be free from defects in material and workmanship. When placing a warranty request, please be prepared to provide the following information:

- Serial Number of Game or Bill of Sale
- Machine Type
- A Detailed Description of the Equipment Fault Symptoms

ICE product, including, Sam's Billiards, Neolith, Game Concepts & Funway is warranted as follows:

- 180 days on the Main PCB, Computers and Motors
- 1 Year on LCD/LED Monitor Panels (through Manufacturer)
- 90 days on all other electronic/mechanical components (i.e. DBV's, Ticket Dispensers)
- 30 days on all parts and repaired items
- ICE Inc shall not be obligated to furnish a warranty request under the following conditions:
- Equipment has been subjected to unwarranted stress through abuse or neglect
- Equipment has been damaged as a result of arbitrary repair/modification attempts
- Equipment that has failed through normal wear and tear (bulbs, balls, buttons, etc.)

ICE Inc. will assume no liability whatsoever for costs associated with labor to replace defective parts or travel time associated therein.

All defective warranty covered components will be replaced with new or factory refurbished components equal to OEM specifications. ICE Inc. (or the manufacturer) will cover domestic (U.S.A.) UPS ground (or comparable shipping means) freight costs to the customer during the warranty period. Expedited shipments are available for an additional charge at the customer's own expense.

Defective parts are to be returned to ICE Inc. (or the manufacturer), at the customer's expense, in a timely fashion. They should be packaged following UPS guidelines to insure safe transit back to ICE. Adequate value freight insurance should be used in case the shipper damages the item and a claim must be filed.

ICE distributors are independent, privately owned and operated. In their judgment, they may sell parts and/or accessories other than those manufactured by ICE Inc. We cannot be responsible for the quality, suitability or safety of any non-ICE part, modification (including labor) that is performed by such a distributor.

Innovative Concepts in Entertainment

10123 Main St.

Clarence, NY 14031

Phone #: (716) - 759 – 0360

Fax #: (716) – 759 – 0884

www.icegame.com